

# *AUTOMATIC* WRAPPER



**DO<sub>2</sub> RAPID WRAPPER**



LOOK AT THE VIDEO!

Patented 2262688, 590 292, 2.676.242, 2.694.831, 8.534.033, 6.460.314

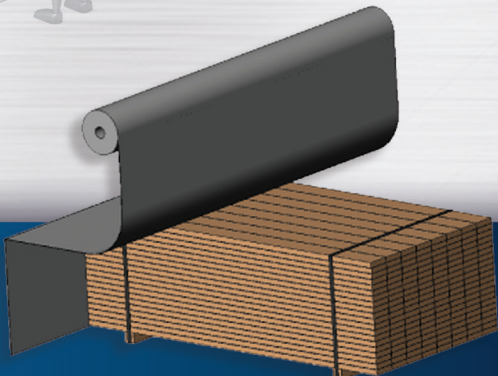

***THE WRAPPING LEADER!***

# S-30 WRAPPER / S-60 WRAPPER

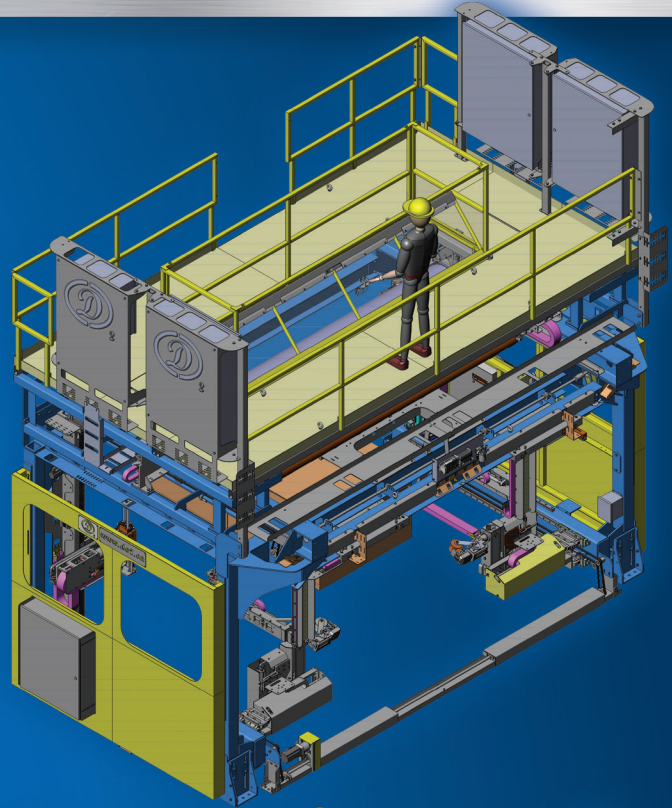
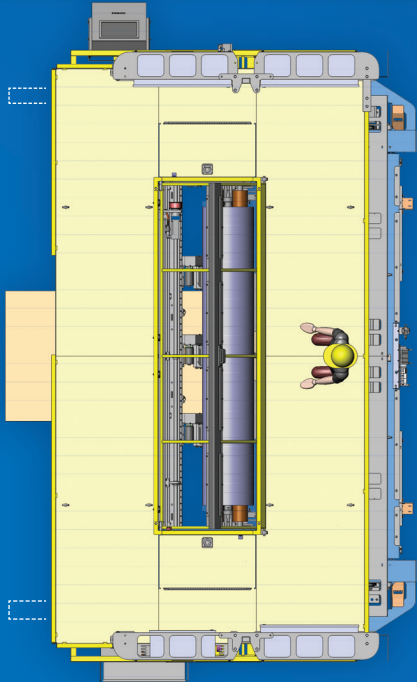

66"  
(1 670 mm)

66"  
(1 670 mm)

39" (990 mm) +  
Package height  
x2

Transfer height  
27" (823 mm)

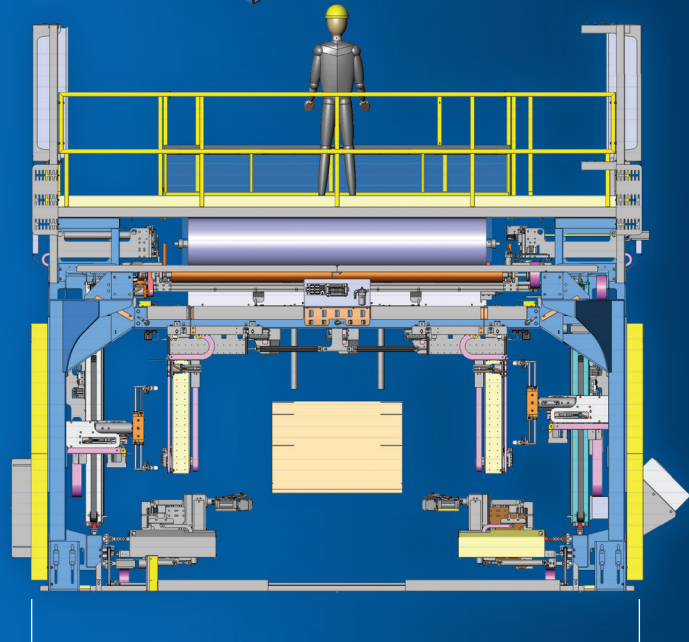

S-30 10' (3050 mm)

Longest bundle  
7' (2 130 mm)

18'-7" (5 660 mm) - Bundle height : 33" (840 mm) and lower  
21'-3" (6 480 mm) - Bundle height : 43" (1 090 mm) and lower

## SPECIFICATIONS

- 2 stop positions
- Standard dispenser
- Limitless number of dispenser
- Upgradable number of dispenser in frame
- 400-460V/40A
- 36 CFM@90 PSI (1000lpm@ 0,6 MPa)
- Shortest package 5'
- Longest package no limit
- S-30 + secondary staplers = S-60

# S-90 WRAPPER

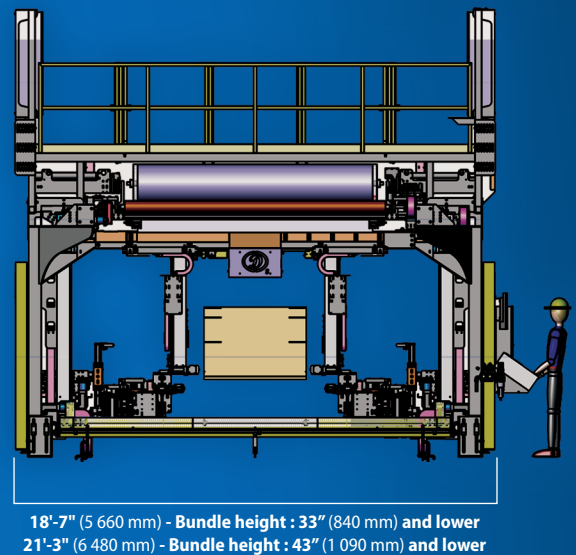
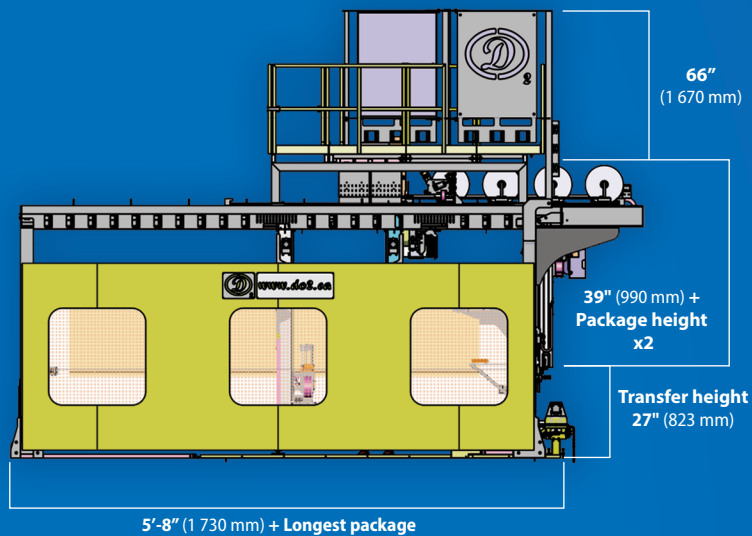
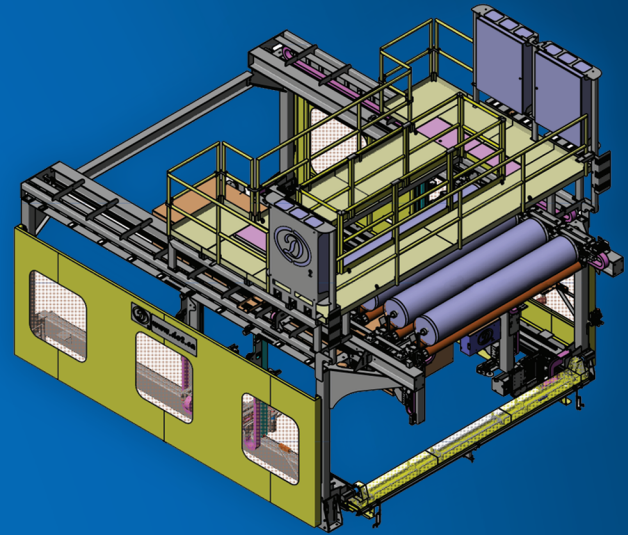
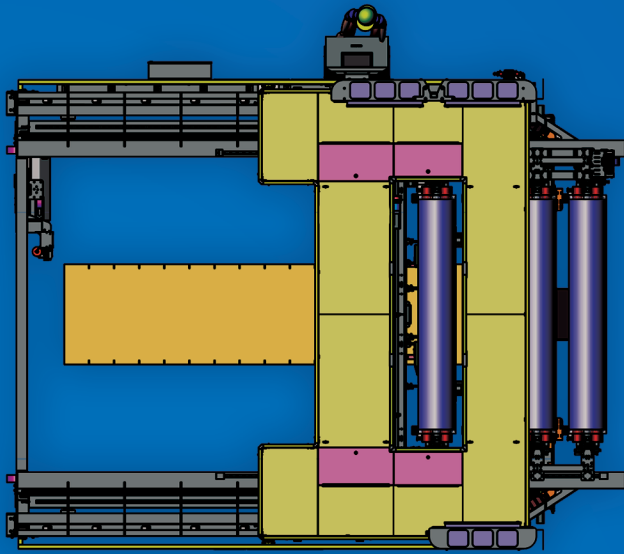

## SPECIFICATIONS

- 1 stop position
- Standard dispenser
- Limitless number of dispenser
- Upgradable number of dispenser in frame
- 400-460V/60A
- 50 CFM@90 PSI (1400 Imp@ 0.6 MPa)
- Shortest package 5'
- Longest package 26'

# SECONDARY STAPLERS : LINEAR OR ROTARY

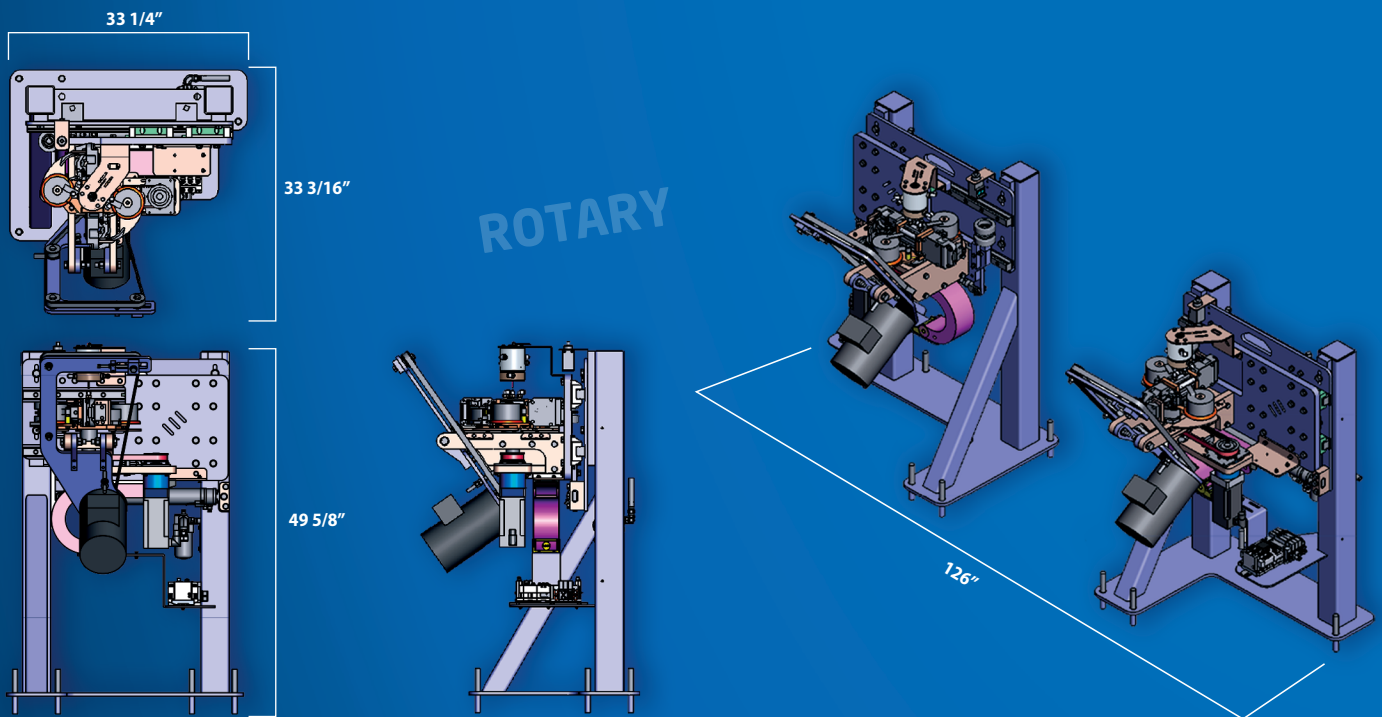
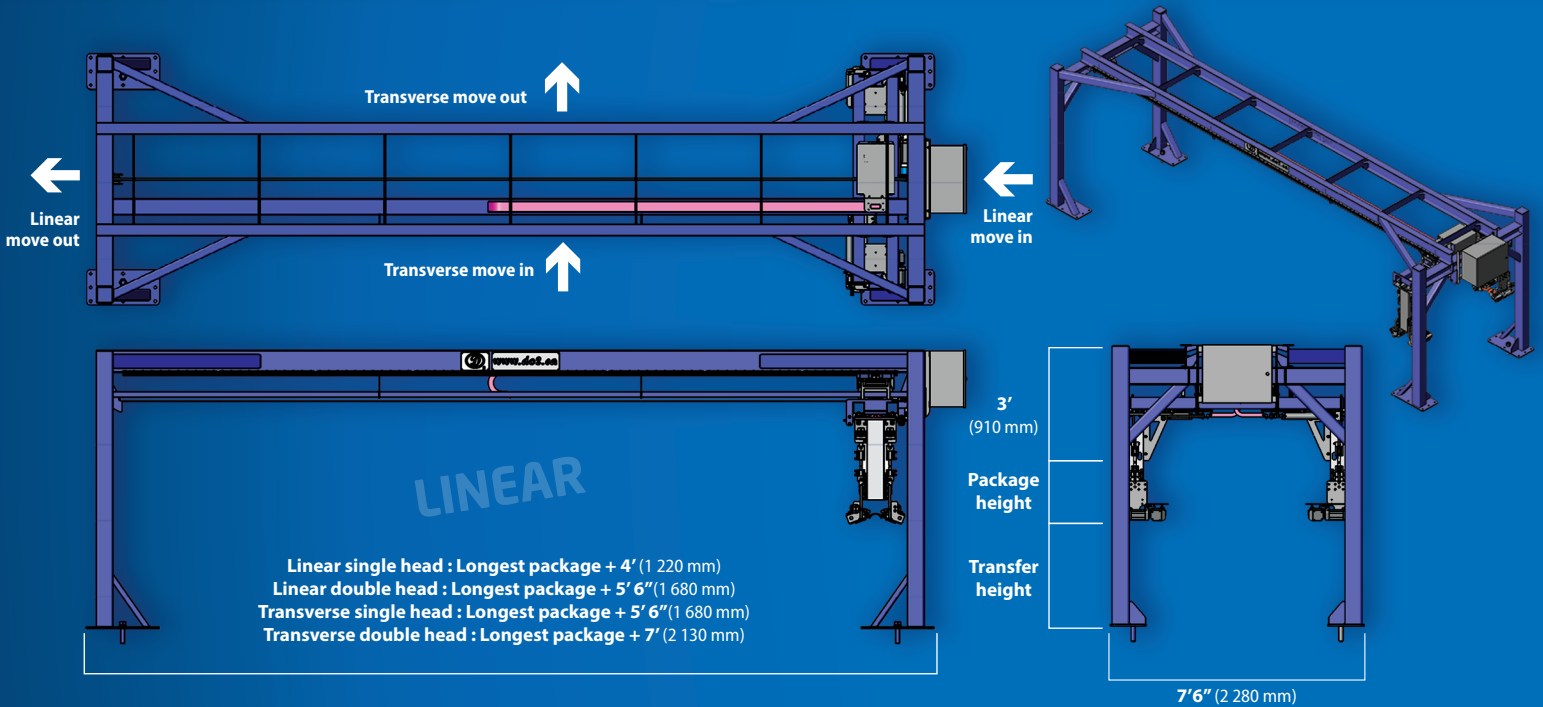

## SPECIFICATIONS LINEAR

- Dual head approx. 40% faster
- Infeed linear or transverse
- Outfeed linear or transverse
- At min of (longest pack - 7') from S-60 frame
- At min of 0' from S-90 frame
- 1 stop position
- Operator console
- Independent lock out zone

## SPECIFICATIONS ROTARY

- Wrap tensioning
- Operator console
- Moving stapling up to 80 FPM

# PATENTED AUTOMATIC WRAPPER

Prints label  
directly on wrap



Prints label  
directly on wood

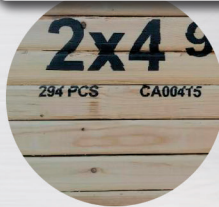

Staple applied  
confirmation,  
coiled stapling

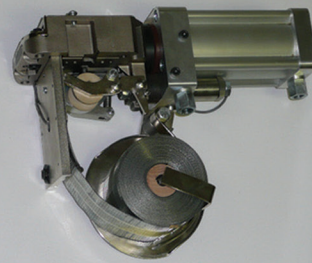

Patented label printer



Operator free



Wrap : up to 4 500 linear feet roll (1 370 m)\*

\* 18 1/2" (450 mm) diameter max.

Staples : 5 000 per coil



[www.do2.ca](http://www.do2.ca)

DO<sub>2</sub> RAPID WRAPPER

## Benefits

- Operator free
- Consistent wrapping quality
- Fast wrapping
- Fast payback
- Low maintenance
- Reliable
- Safe
- Low cost labeling with great quality
- User friendly
- Uses standard woven wrap
- High autonomy
- Less staples
- Consistent staples positions
- Less waste
- Machine safety ready



## Technical support

- VPN Access for remote assistance (controlled by the mill)
- Camera for remote assistance
- Parts catalog
- Mechanical, electrical and operator training guide
- 24/7 line
- Integrated diagnostic tools

## Zero maintenance components

- Gearbox Alpha zero backlash
- Timing belts
- Self lubricated NSK linear bearing
- SMC pneumatic components

## Customer provided

- VPN Access
- Internet access

## Electrical parts

- HMI 15" (380 mm)
- Allen Bradley servo-motors
- Drive Kinetix Ethernet IP
- Control Logix PLC
- SMC Ethernet IP manifold
- Factory talk view
- RS logix
- DO2 printing software

## Alarm

- Automated alarm system ( Paget, SMS, E-mail, HMI )
- Yellow alarm, the wrapper still works but warns you about a low level on a consumable
- Red alarm, the wrapper needs an intervention or a fill up on a consumable
- Low air pressure alarm

## Autonomy

- Paper roll, 340 bundles
- Staples coil, 500 bundles per coil
- Printer, 660 bundles

## Available options

- Lath breaker/centering
- Wrap lifting tool
- Safety walls
- Hand rails/stairs
- Turn key install
- Transfers/rollcases
- Outfeed program and integration
- Maintenance plan/support line
- Tracking system with camera
- Over head monorail to reload wrap
- Wrap storage platform
- Custom request



# FOLLOW THEIR LEAD!





# THE WRAPPING LEADER! DO<sub>2</sub> Rapid Wrapper



-  Operator free
-  Label directly on wrap
-  High Autonomy

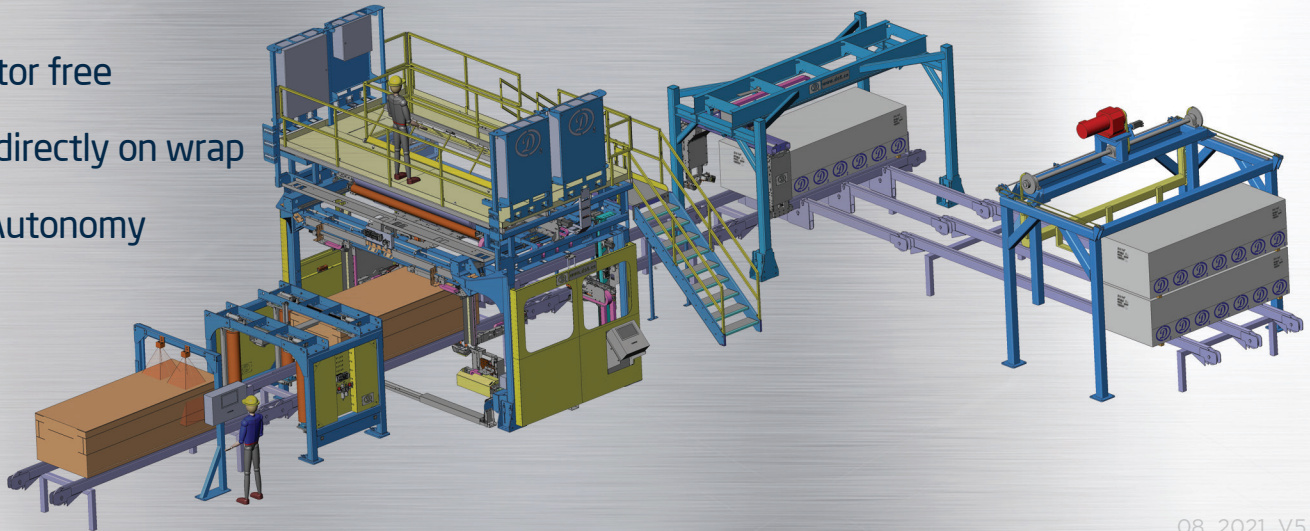

08\_2021\_V5

[www.do2.ca](http://www.do2.ca) • 1 888 276-0554

## DO<sub>2</sub> Industriel

303, 8<sup>e</sup> Avenue  
Dolbeau-Mistassini (Québec) G8L 1Z6

Phone : 418 276-0555  
Fax : 418 276-0653

Patrick Sasseville, engineer, project manager 418 637-8334  
Stéphane Tremblay, general director 418 671-9802  
Frank Bernard, engineer, technical director 418 671-9702  
Sylvain Minier, technical director 418 671-8802  
Martin Perreault, R&D director 418 671-9902

## DO<sub>2</sub> Contrôle

501, Rue J. Adélarde Gagnon  
Dolbeau-Mistassini (Québec) G8L 0B1

Phone : 418 276-9992  
Fax : 418 276-9996

Mario Gauvin, engineer, general director 418 515-0089  
Francis Lepage, engineer, project manager 418 637-5377  
Michel Painchaud, engineer, project manager 418 515-1450