

CENSOR plastics recycling

Setting standards



CENSOR

Technology that pays off

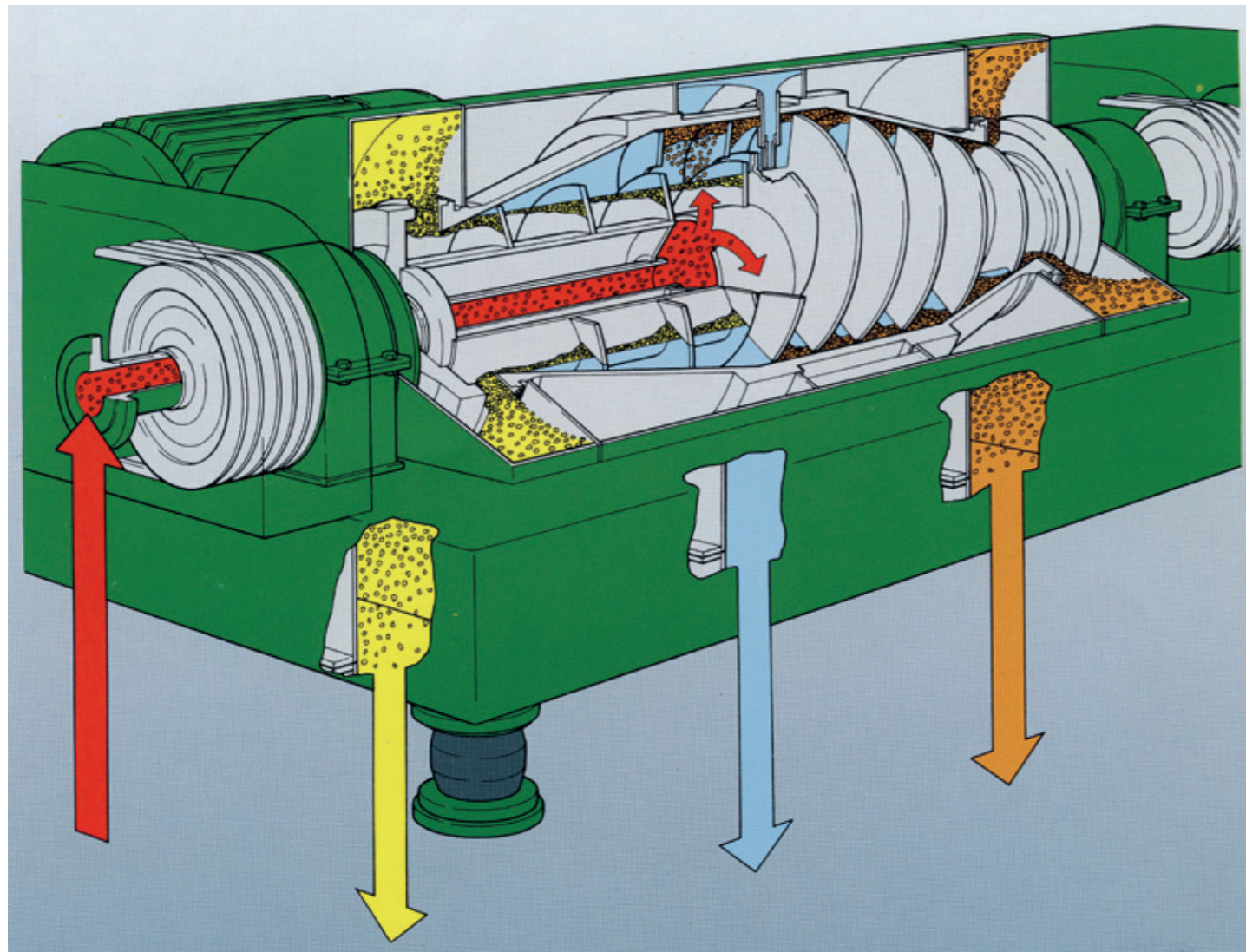

The most advanced separation technology for all applications

Plastics recycling has become much more specialized. The recycling aspects are being included more and more in the conception of new products. New, improved technologies have been developed in response to current concerns about the recycling of products at the end of their lifetime. These technologies now include the recycling of post-consumer carpets.

New applications have emerged for recycled plastics in all areas of plastics processing, such as film or profile extrusion, blow molding, and injection molding. However, the most important requirement in plastics recycling is product quality. Reliable specifications for MFI, specific density, modulus of elasticity, color, and so on must be provided to verify quality to potential customers.

Only pellets that meets these stringent demands will have a chance on the market in the long term. ANDRITZ centrifuge technology offers the means of meeting these high standards. It ensures constant outstanding quality of the regranulate.

Special features of plastics separation with the CENSOR process

ANDRITZ has developed a plastic sorting method that is characterized by high-performance separation, which is particularly suitable if the products have to be of high purity and whenever the waste plastic mix contains different shapes and sizes of particles.

Applications

- Post-consumer waste
- Industrial waste
- Production waste
- Technical plastics
- Films
- Bottles
- Carpets
- Fibers
- Plastics from the automotive industry

Benefits

Economical

- low fresh water requirement
- low space requirement
- simple operation
- low energy demand
- high availability

Process

- high selectivity
- clean products
- little loss of valuable materials

Ecological

- minimal waste water discharge
- high selectivity means maximum recovery

Technologically advanced

- proven modern machine technology
- ANDRITZ centrifuges of modular construction, manufactured in series

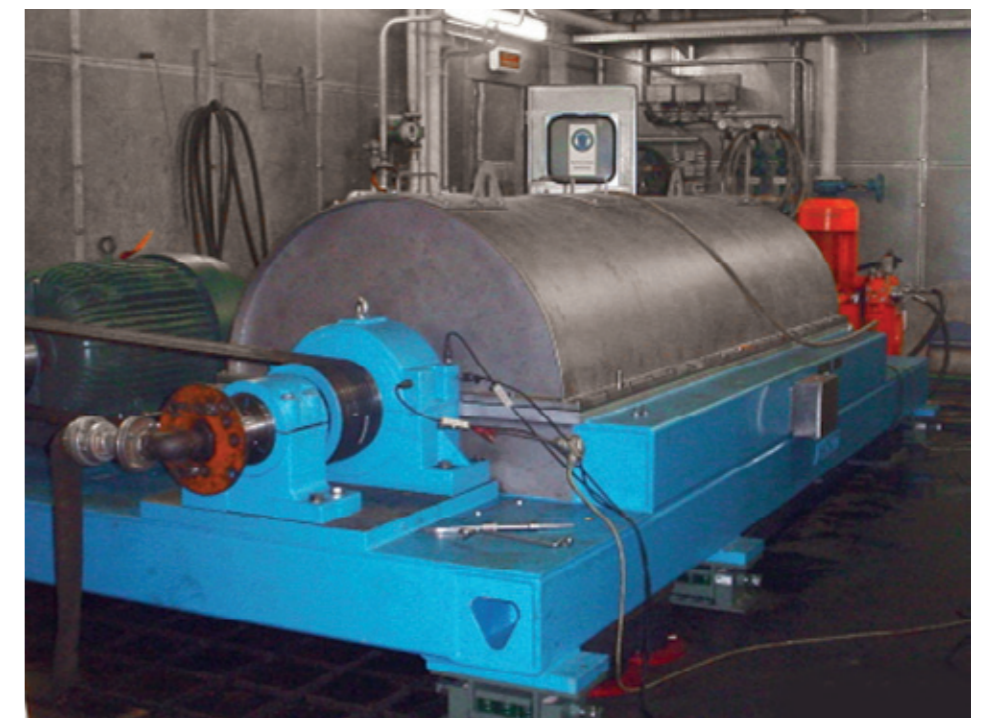

CENSOR sorting for a standard feed rate of 4,400 lbs/h ▶

CENSOR

The principle

The core unit of the process is the sorting centrifuge, which separates, washes, and dewateres the products simultaneously.

The operating principle is shown in the schematic diagram. The commingled plastics, which are normally pressed in bales when they arrive at the recycler site, are reduced to a particle size of 15 mm, mixed with separation liquid (usually water) in a mixing tank, and then pumped to the centrifuge.

The centrifuge is partly filled with a separation liquid, which forms a liquid ring due to

rotation at high speed. The plastics are fed axially into the centrifuge as a suspension and impinge on the surface of the revolving liquid ring. Here, intense turbulence results in deagglomeration of the individual plastic particles and largely frees them from adhering dirt.

Any air bubbles adhering to the surface of the particles are stripped off by the centrifugal force, which is especially important in view of the predominantly hydrophobic material. All particles with a density greater than the liquid are forced outward radially to the centrifuge bowl, while lighter compo-

nents float upwards inwardly. This occurs in a very short time and with high selectivity in a centrifugal field creating forces over 1,000 times higher than in conventional processes. The particle shape and size are not significant here.

A screw conveyor rotates inside the centrifuge at a speed slightly different to that of the centrifuge bowl.

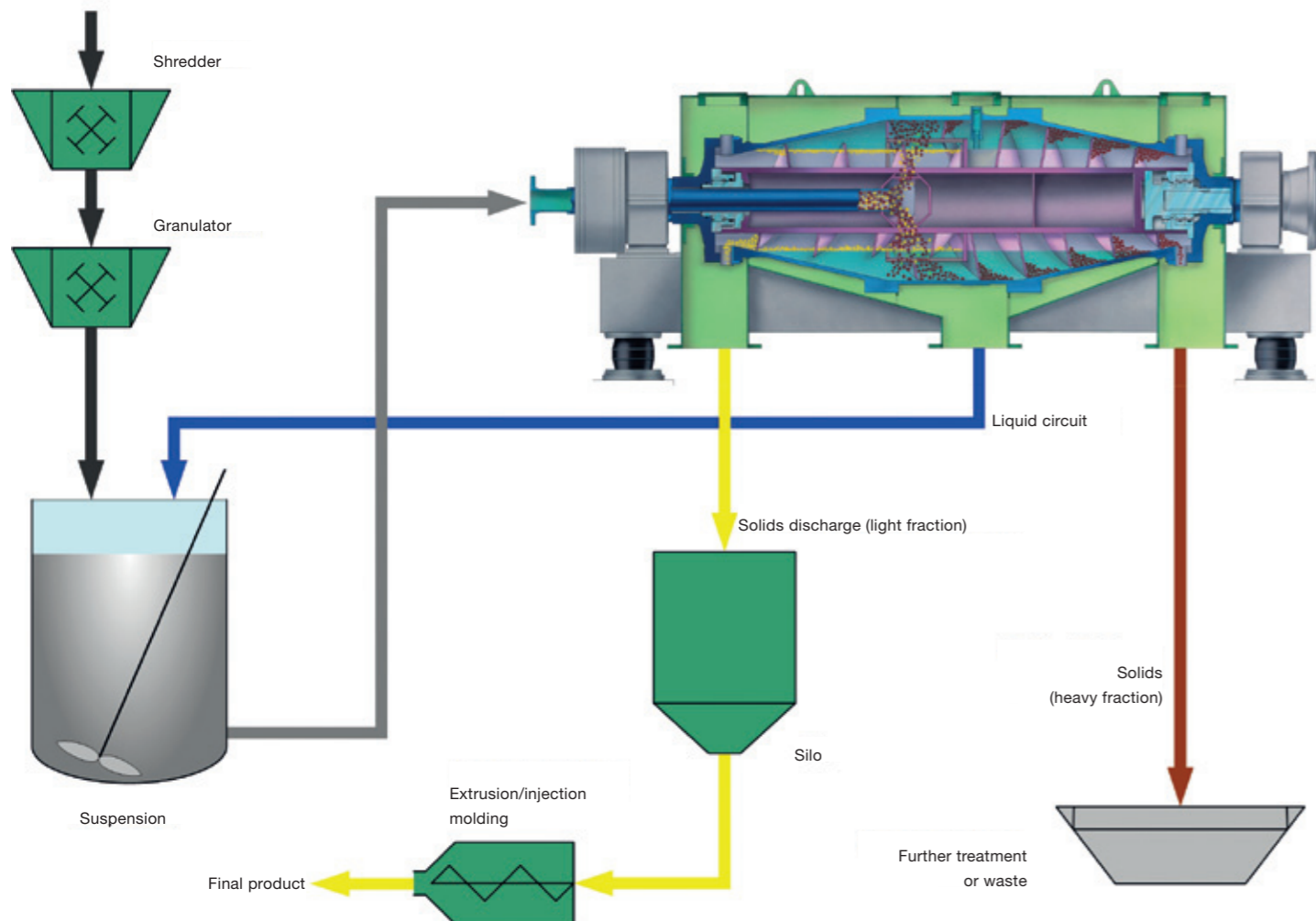

▲ Recycling of films for agricultural use

Counter-rotating screw flights are fitted to a screw body and transport the separated fractions to each of the conical ends of the centrifuge. There they are lifted up above the liquid ring and thus discharged after having been dewatered.

Depending on the type of plastics to be separated, the purity achievable can be more than 99.9%, with very low valuable product losses.

The liquid fed into the centrifuge with the plastics is discharged through nozzles in the center part of the centrifuge, thereby

keeping the liquid level constant. This liquid is recycled to be mixed with plastic again at the centrifuge inlet. At the same time, CENSOR removes any coarse impurities

from the liquid under centrifugal force, which results in a relatively low waste load.

One machine combines several important functions:

- low fresh water consumption
- separation with high selectivity
- dewatering of the products
- high washing efficiency
- partial clarification of the circulating water

CENSOR

Complete tailored, turnkey solutions from a single source

CENSOR is a highly selective process for obtaining plastic fractions of optimum purity. Systems tailored to almost any recycling problem are feasible by combining several process operations.

If separation liquids of different densities are used, several high-purity plastic fractions of varying density can be obtained by connecting several such separating operations in series. Various salt solutions are mainly used as separation liquid. As an example, this simplified schematic diagram shows how the components of post-con-

sumer carpet are separated. Carpets are mostly composed of polyamide fibers (PA), polypropylene (PP) binders, and a backing of latex and calcium carbonate. The most valuable fraction is the PA (often 6/6 PA). The specific density of PA is close to 1.1 g/cm³, PP is lighter, with a density close to 0.92 g/cm³, and the mixture of latex and CaCO₃ is considerably heavier than PA. To recover the nylon fibres (PA), the carpets first have to be reduced in size to 5-6 mm particles (usually in a two-stage process) and then transported to a first CENSOR system that uses plain water as the sepa-

ration liquid. In spite of the fact that the mixture consists of intertwined fibers, the high centrifugal force separates the PP into a light PP fraction and a heavy PA and latex fraction. The PP fraction is very clean and can be further processed.

The heavy fraction from the first stage is transported to a second CENSOR stage that uses separation liquid with a density of 1.18 g/cm³ (e.g. salt solution).

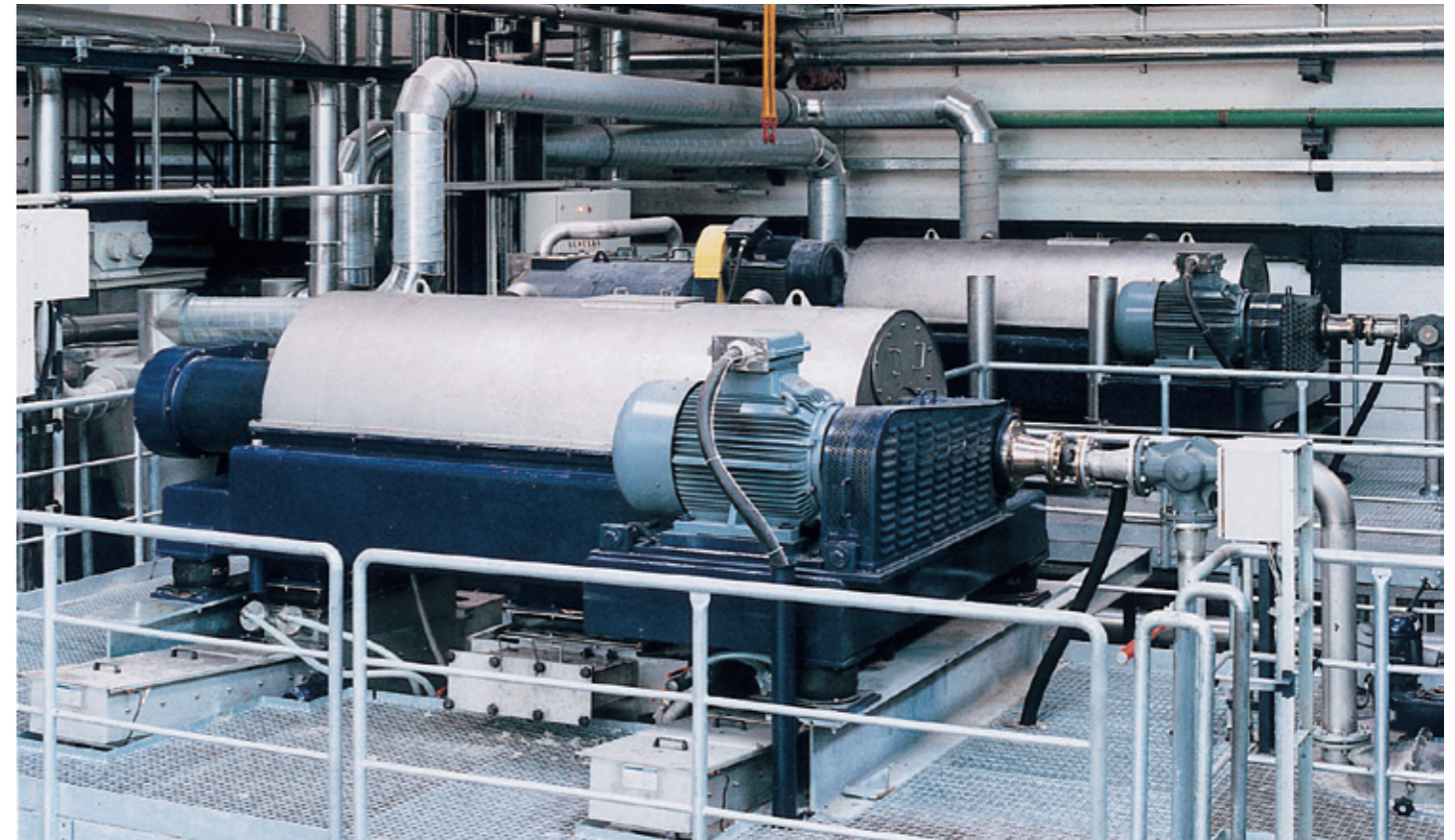
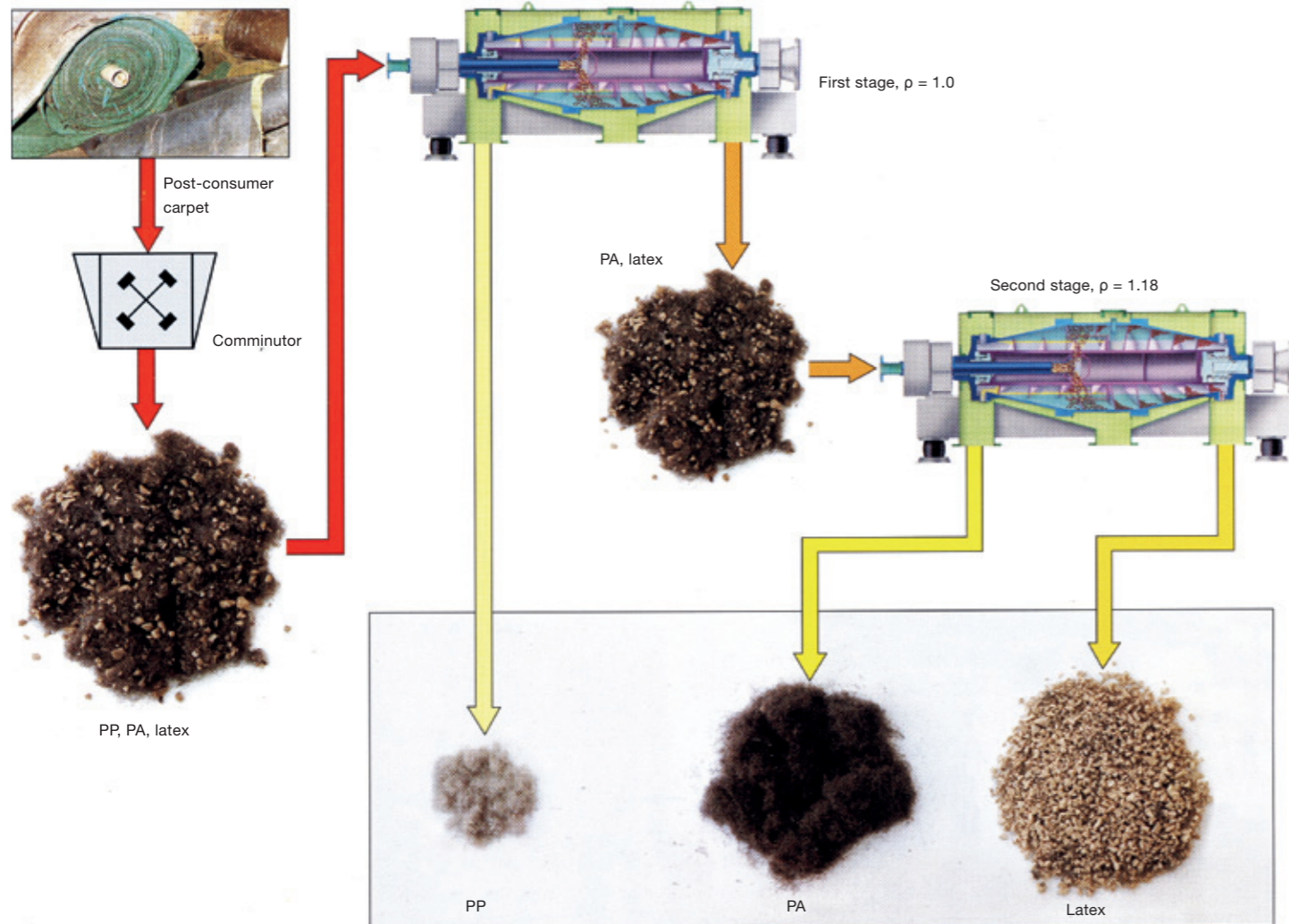

▲ CENSOR installation for the purification of plastic film mixes

The valuable, high-purity PA floating in this fraction is discharged as the light fraction and then sent to a dryer, extruder, or granulator, for example. Latex and CaCO₃ also sink here and form the heavy fraction in this stage.

In some cases, it makes sense to invert these two process steps.

Applications

As in this example, there are a multitude of applications where the CENSOR process can offer economic solutions. The high reliability, and hence availability, of the CENSOR system has been evidenced during practical operation at many installations

for more than 15 years, especially for high-efficient plastics recycling within scope of the German packaging ordinance and the leading organization of the dual-disposal-system (DSD). The CENSOR technology



▲ Two-stage CENSOR installation for sorting mixed plastics: absolutely pure PA granulate

allows separation and cleaning of plastics within a very wide range of applications. Plastics of similar density can also be separated more effectively due to the high selectivity of the process. The washing effect provides simultaneous cleaning with low water consumption.

Other applications are available for construction material waste (post-consumer carpets, cable scrap, and plastic cladding).

In addition, CENSOR can be used to recycle car components (i.e. dashboards, cables, bumpers, gasoline) and for recycling of synthetic turf as well as electronic scrap.

SENSOR

Compact installation: technical data

CENSOR type	Standard throughput ¹⁾ (t/h)	Installed power (kVA)	Water consumption ²⁾ (l/h)	Circulating water (m ³)	A ³⁾ (mm)	B ³⁾ (mm)	C ³⁾ (mm)	D ³⁾ (mm)
ACZ 4-3	0.5	66	150	2	3,400	7,600	4,600	2,900
ACZ 6-3	1	92	200	2.5	3,700	7,800	4,800	3,300
ACZ 9-3	2	138	400	3.5	4,750	8,800	5,000	3,700

- 1) Plastic mixture, bulk weight approx. 100 g/l
 2) Subject to normal contamination
 3) Reference values, subject to change without notice

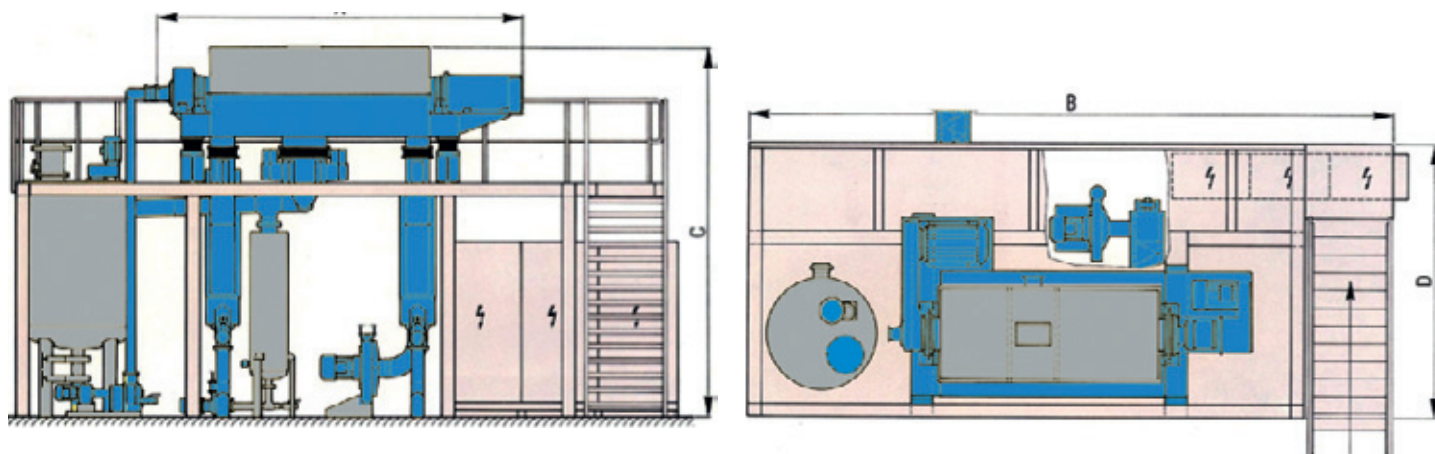

AFRICA
ANDRITZ Delkor (Pty.) Ltd.
 Phone: +27 (11) 012 7300
 Fax: +27 (86) 636 2122
 separation.za@andritz.com

AUSTRALIA
ANDRITZ Pty. Ltd.
 Phone: +61 (3) 8773 4888
 Fax: +61 (3) 8773 4899
 separation.au@andritz.com

EUROPE
ANDRITZ SEPARATION GmbH
 Phone: +49 (221) 9856 107
 Fax: +49 (221) 9856 202
 separation.de@andritz.com

SOUTH AMERICA
ANDRITZ SEPARATION Ltda.
 Phone: +55 (47) 3387 9110
 Fax: +55 (47) 3387 9103
 separation.bra@andritz.com

ASIA
ANDRITZ Singapore Pte. Ltd.
 Phone: +65 (6512) 1800
 Fax: +65 (6863) 4482
 separation.sg@andritz.com

CHINA
ANDRITZ (China) Ltd.
 Phone: +86 (757) 6663 3419
 Fax: +86 (757) 6663 3448
 separation.cn@andritz.com

NORTH AMERICA
ANDRITZ SEPARATION Inc.
 Phone: +1 (817) 465 5611
 Fax: +1 (817) 468 3961
 separation.us@andritz.com

www.andritz.com