

BASED ON **CLAMPING METHOD**

# OK-VISE®

## FIXTURING CONCEPT



All Platforms, All Workpieces

Small in Size – Giant in Performance

## COMPANY PROFILE

In the late 1970s Finnish entrepreneur and inventor Olli Kytölä bought his first numerically controlled machining centers, but he was not happy with the workholding solutions that were then available.

While fastening the laundry rope to the brick wall of his house, he started studying the screw anchor that he was using - and the rest is part of workholding history.

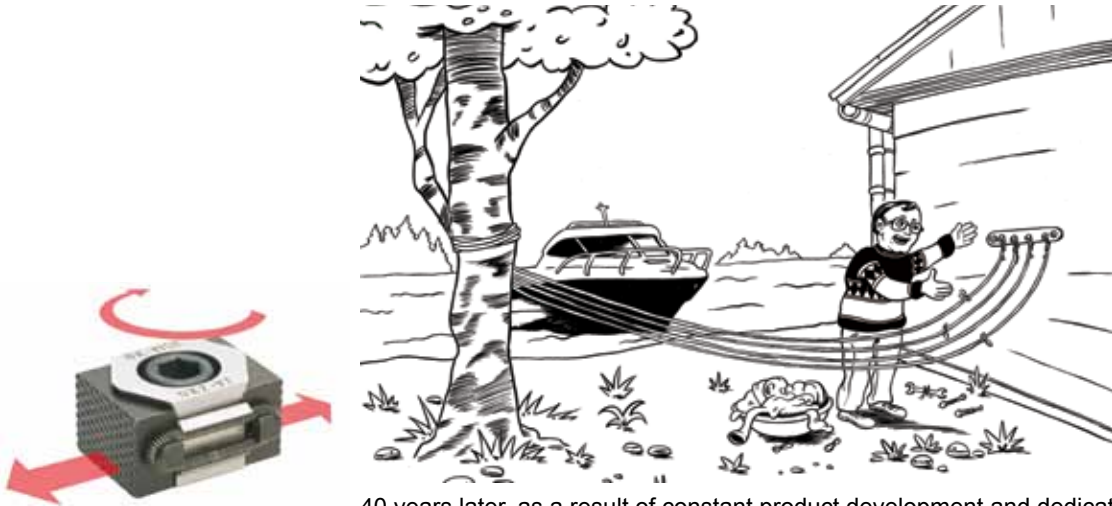

Hold-down principle

40 years later, as a result of constant product development and dedicated customer service, our name stands for quality in every respect, and today OK-VISE is a well recognized trademark around the globe.

In addition to low-profile clamps, we also manufacture components for various fixturing systems, which form the OK-VISE FIXTURING CONCEPT

Our products are available through a global distribution network and can reach even the most distant places within a few working days. A wide selection of information as well as the latest updates about our products are easily obtained from our website at: [www.ok-vise.com](http://www.ok-vise.com)



More info: [ok-vise.com/low-profile-clamps](http://ok-vise.com/low-profile-clamps)

## OK-VISE LOW-PROFILE CLAMPS

Olli Kytölä's original invention is still the core of our product range. This unique workholding solution is designed to meet the demands of the modern metalworking, plastics, aerospace and electronics industries.



## OK-VISE FIXTURING CONCEPT

The OK-VISE Fixturing Concept features a range of components that are suitable for the clamping of different workpiece types, sizes and materials on all types of platforms

Our **Blank system** is a system for building **DEDICATED FIXTURING** (workpiece-specific fixturing). Normally only one workpiece variant can be clamped with these systems.

A second option for fixturing is to use **GENERIC-PURPOSE** workholding. Generic purpose means that when buying this system it is not necessary to know exactly what kind of workpieces the user will be clamping in the future.

The components of these systems can be reused and reconfigured easily for a variety of applications and workpieces.

Of our generic-purpose components the most typical is the **Multi-Rail System**. In addition to the commonest RM size – M stands for medium – we also supply a heavy duty rail size RH. Multi-Rail RM is the ideal system to replace old-fashioned machine vises in generic-purpose clamping, and it also performs optimally on all platforms.

Another system that is available is the **Grid System**. When a grid platform is used – typically an M12 positioning bushing and an M12 thread in a 50x50mm matrix – these components are optimal for clamping complex workpiece forms like castings and plates.

Perhaps the most fascinating product in our fixturing concept is the **Combo-Rail** which features several operating modes: centralizing mode, machine vise mode and floating mode. Floating mode is needed for large castings which are typically long or large in size. This patent-pending solution has earned praise worldwide for its simplicity.

All these systems are based on OK-VISE low-profile clamps. Additionally, instead of traditional manual clamping all these systems can be automated using hydraulic clamping modules from OK-VISE.

Low-Profile Clamps



4

Multi-Rail RM System



9

Multi-Rail RH System



14

Combo-Rail



16

Grid System



18

Blank System



21

Hydraulic



24

### SUB-PLATES AND PLATFORMS

26

We also offer platforms like tooling columns, trunnion units (RPS), zero-point positioning system ( OK-LOCK ) and sub-plates.

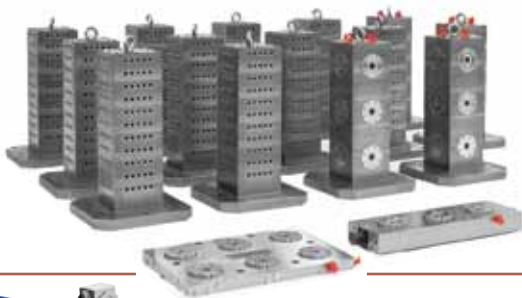

### WEDGEMAN SELECTION TOOL

27

To find most suitable fixturing system for your needs, OK-VISE has designed a selection tool Wedgeman

## LOW-PROFILE CLAMPS

The OK-VISE clamping method is both an effective and time-saving solution because it allows full utilization of the fixturing platform. It also allows free tool access to the workpiece, is free of play and possesses extreme clamping force in a small space.

Efficient use of the machinable area leads to savings in tool changes, creates less operator interventions and results ultimately in extended cycle times while cutting down machine stop times.

Low-profile clamps do not require a lot of space when compared to traditional machine vises and the variety of jaw types on offer makes the clamp suitable for a wide range of machining applications.

## OPERATING PRINCIPLE

OK-VISE low-profile clamps function on the principle that when tightened down they expand, simultaneously pressing the workpieces against the guide and preventing any possibility of play. These clamps are designed to fit between the workpieces and take very little space on the fastening base. Small in size, yet possessing an excellent clamping force up to 150 kN, these clamps guarantee a holding capacity which clearly exceeds the load imposed by machining forces.

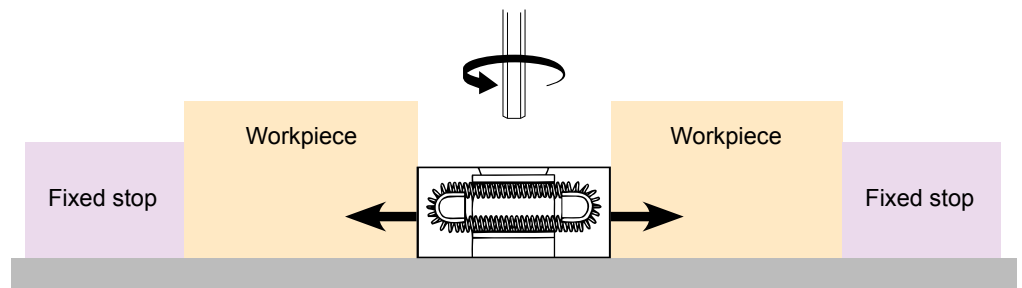

## SMOOTH JAWS

When no marks on the workpieces are allowed, smooth jaws are used.

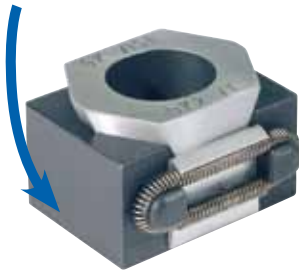

## SERRATED JAWS

General-purpose clamp for your workshop. Serration creates high friction, which ensures reliable clamping in any circumstances.

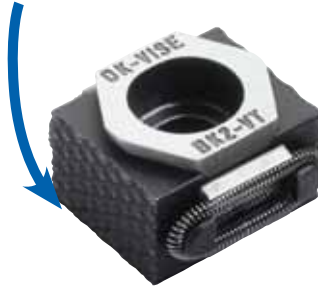

## GRIP MODELS

When the friction offered by serrated jaws is not enough for your application, grip jaws can be used. Please notice that the jaw penetrates into the work piece, leaving some marks.



## MACHINABLE JAWS

Single-wedge clamps are also available with extended jaws and can be machined to suit the geometry of the workpiece. The smallest model can be machined up to 3 mm and the larger ones up to 5 mm.



## ADDITIONAL PIECE MODELS

Additional piece models have machined female threadings (M5) for socket head screws on the side of the jaw, making it quick and easy to use various additional pieces which can also be machined into irregular shapes.



## SELF-ADJUSTABLE MODELS

These clamps have a self-adjustable ball pressure screw inserted into a clamp jaw. The ball bearing at the end is made of steel and equipped with torsion protection, allowing the ball to self-adjust up to 9 degrees. This makes clamping irregular-shaped parts and castings more flexible.



## STAINLESS STEEL MODEL

The stainless steel model is designed to meet the demands of wire EDM applications. This model only contains parts made of high quality stainless steel. Available only with smooth-ended jaws.



## PULL-DOWN MODELS

In addition to holding the workpiece in place, pull-down clamps also generate pull-down action, pressing workpieces down onto the fixture base.



## ECONOMY MODELS

These models meet the demands of workholding when ultra precision and high clamping force are not necessary. They are made of the same raw material as our other models. Only the bottom of the jaw is ground. Our smallest series is only available as the economy model (AK2-VT-SO).



## INCH MODELS

D-series clamps are also designed for the half-inch bolt. The center hole of the inch-series wedge is wider in order to fit the half-inch socket head screw. VT1 and WT1 in the code stand for inch models.



## **A CORE COMPONENT OF ANY JAWS WORKHOLDING SYSTEM**

OK-VISE low-profile clamps adapt optimally to any workholding system. They fit into grid pattern systems, T-slot tables, serrated rails and many other platforms. OK-VISE clamps are suitable for three-directional machining, 5-axis machining and many other modern machining methods. When fixtures are needed for any modern machining application, OK-VISE clamps are your best choice.

## **ABSOLUTE STABILITY**

The key feature of the OK-VISE low-profile clamp is its cross-wedge structure in both the horizontal and vertical planes, which means that the clamp is locked firmly in every direction as it is tightened down. This eliminates all possibilities of play.

## **EXTREME CLAMPING FORCE**

With extreme clamping force of up to 150 kN, OK-VISE low-profile clamps guarantee a holding capacity that clearly exceeds the load imposed by machining forces.

## **SMALL IN SIZE – GIANT IN PERFORMANCE**

Low-profile clamps do not require as much space as traditional machine vises. This leads to efficient use of the machinable area, savings in tool changes, less operator interventions, and ultimately to extended cycle times while reducing machine downtime.

Thanks to their small size, these light-weight clamps are easy to install. Moving them from one application or machine to another is virtually effortless. Their universal design makes easy use a reality in all types of CNC machining centers as well as FMS Systems.

## **ULTIMATE RELIABILITY**

As the original inventor of the wedge-operated low-profile clamp, OK-VISE has decades of history of efficient and reliable installations world-wide.

With OK-VISE low-profile clamps, it is possible to achieve the highest level of reliability and safety.

### **ACCESSORIES**

Several accessories can be utilized with OK-VISE clamps. Take a look at the expanding range of accessories at

[www.ok-vise.com/low-profile-clamps/accessories](http://www.ok-vise.com/low-profile-clamps/accessories)



## OK-VISE LOW-PROFILE CLAMP TYPES

SIZE	A	B	D	D (inch)	F
Serrated basic version		BK2-VT	DK2-VT	DK2-VTI	FK2-VT
Smooth basic version		BK2-VT-S	DK2-VT-S	DK2-VTI-S	FK2-VT-S
Grip jaw & serrated jaw combo		BK2-VT-RG	DK2-VT-RG	DK2-VTI-RG	FK2-VT-RG
Machinable jaws		BK2-VT+3	DK2-VT+5	DK2-VTI+5	FK2-VT+5
Machinable & smooth combo		BK2-VT+3S	DK2-VT+5S	DK2-VTI+5S	FK2-VT+5S
Machined Cross V jaws		BK2-VT-C	DK2-VT-C	DK2-VTI-C	FK2-VT-C
Additional piece model		BK2-VT-T	DK2-VT-T	DK2-VTI-T	FK2-VT-T
Additional piece model & smooth combo		BK2-VT-TS	DK2-VT-TS	DK2-VTI-TS	FK2-VT-TS
Self-adjustable model		BK2-VT-B	DK2-VT-B	DK2-VTI-B	
Two self-adjustable jaws		BK2-VT-E	DK2-VT-E	DK2-VTI-E	
Single-wedge pull-down, serrated		BK2-VT-PD	DK2-VT-PD	DK2-VTI-PD	FK2-VT-PD
Double-wedge pull-down, serrated			DK2-WT	DK2-WTI	FK2-WT
Double-wedge pull-down, smooth			DK2-WT-S	DK2-WTI-S	FK2-WT-S
Stainless steel model		BK2-VT-SS			
Economy-series, serrated		BK2-VT-O			
Economy-series, smooth	AK2-VT-SO	BK2-VT-SO			
Metric bolt	M5	M8	M12		M16
Imperial bolt	3/16"	5/16"		1/2"	5/8"
Force up to (kN)	10	25	90	90	150

## OK-VISE CLAMPFORCES

Horizontal forces of OK-Vise low profile clamps

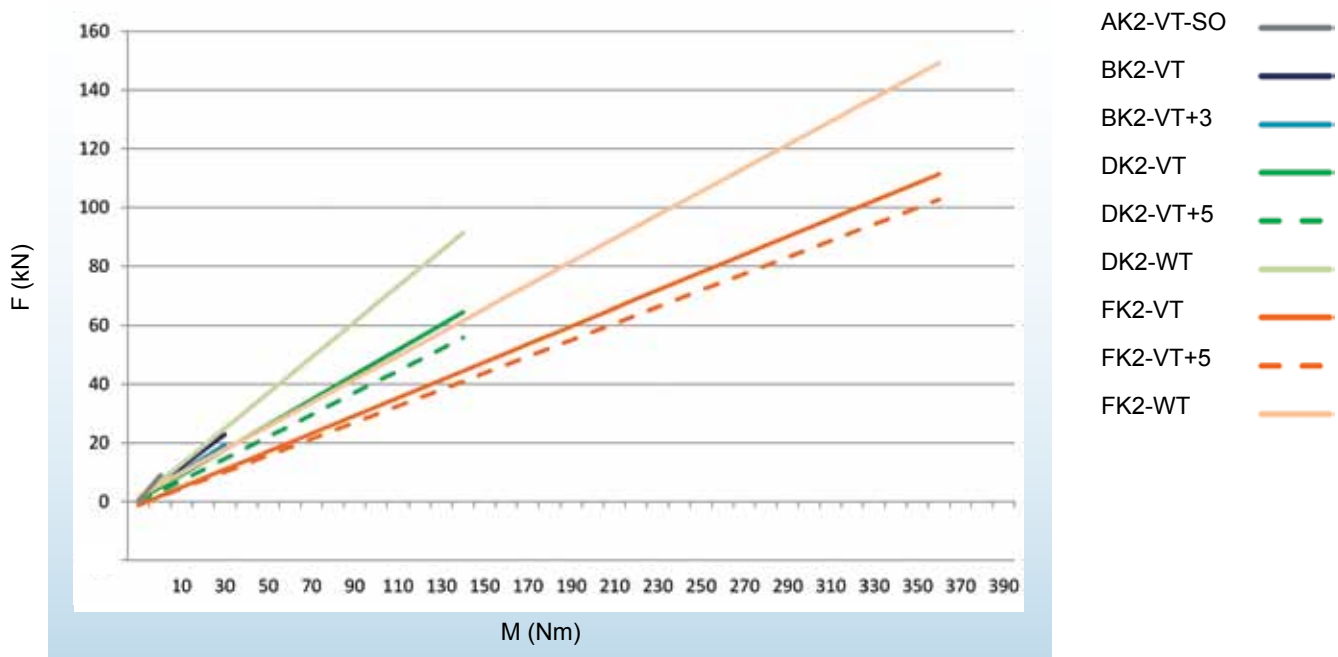

# OK-VISE FIXTURING CONCEPT

## Generic purpose concepts

**MULTI-RAIL RM SYSTEM**  
Page 9



**MULTI-RAIL RH SYSTEM**  
Page 14



**COMBO-RAIL**  
Page 16



**GRID SYSTEM**  
Page 18



Multi-Rail RM System applications

### GENERIC FIXTURING CONCEPTS

- Multi-Rail RM System
- Multi-Rail RH System
- Grid Fixturing System
- Combo-Rail

### LOW-PROFILE CLAMPS

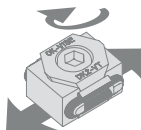

### COMPONENTS FOR DEDICATED FIXTURING

- Blank Fixturing System



# OK-VICE MULTI-RAIL RM SYSTEM

Multi-Rail is the new generic-purpose workholding system of OK-VICE.

Compared to a traditional machine vise, the Multi-Rail system offers the following benefits:

- Using the components of the system, even the most challenging workpiece types can be machined
- All sides of a workpiece can be machined with two setups
- Multiple workpieces can be clamped on the same area
- Workpiece will be safely fixtured in all conditions
- It is also possible to fasten very large work pieces



## MULTI-RAIL RM SYSTEM COMPONENTS

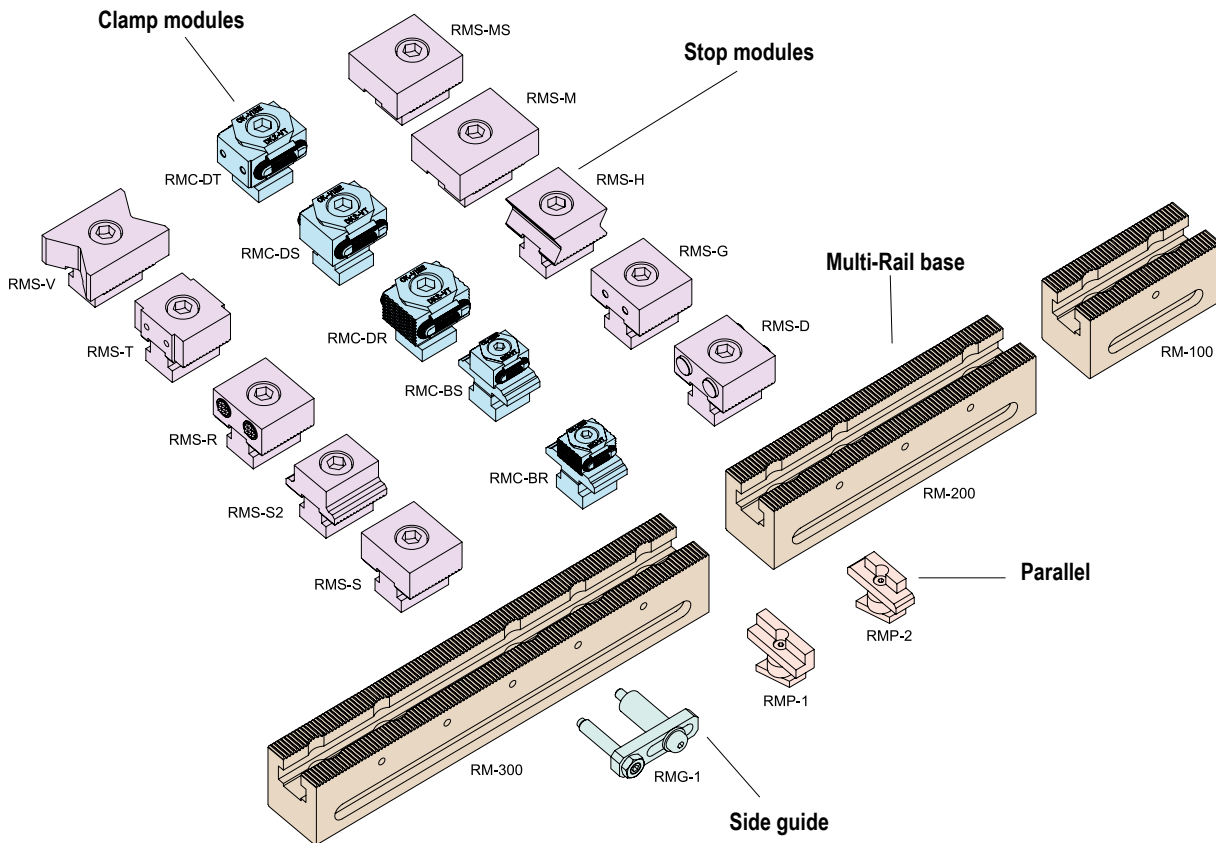

## MULTI-RAIL RM FIXTURE SETS

To make selection of the components easier, the OK-VICE team has selected some basic sets to enable an easy start with the Multi-Rail system. In the pictures below you can see some solutions done with each set.



### SRM-132GD1

- For three-directional machining
- One or two workpieces can be machined at the same time

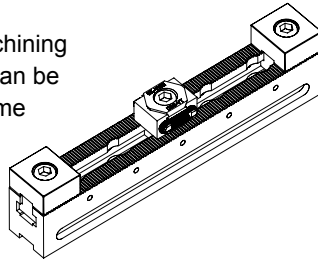

code	name	pcs
RM-300	multi-rail base	1
RMS-S	stop module smooth	2
RMC-DS	clamp module D smooth	1



### SRM-133GB1

- For three-directional machining
- Four workpieces can be machined at the same time

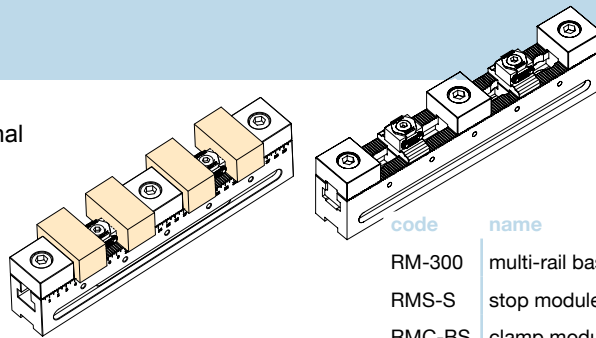

code	name	pcs
RM-300	multi-rail base	1
RMS-S	stop module smooth	3
RMC-BS	clamp module B smooth	2



### SRM-236GB1

- Two SRM-133GB1 sets
- Also suitable for holding long workpieces

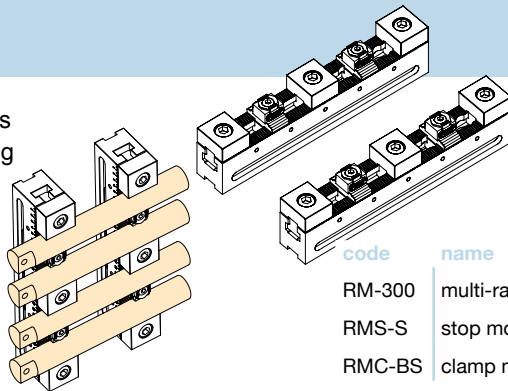

code	name	pcs
RM-300	multi-rail base	2
RMS-S	stop module smooth	6
RMC-BS	clamp module B smooth	4



### SRM-4C4GD1

- To hold large workpieces

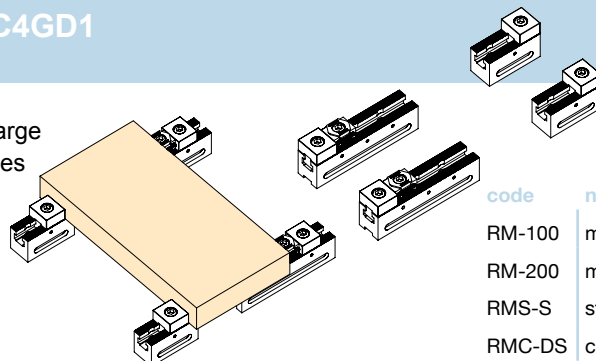

code	name	pcs
RM-100	multi-rail base	2
RM-200	multi-rail base	2
RMS-S	stop module smooth	4
RMC-DS	clamp module D smooth	2

# MULTI-RAIL RM SYSTEM APPLICATIONS

## SRM-Z101

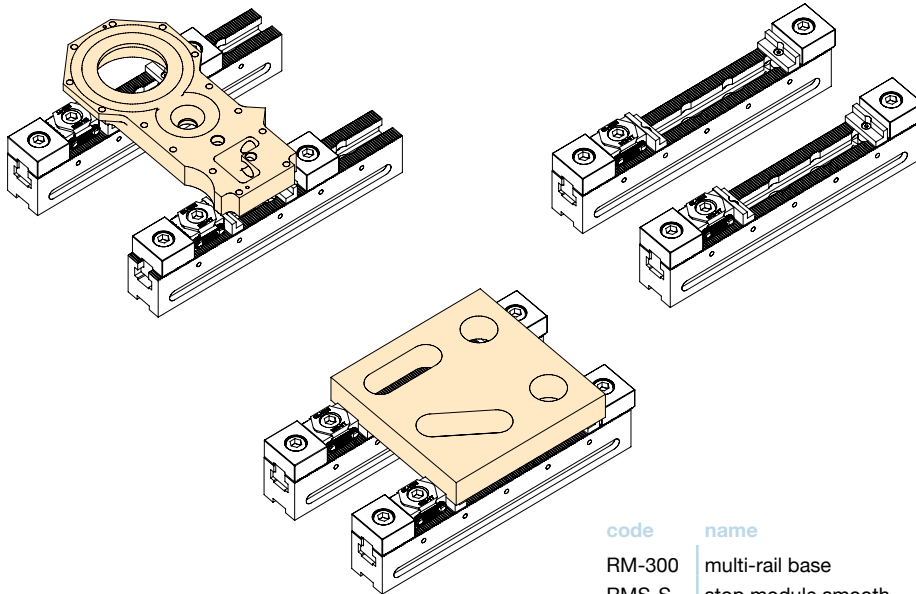

code	name	pcs
RM-300	multi-rail base	2
RMS-S	stop module smooth	4
RMC-DS	clamp module D smooth	2
RMP-1	parallel block	4

1 Workpiece

2 Workpieces

3 Workpieces

4 Workpieces

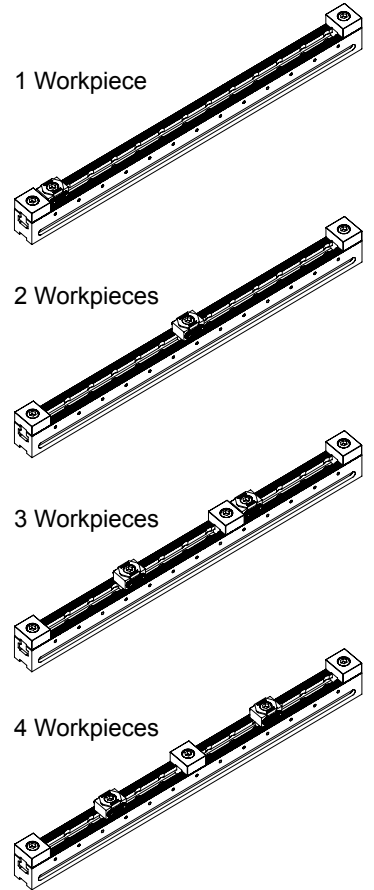

## SRM-Z102

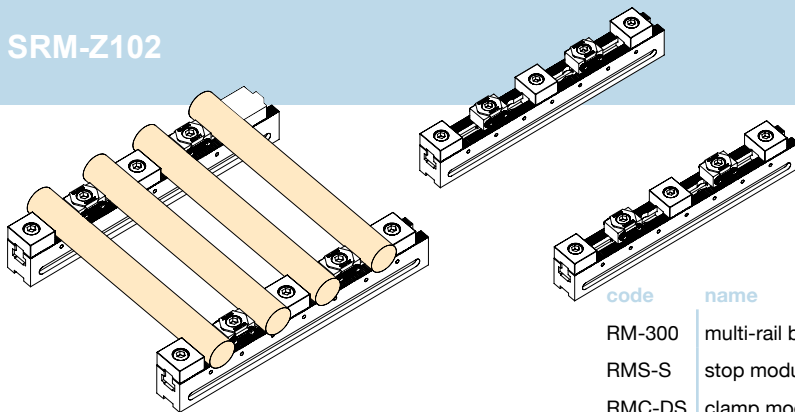

code	name	pcs
RM-300	multi-rail base	2
RMS-S	stop module smooth	6
RMC-DS	clamp module D smooth	4



## SRM-Z103

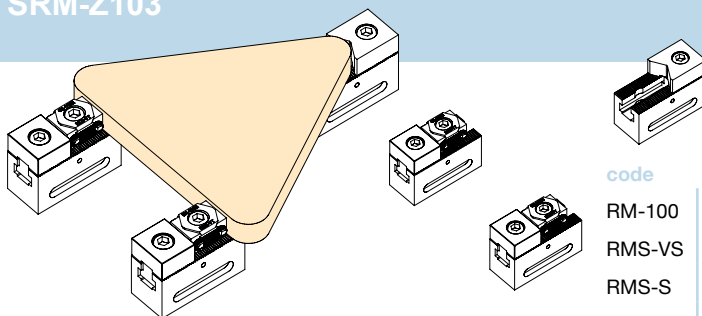

code	name	pcs
RM-100	multi-rail base	3
RMS-VS	stop module combo V/S	1
RMS-S	stop module smooth	2
RMS-DS	clamp module D smooth	2



## MULTI-RAIL RM SYSTEM APPLICATIONS



SRM-Z105

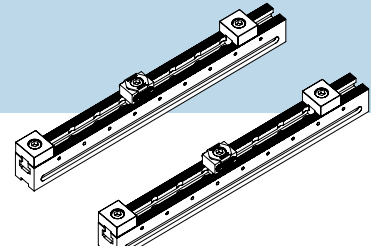
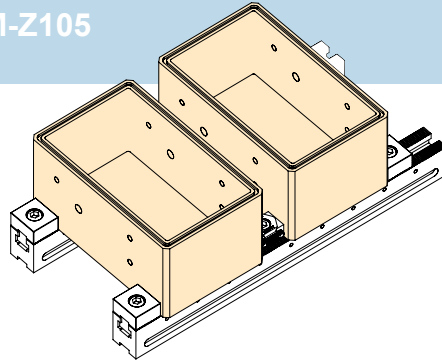

code	name	pcs
RM-500	multi-rail base	2
RMS-S	stop module smooth	4
RMC-DS	clamp module smooth	2

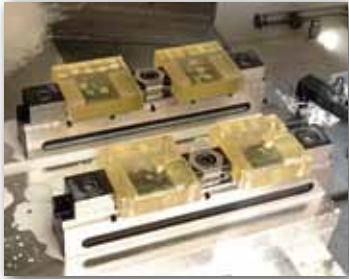

SRM-Z106

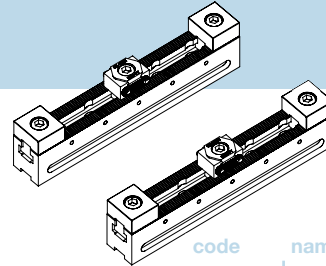
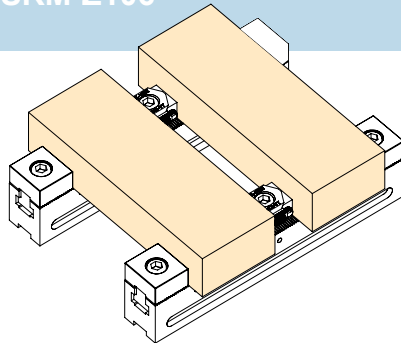

code	name	pcs
RM-300	multi-rail base	2
RMS-S	stop module smooth	4
RMC-DS	clamp module smooth	2



SRM-Z107

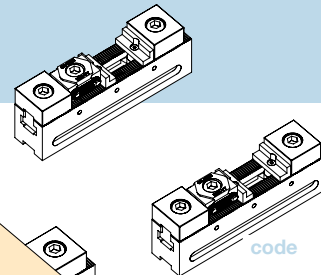
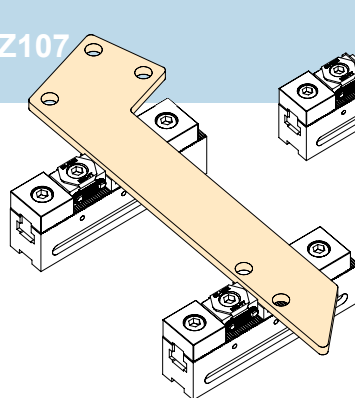

code	name	pcs
RM-200	multi-rail base	2
RMS-S	stop module smooth	4
RMC-DS	clamp module smooth	2
RMP-1	parallel block	4



SRM-Z108

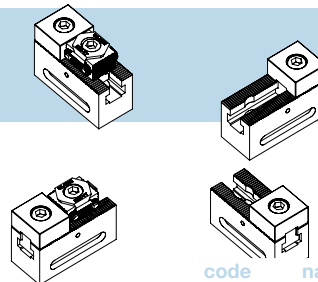
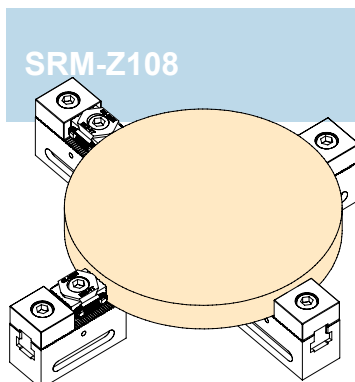

code	name	pcs
RM-100	multi-rail base	4
RMS-S	stop module smooth	4
RMC-DS	clamp module smooth	2

# MULTI-RAIL RM SYSTEM APPLICATIONS

## SRM-Z109

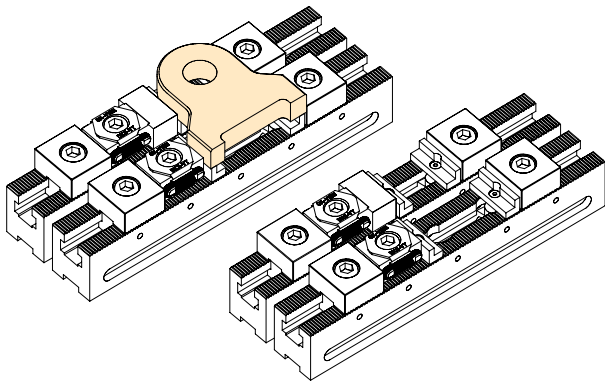

code	name	pcs
RM-300	multi-rail base	2
RMS-S	stop module smooth	4
RMC-DS	clamp module D smooth	1
RMC-DTS	clamp module D-T smooth	1
ADM	additional piece	1
RMP-1	parallel block	4



## SRM-Z110

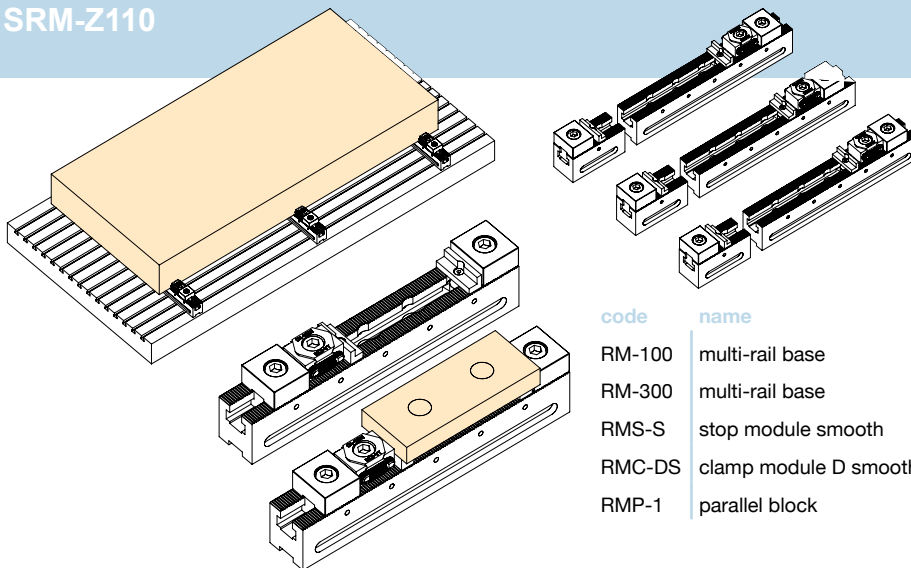

code	name	pcs
RM-100	multi-rail base	3
RM-300	multi-rail base	3
RMS-S	stop module smooth	6
RMC-DS	clamp module D smooth	3
RMP-1	parallel block	6



### OPTIONS

We also offer installation sets for the most common platforms like T-slot tables and grid systems.



Spigot installations to all leading zero-point systems – including OK-LOCK System – are available.



More info: [ok-vise.com/multi-rail-system/](http://ok-vise.com/multi-rail-system/)



## OK-VISE MULTI-RAIL RH SYSTEM

Multi-Rail RH is the new generic-purpose fixturing system from OK-VISE. Multi-Rail RH is optimal when the clamping force is over 4 tons and also when the workpieces are rather big.



### FIXTURE SETS

To make selection of the components easier, the OK-VISE team has created some basic sets to enable an easy start with the Multi-Rail system.

Compared to a traditional machine vise, the Multi-Rail RH system offers the following benefits:

- Using the components of the system, even the most challenging workpiece types can be machined.
- All sides of a workpiece can be machined with two setups.
- Multiple workpieces can be clamped on the same area.
- The workpiece is safely fixtured under all conditions.
- It is also possible to fasten very large work pieces.



## MULTI-RAIL RH SYSTEM COMPONENTS

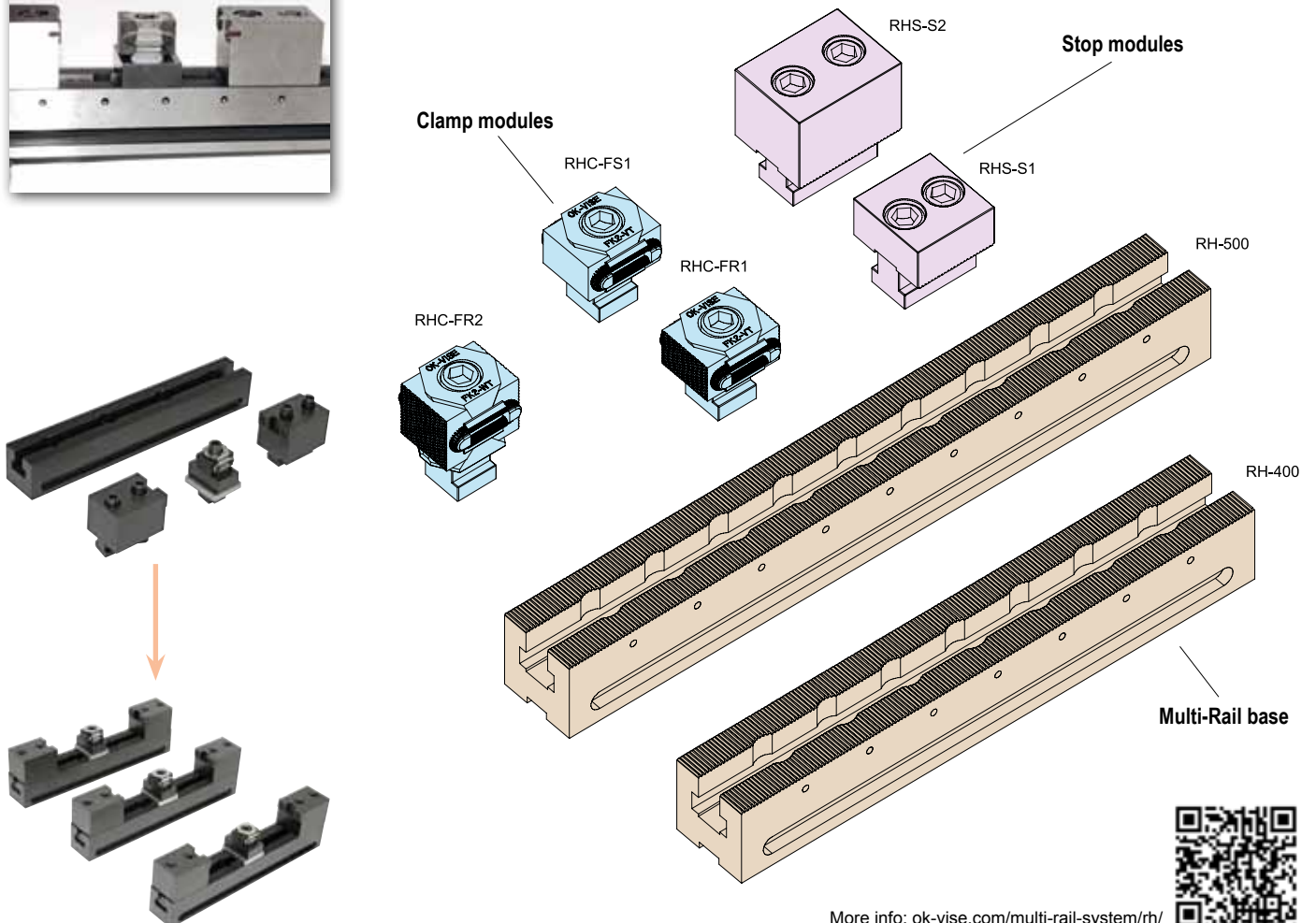

More info: [ok-vise.com/multi-rail-system/rh/](http://ok-vise.com/multi-rail-system/rh/)

## MULTI-RAIL RH SYSTEM APPLICATIONS

In a modular system all the functions of a fixture are separated into individual modules. This means that when workpiece material, form or size changes, the modules of the fixture can be changed independently of each other. Using a well-chosen collection of basic modules – a set – a huge variety of workpieces can be clamped simply using the same modules.

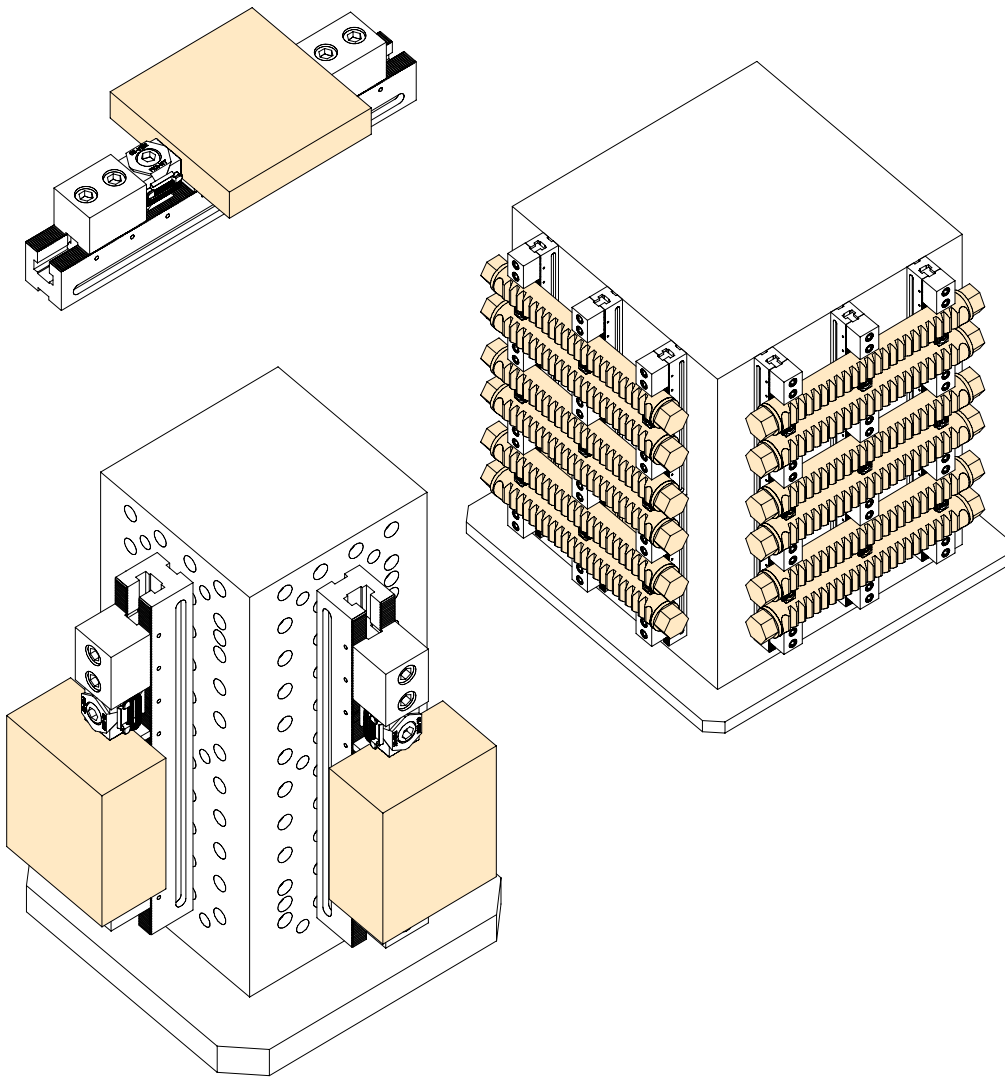

We also offer installation sets for the most typical platforms like T-slot tables and grid systems.

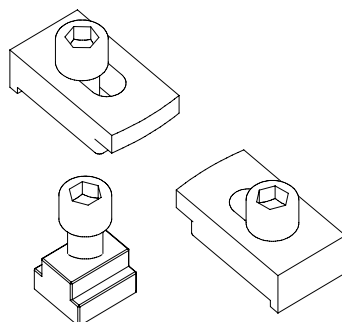

## OK-VISE COMBO-RAIL

OK-VISE Combo-Rail is a unique patent-pending design from us.

There are several operating modes available:

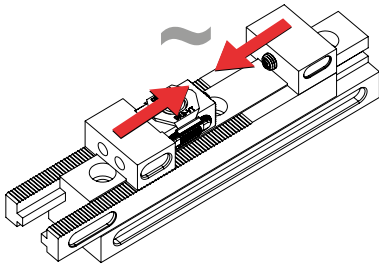

### Floating mode

- This is the most fascinating operating mode of the Combo-Rail. Here the fixture adjusts to the place of the workpiece.
- This is often needed while clamping inaccurate workpieces like castings, forgings or flame cut work pieces.
- Therefore floating mode installation normally needs positioning with some other means, like two Multi-Rail units, positioning pins, positioning by a robot etc.

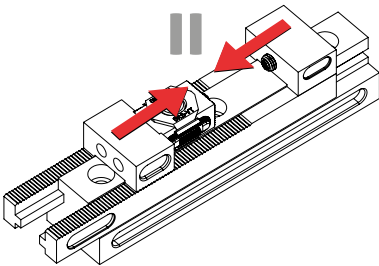

### Centralising mode

- The jaws move synchronously. The centre line of a casting or similar workpiece remains in the same place even if the outer dimensions of the workpiece changes.

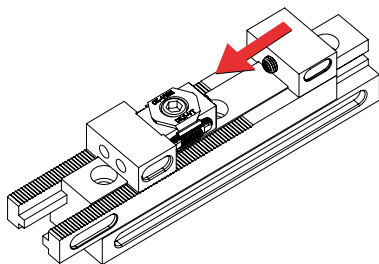

### Machine vise mode

- In this mode the other jaw is fixed to the base. Compared to traditional Vises, in this method the ergonomics are radically improved in vertical machining centres.

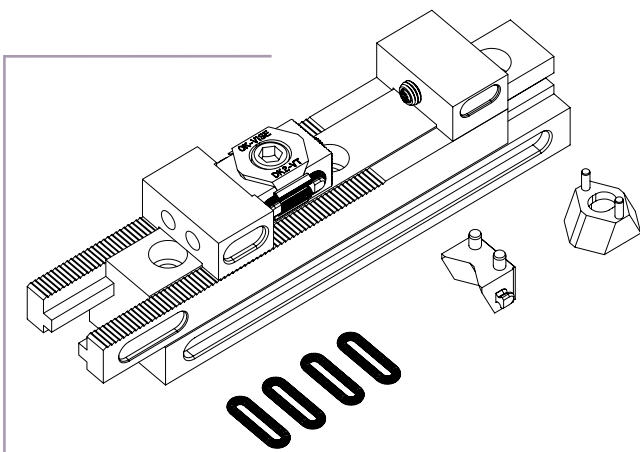

### CRH-K250

CRH-K250 is a Combo-Rail unit that can be set in all three modes as mentioned before, operating modes by changing the jaw or wedge components (all included). All workpieces from 0 to 120 mm size can be clamped. The base height is 50 mm and total length is 250 mm.





## COMBO-RAIL APPLICATIONS

The Combo-Rail units can be combined with most of OK-VISE Fixturing Concept components. Especially combining Combo-Rail units with OK-VISE Multi-Rail has been proven to be a brilliant combination. Special versions are also available, please do not hesitate to ask for price and delivery time from our local dealer.

### Floating mode

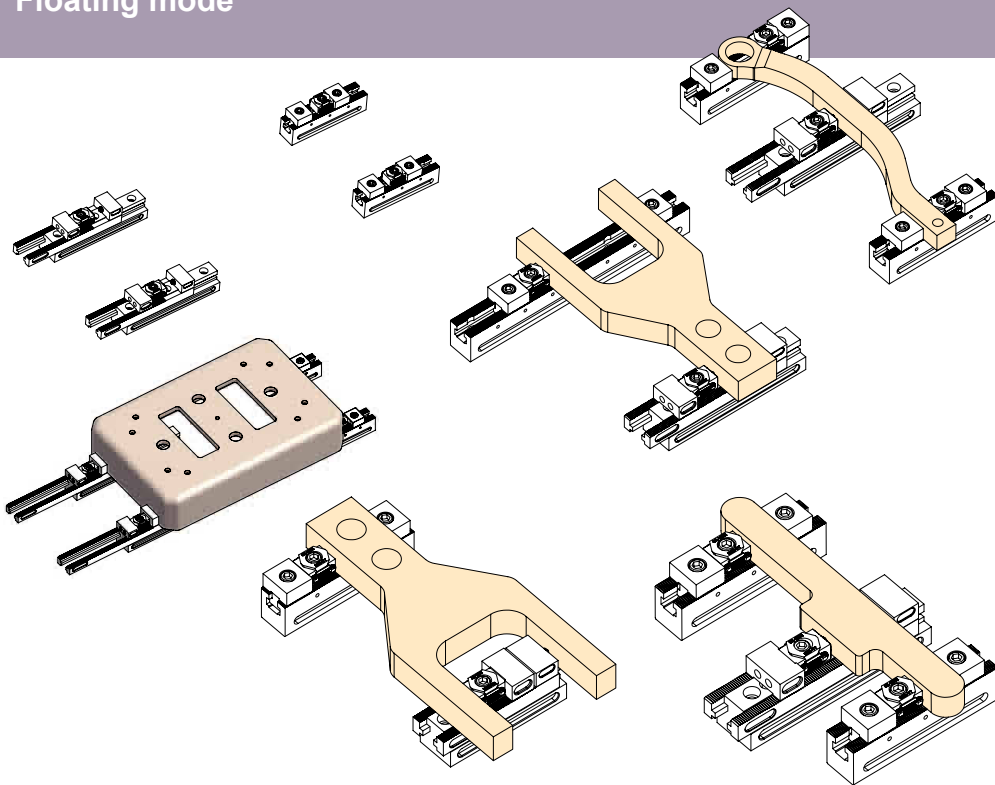

### Centralising mode

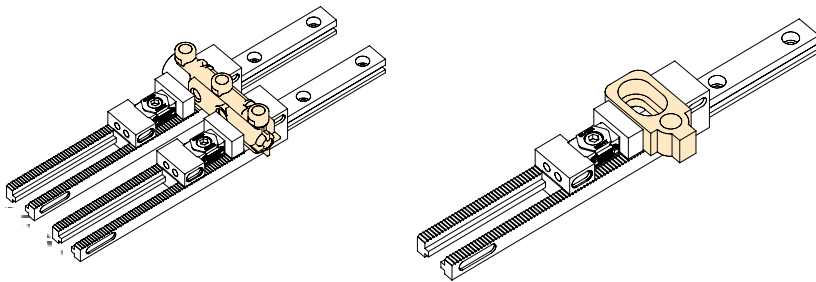

### Machine vise mode

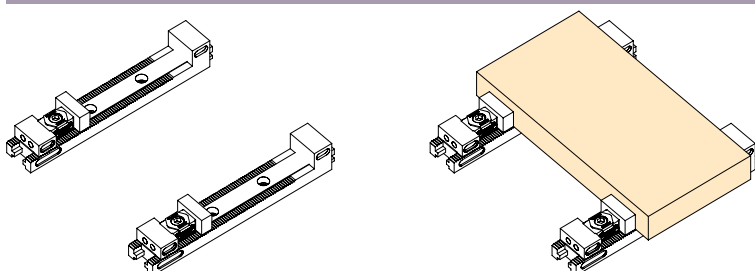

There are several adapter sets available for various platforms.





## GRID FIXTURING SYSTEM

Grid Fixturing System is the new generic-purpose fixturing system from OK-VISE.

It can be adapted to the grid platforms of leading workholding suppliers. With the OK-VISE Grid Fixturing System even very complex forms of workpieces can be clamped.

On a grid platform you can also combine OK-VISE modules with the components of other suppliers.

## GRID SYSTEM COMPONENTS

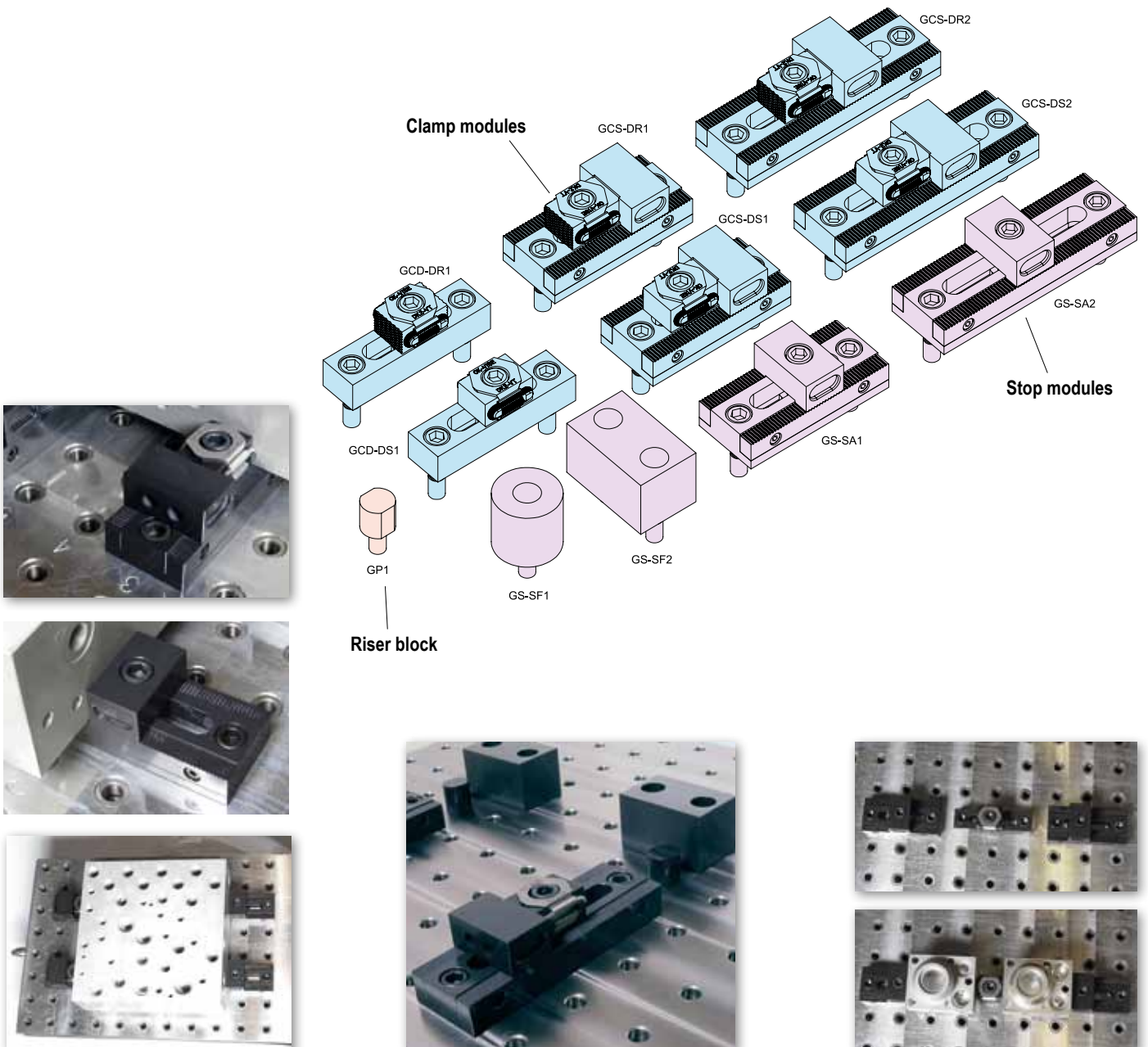

# GRID FIXTURING SYSTEM APPLICATIONS

To make selection of the components easier, the OK-VISE team has selected some basic sets to enable an easy start with the Grid system. In the pictures below you can see the solutions done with each set. We recommend platforms of leading suppliers. Grid plate is normally not included in the set.

## SG-Z02

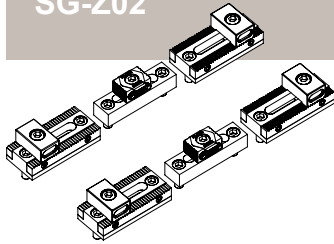

code	pcs
GS-SA1	2
GCD-DS1	2

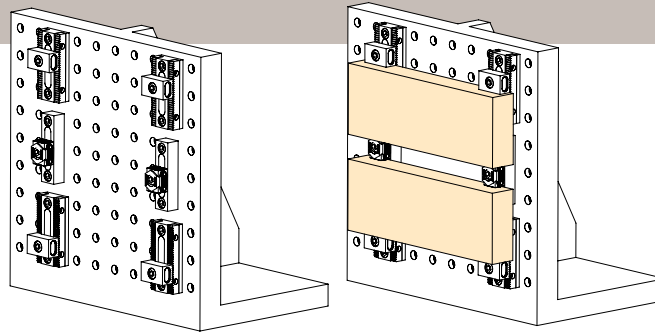

## SG-Z03

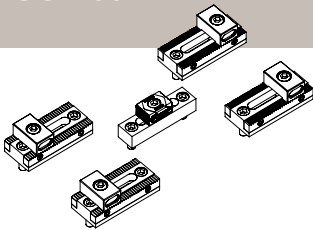

code	pcs
GS-SA1	4
GCD-DS1	1

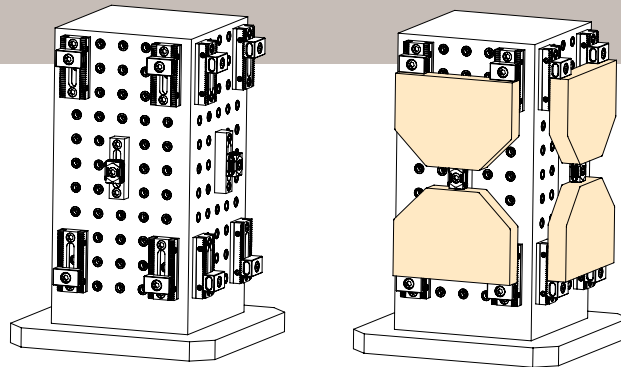

## SG-Z04

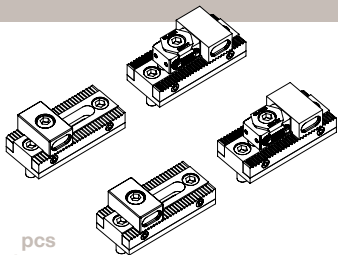

code	pcs
GS-SA1	2
GCS-DS1	2

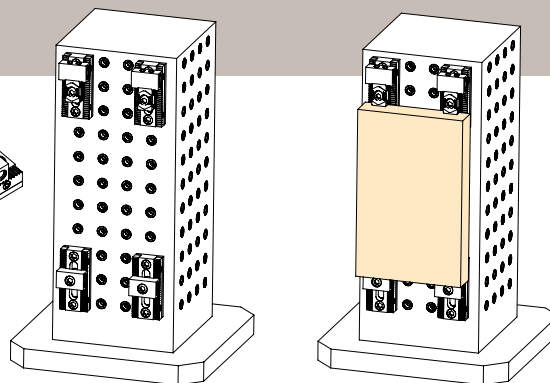

## SG-Z06

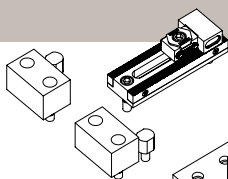

code	pcs
GS-SF2	2
GCS-DS2	1
GP-1	2

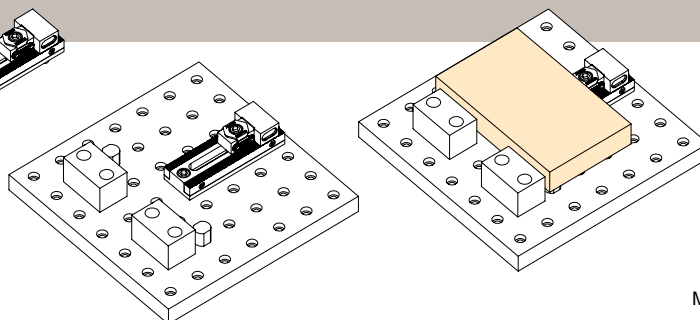

More info: [ok-vise.com/grid-system](http://ok-vise.com/grid-system)

# COMPONENTS FOR DEDICATED FIXTURING

**BLANK ORIGINAL**  
The most traditional way to use OK-Vise low-profile clamps



**BLANK SYSTEM**  
Page 21



## GENERIC FIXTURING CONCEPTS

- Multi-Rail RM System
- Multi-Rail RH System
- Grid Fixturing System
- Combo-Rail

## LOW-PROFILE CLAMPS

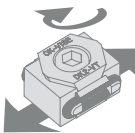

## COMPONENTS FOR DEDICATED FIXTURING

- Blank Fixturing System

# OK-VISE BLANK FIXTURING SYSTEM

The OK-VISE Blank Fixturing System is designed for cases when dedicated (product-specific) fixtures are needed. This is typical in high-volume production. Blank plates are used as a platform on which to build the fixture – aluminium and steel blanks are recommended.

In addition to OK-VISE low-profile clamps and bolts, a variety of components are now available. Various clamp modules, stopper modules, side guides and parallels (or riser blocks) are the basic modules of the system. High-friction jaws in stopper modules and clamps ensure reliable clamping when high machining forces are used.

When sensitive contact with the workpiece is a must, then smooth, diamond-surface or contour-machined jaws are optimal.



Blank Fixture Set

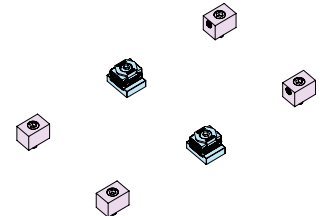

Blank Plate

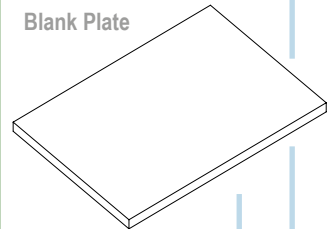

Machined Plate

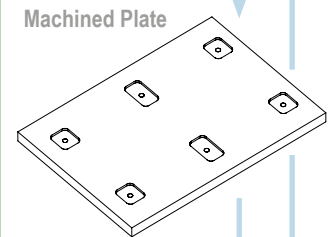

Fixture

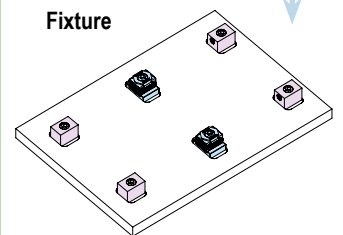

Fixture with Workpieces

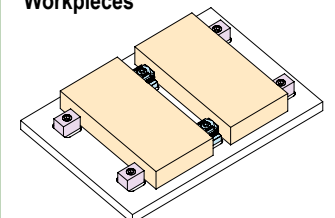

## BLANK SYSTEM COMPONENTS

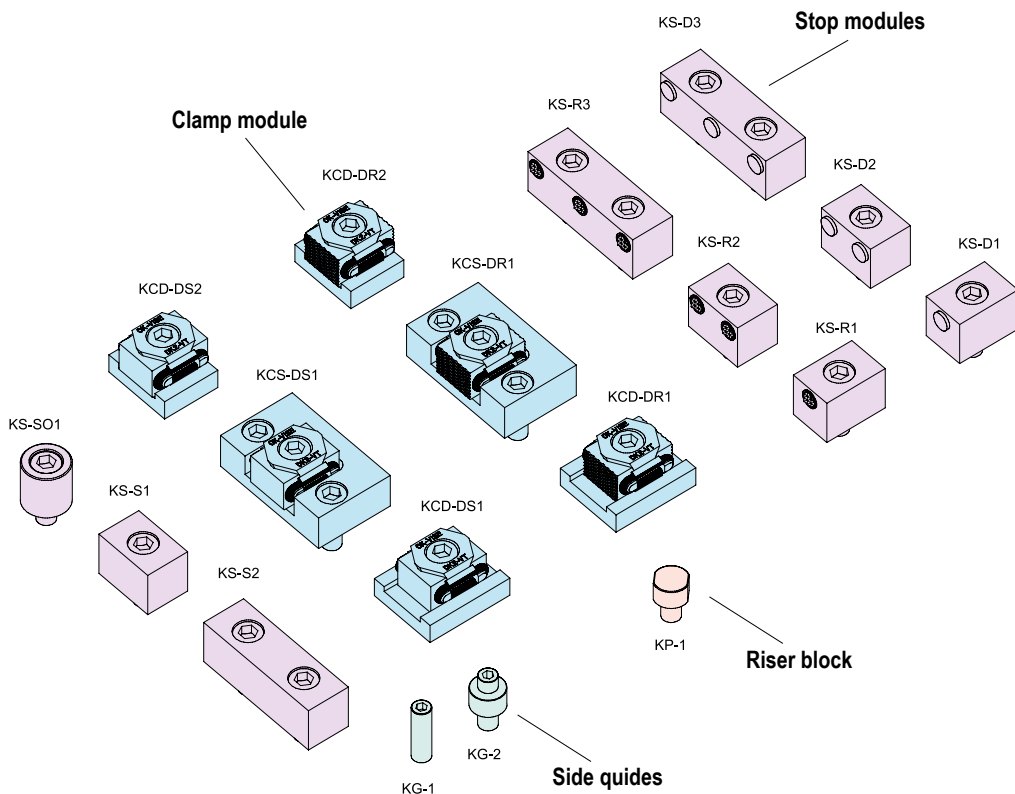

More info: <http://www.ok-vise.com/blank-system/>



## BLANK SYSTEM FIXTURE SETS

To make selection of the components easier, the OK-VISE team has selected some basic sets to enable an easy start with the Blank system. In the pictures below you can see the solutions done with each set.



### SK-Z7

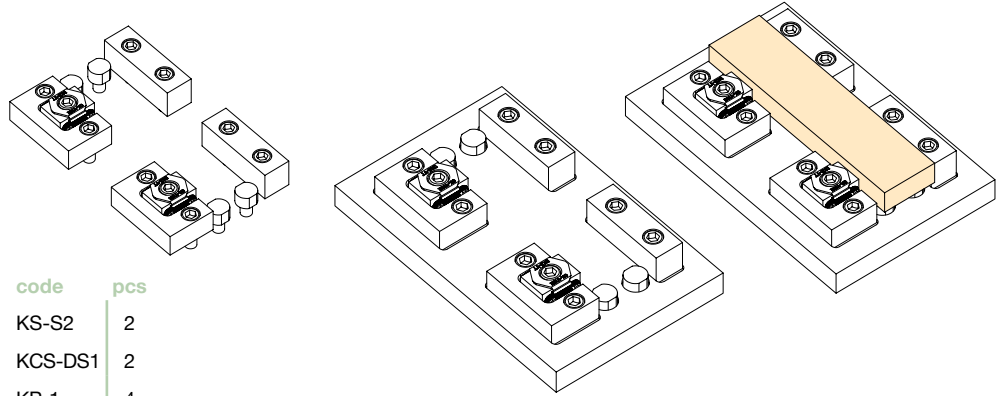

code	pcs
KS-S2	2
KCS-DS1	2
KP-1	4

### SK-Z2

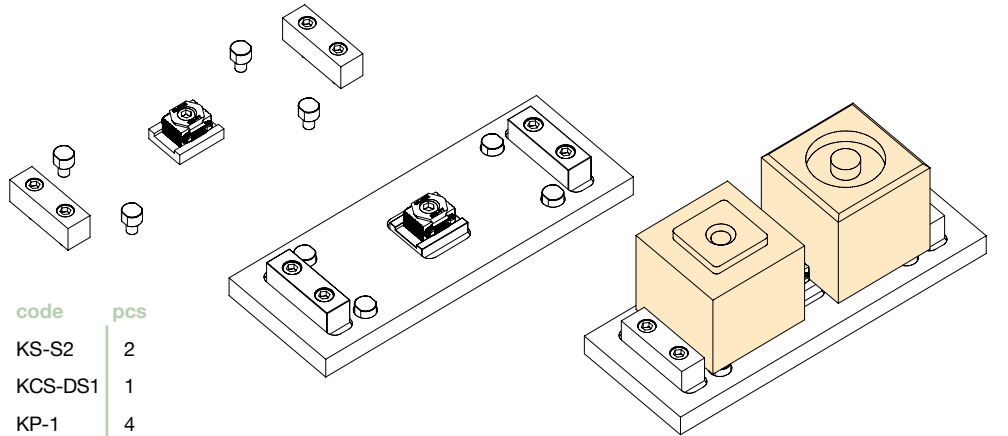

code	pcs
KS-S2	2
KCS-DS1	1
KP-1	4

### SK-Z8

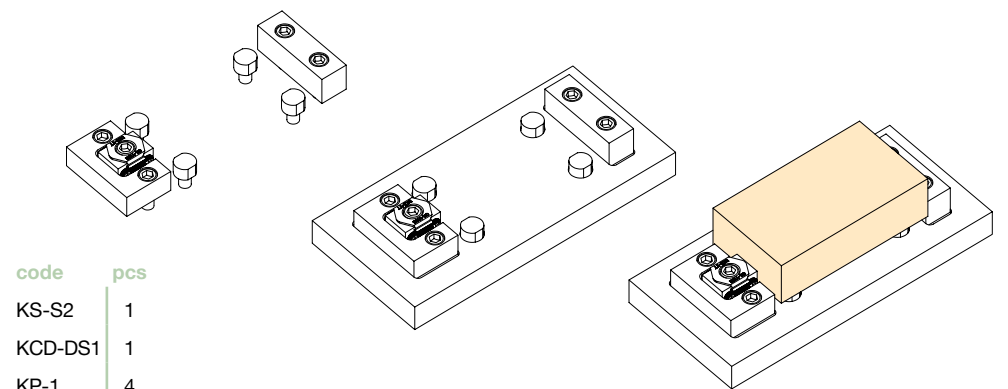

code	pcs
KS-S2	1
KCD-DS1	1
KP-1	4

### SK-Z4

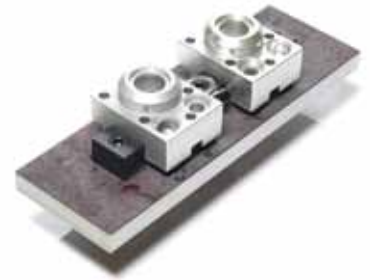
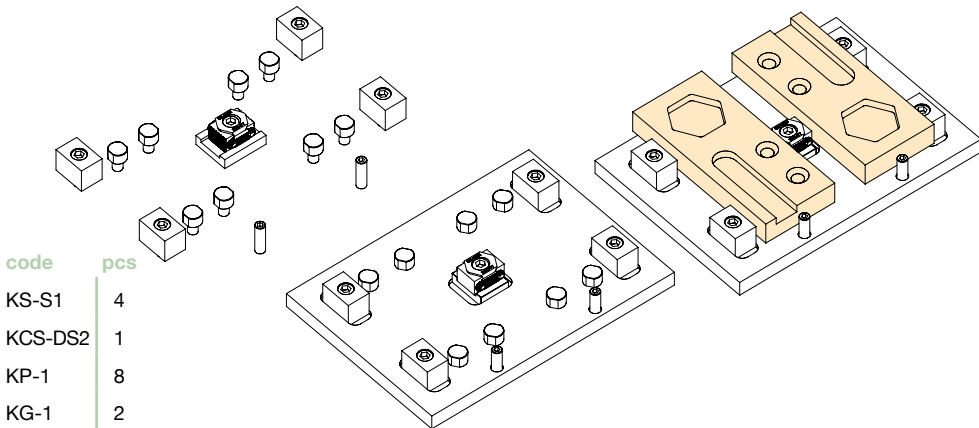

### SK-Z6

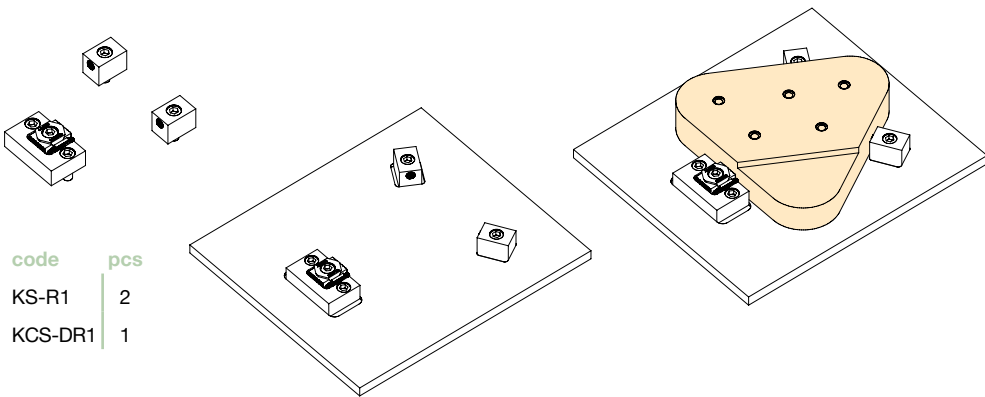

## OK-VISE HYDRAULIC ACTUATOR

Hydraulic pressure ( $p$ ) is first converted to downwards force ( $B$ ) and using the wedge clamp clamping force ( $F$ ) is created in two directions. Just like in manual clamping, a stopper is needed on both sides of the clamp.

The simplest way of creating a hydraulic fixture is to use a hydraulic actuator in single acting installation. In some applications double acting installation may be needed. Then, the push force is higher than the pull force.

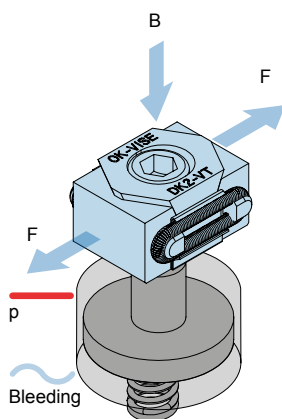

SINGLE ACTING

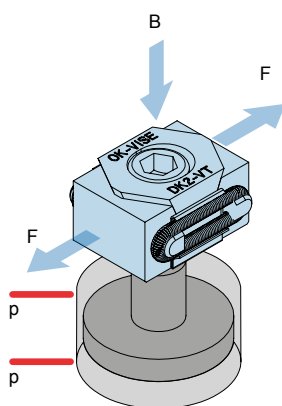

DOUBLE ACTING

## OK-VISE METHOD OF HYDRAULIC CLAMPING

As the original inventor of the wedge-operated low-profile clamp, OK-VISE has introduced hydraulic actuators that are optimised to utilize the well-known properties of the OK-VISE clamp: extreme clamping force in a small space combined with the accuracy of the clamping force.

As integral part of the OK-VISE Fixturing Concept, hydraulic actuators can be used to build truly modular fixtures.

Hydraulic clamping can be used in combination with

- Automated or manual workpiece loading
- Vertical or horizontal machining centers and 5-axis machines
- A continuous pressure source or a hydraulic connection that is uncoupled after loading

## APPLICATIONS



**Multi-Rail RM units + hydraulics.** Continuous hydraulic connection with horizontal machining center.

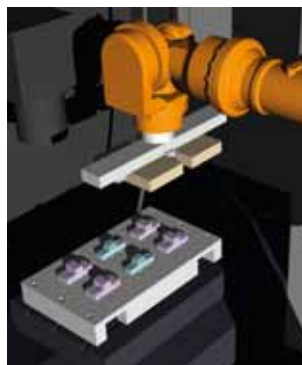

**Grid System + hydraulics.** Continuous hydraulic connection with vertical machining center.



**Blank system + hydraulics.** Hydraulic connection is uncoupled after loading. Used in FMS systems.

## RETRO-FIT OPTION

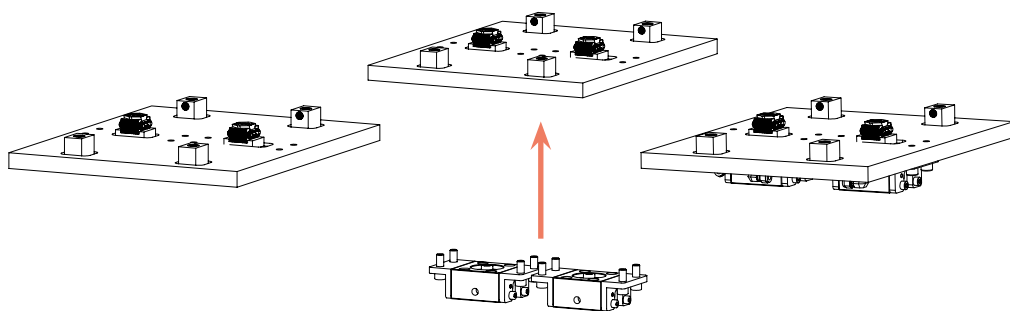

When a manually operated fixture is designed in the proper way, OK-VISE hydraulic modules can also be installed afterwards in a simple manner. This is the easiest way to enter the world of automated clamping!



## BENEFITS OF HYDRAULIC CLAMPING

Compared to manual clamping, a system using hydraulic clamping has a consistent clamping force on the workpiece, clamping is faster and enables automated (“robotic”) loading of workpieces.

Compared to other hydraulic systems on the market, the OK-VISE module

- Based on the world renown wedge clamp
- Wedge design prevents compression of hydraulic oil preventing vibration
- Creates clamping force with a pull stroke
- Return stroke is performed by spring or hydraulics
- Uses HA-Series actuator designed for 350 bar pressure, which results in compact size



**HA-2S1**  
56x80 mm  
H=46 mm

**HA-1S1**  
90x90 mm  
H=50–69 mm

## SOME BASIC COMPONENTS



## INSTALLATION

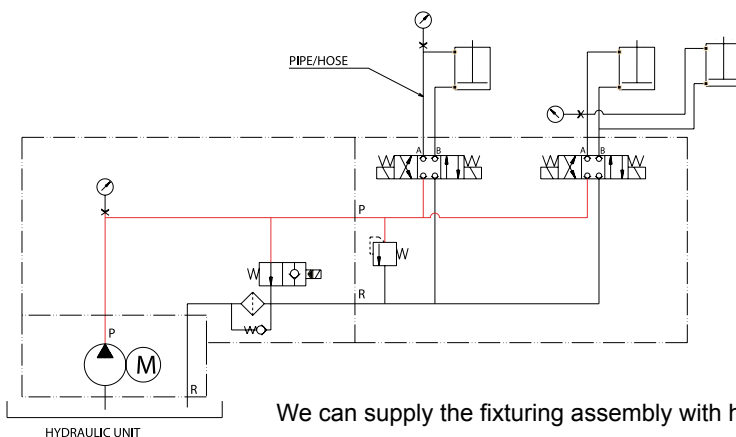

We can supply the fixturing assembly with hydraulic actuators. Our partners worldwide take care of hydraulic installations. Some sample connection diagrams are available from [support@ok-vise.com](mailto:support@ok-vise.com)

More info: [ok-vise.com/hydraulic-clamping/](http://ok-vise.com/hydraulic-clamping/)



## SUB-PLATES

The sub-plate concept can be used to build fixtures with all machine types and platforms.

When a fixture is built on a plate as a single unit, changing the fixtures set up is faster than in the case of installing fixture components on a machine table or a tooling block.

In most cases it makes better sense to clamp the workpieces to the fixture outside the machine “off-line” and then transfer the fixture with the workpieces to the machine. In this way the output of the machine can be easily maximized.

Tooling blocks and the Rotary Pallet System ( RPS ) from OK-VISE are examples of systems where the sub-plate concept has been successfully used.

Sub-plates can be used to carry dedicated or generic-purpose fixtures.

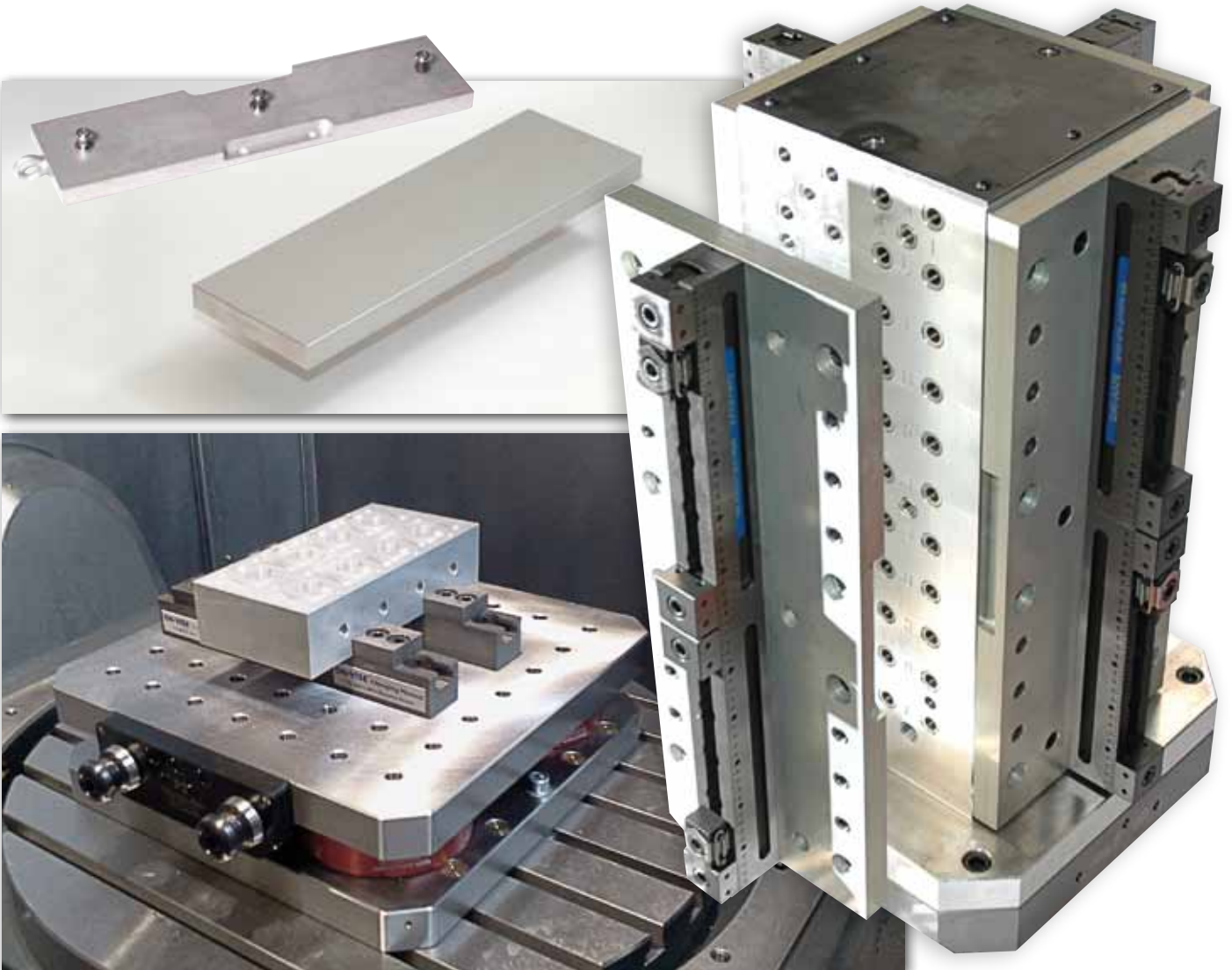
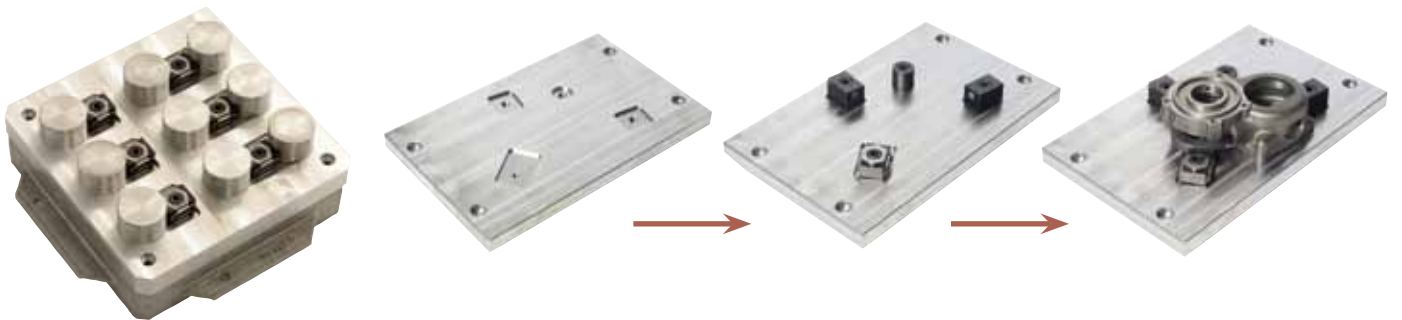

# PLATFORMS

In addition to fixturing components, we offer workholding platforms such as tooling blocks, zero-point positioning systems (OK-LOCK) and trunnion units (RPS).

Our fixturing components fit all platforms, but the most common platforms are based on T-slots, grid patterns or a simple blank surface that will be machined to produce a fixture.

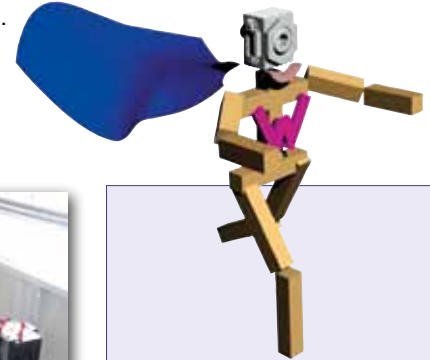

## WEDGEMAN SELECTION TOOL

OK-VISE has designed an easy selection tool to help customers select the most suitable fixturing system for their needs.

First, choose a workpiece design from the examples given.

Next choose the platform you are using, and the most suitable component sets are shown. To compare the sets and to obtain more detailed information, follow the links to the OK-VISE product webpages.

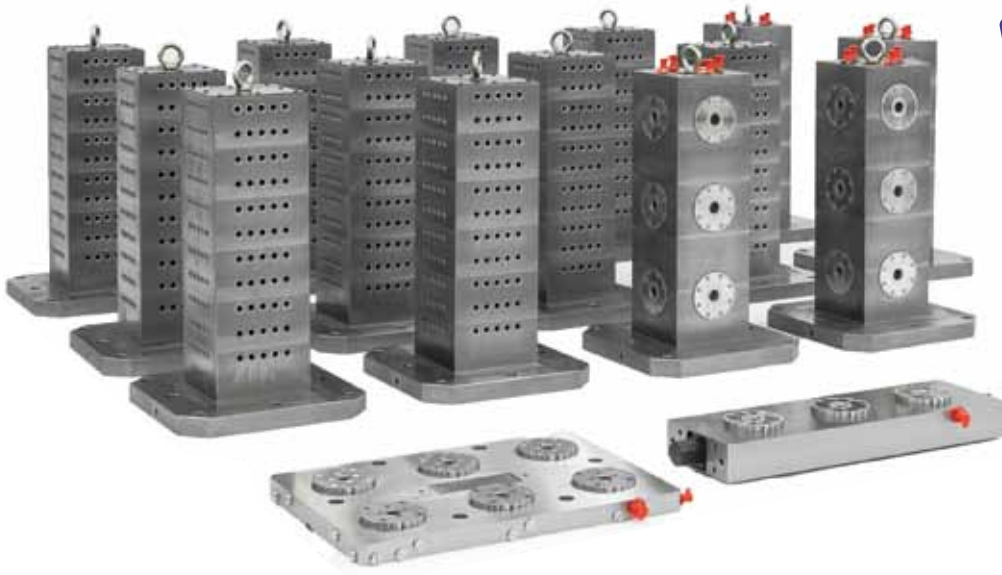

# BASED ON CLAMPING METHOD OK-VISE FIXTURING CONCEPT

**10** YEAR  
WARRANTY

## GENERIC FIXTURING CONCEPTS

Multi-Rail RM System

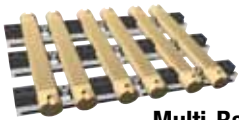

Multi-Rail RH System

Grid Fixturing System



Combo-Rail



## LOW-PROFILE CLAMPS



**OK-VISE**<sup>®</sup>  
Clamping Method

ALL PLATFORMS, ALL WORKPIECES

## COMPONENTS FOR DEDICATED FIXTURING

Blank Fixturing System

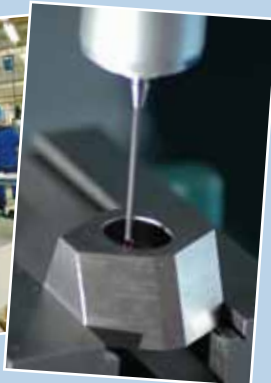
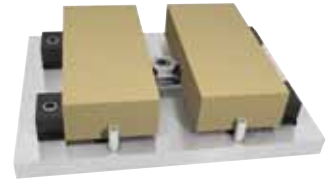

OK-VISE fixturing components are known worldwide as core components of any modern workholding system. In the machining industry the OK-VISE name stands for ultimate quality.

Kytola Instruments Oy, a sister company to OK-Vise Oy, has a long and proven history of designing and manufacturing high quality precision instruments. [www.kytola.com](http://www.kytola.com)

Our products are available through a global distribution network and can reach even the most distant places within a few working days. A wide selection of information as well as the latest updates about our products are easily obtained from our website at: [www.ok-vise.com](http://www.ok-vise.com)

MANUFACTURER

DISTRIBUTOR

**OK-VISE**<sup>®</sup>

OK-Vise Oy, P.O.Box 5  
40951 Muurame, Finland  
Tel. +358 20 7790 699, Fax +358 14 631 419  
Technical questions: [support@ok-vise.com](mailto:support@ok-vise.com)  
[www.ok-vise.com](http://www.ok-vise.com)