

LIFTING SYSTEMS



STAND BEHIND YOUR WORK™



550+ SERVICE CENTERS NATIONWIDE

INDUSTRY-LEADING WARRANTIES

EXPERT TECHNICAL SERVICE



**DURABILITY TO
HANDLE THE JOB.
SAFETY TO PROTECT
YOUR INVESTMENT.**

LIFTING SYSTEMS

For more than 50 years, industrial tradesmen have relied on JET® to provide the safest and most durable chain and lever hoists for their lifting, pulling and holding applications. If you are looking for a hand operated chain hoist or a best-in-class lever hoist equipped with overload protection and shipyard hooks, JET has the right product to fit the toughest jobs in the most demanding environments.

CONTENTS

WHY CHOOSE JET LIFTING SYSTEMS	4-5	CABLE & GRIP PULLERS	46-47
L-100 HAND CHAIN HOIST SERIES	6-13	VOLT ELECTRIC HOISTS	48-53
S90 HAND CHAIN HOIST SERIES	14-21	ELECTRIC HOISTS	54-56
JLH LEVER HOIST SERIES	22-29	ELECTRIC HOIST ACCESSORIES	57
JLP-A LEVER HOIST SERIES	30-37	JACKS	58-61
MANUAL HOIST ACCESSORIES	38-41	SCISSOR LIFT TABLES	62-63
WEB STRAP HOIST	42-45		

WHY CHOOSE JET LIFTING SYSTEMS

WITH INDUSTRY-LEADING TECHNOLOGY AND SAFETY FEATURES, JET'S FULL LINE OF MANUAL AND ELECTRIC HOISTS ARE THE SAFEST AND MOST DURABLE HOISTS ENGINEERED FOR THE TOUGHEST JOBS.



THE JET[®] ADVANTAGE

From the moment you start working with JET, it's easy to see what makes us different. At every level of our organization, we're end-user focused. We're constantly striving to provide a better experience for anyone who uses JET products. We have wide offerings of products to cover the many jobsite challenges our users face. With an eye toward innovative products, safety and tool durability, we are committed to our customers now and for years to come.



HERITAGE

Hoists were the first products JET launched over 50 years ago. Since then JET has sustained a commanding presence in the industry as one of the premiere hoist manufacturers in the U.S. market.



INNOVATION

JET's extensive research and development results in industry-leading, innovative products that focus on safety and durability.



PHILOSOPHY

Since 1958, our philosophy has been, and always will be, to satisfy the needs and demands of our customers.



DEPENDABILITY

We are confident of every JET hoist we manufacture. To prove it, we back every hand chain and lever hoist that bears the JET name with a Lifetime Warranty. The JET lifetime warranty is for the product's lifetime with no end date. This warranty covers manufacturer's defects only and does not cover misuse, abuse, accidents, negligence, wear and tear, improper repair or alterations, etc. Buy with confidence knowing JET will stand behind your work.

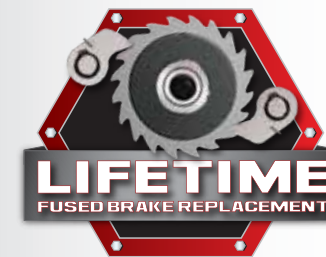

FUSED BRAKE REPLACEMENT

JET's revolutionary single-piece brake design fuses three components into one of the safest and most durable brake system in the market. JET is so confident of this design; it is backed by a lifetime replacement warranty.



2-YEAR WARRANTY

JET Electric Hoists and Electric Hoist Accessories are covered by a 2-year warranty against any manufacturing defects in workmanship or materials.

IN-DEPTH LOOK AT L-100 SAFETY AND DURABILITY



SAFETY COMES STANDARD

JET® lifting systems are comprised of the safest and most durable chain and lever hoists or lifting, pulling, and holding applications. If you're looking for safety, dependability, and durability, choose JET Lifting Systems.

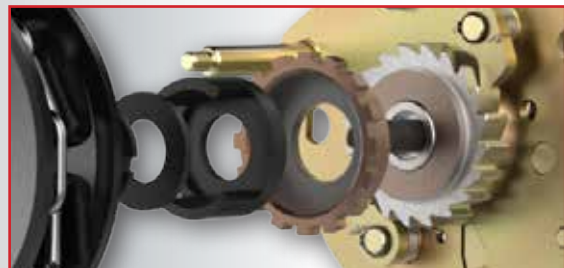

OVERLOAD PROTECTION

L-100 Overload protected models feature a slip clutch style overload protection that prevents lifting or pulling of damaging loads beyond the rated capacity of the hoist. Once triggered, the overload protection can be reset on site.



FUSED BRAKES

Nearly 10 years ago, JET lead the way on safety innovation by introducing the first single-piece brake that fuses three components into one for the most durable brake system in the market.



DOUBLE PAWLS

JET L-100 Hand Chain Hoists from 1/4 to 20 tons utilize the Weston Style, double pawl brake design that splits the load to opposite sides of the ratchet gear for greater load security.

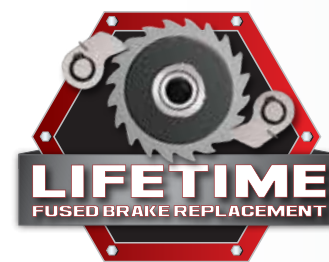

LIFETIME BRAKE WARRANTY

The JET single-piece fused brake design is a revolution in hoist technology. JET is so confident of this design, it's backed by a lifetime replacement warranty.

DURABILITY GUARANTEED

All JET® hoists are engineered to meet strict tolerances and are constructed with quality materials to ensure they last. JET stands behind these products with industry-leading warranties and support.



HEAT-TREATED LOAD PLATES

The heat-treated, case hardened and corrosive resistant coated internal parts extend the life of the hoist in the harshest environments.



GRADE 100 PLATED LOAD CHAIN

The corrosive resistant plated Grade 100 load chain is a smaller, more compact link that is 20% stronger than Grade 80 load chain.



CAST LATCHES

Secured with Allen screws and lock nuts, the cast-steel safety latches are more durable than stamped steel latches and will not bend out of compliance with lifting regulations.



LIFETIME WARRANTY

JET backs every manual hand chain and lever hoist with a lifetime warranty against any manufacturer defects. Buy with confidence knowing JET will stand behind your work.

L-100 SERIES SAFETY COMES STANDARD



FUSED BRAKE DESIGN

JET's revolutionary single-piece brake design fuses three components into one of the safest and most durable brake system in the market. JET is so confident of this design; it is backed by a lifetime replacement warranty.

DUAL PAWL WESTON BRAKE

Weston style double ratchet pawl brake design splits the load to opposite sides of the ratchet gear for greater load security.

OVERLOAD PROTECTION MODELS

Overload protection models feature a slip clutch style overload protection that prevents lifting or pulling of damaging loads beyond the rated capacity of the hoist. Once triggered, the overload protection can be reset on site.

ALLOY STEEL HOOKS

The alloy steel hooks rotate 360 degrees for easy rigging applications, and slowly stretch to indicate an overload situation.

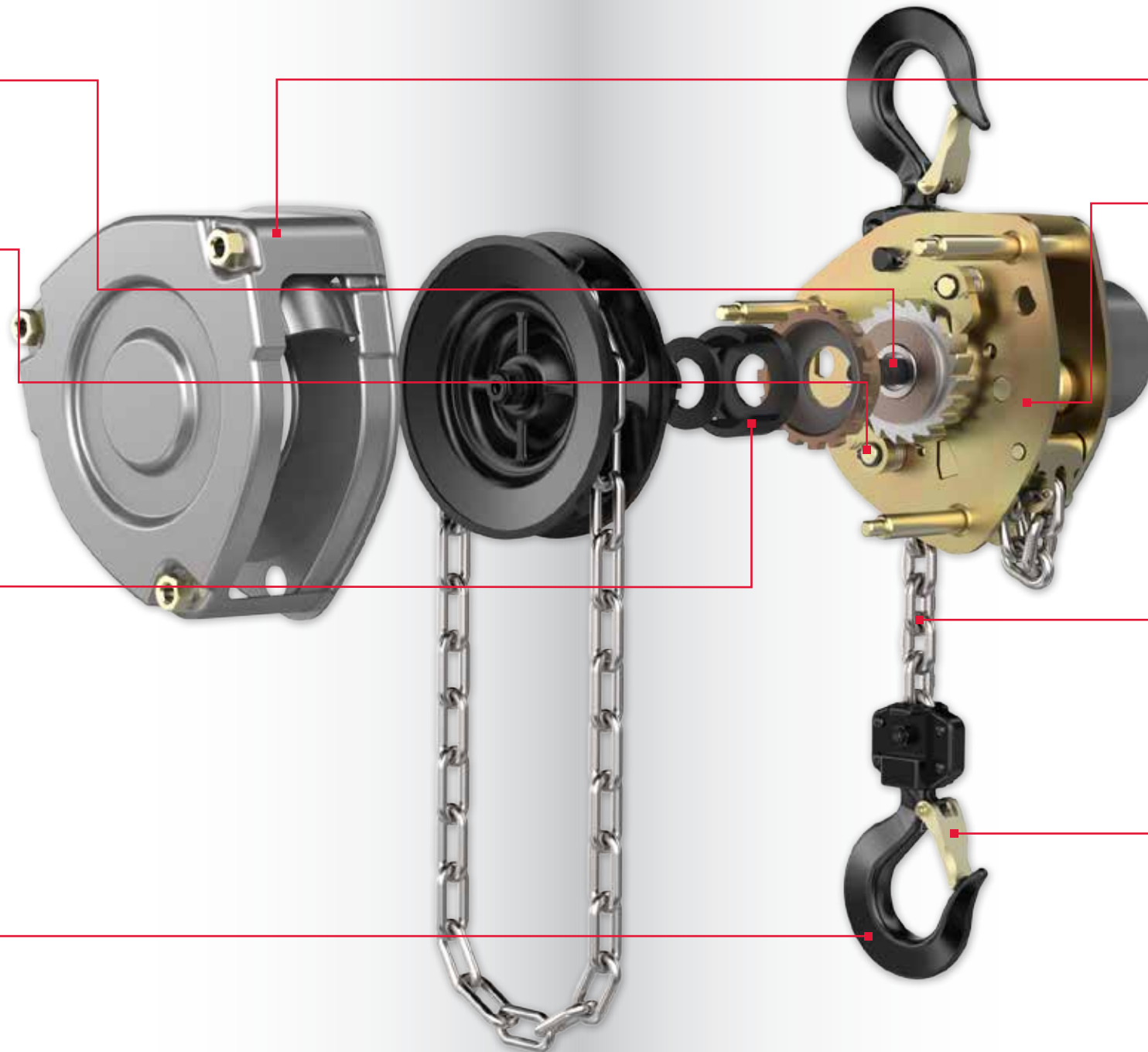

ALL STEEL CONSTRUCTION

The impact resistant, all steel construction of JET manual hoists increases durability, lengthening tool life.

HEAT-TREATED LOAD PLATES

Intended for the harshest environments, the heat treated load plates and case hardened corrosive resistant internal parts extend the life of the hoist.

GRADE 100 PLATED LOAD CHAIN

The corrosive resistant plated Grade 100 load chain is a smaller, more compact link that is 20% stronger than Grade 80 load chain.

CAST-STEEL SAFETY LATCHES

Secured with Allen screws and lock nuts, the cast-steel safety latches are more durable than stamped steel latches and will not bend out of compliance with lifting regulations.

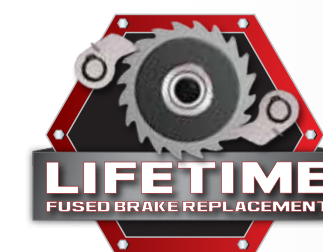

L-100 SERIES HAND CHAIN HOIST

L-100 SERIES HAND CHAIN HOISTS STANDARD MODELS

SAFETY

- Backed by a lifetime replacement warranty, JET's revolutionary single-piece brake design fuses the three components into the safest brake system in the market
- Overload protected models feature a slip clutch style overload protection that prevents lifting or pulling of damaging loads beyond the rated capacity of the hoist
- Once triggered, the overload protection can be reset on site
- Weston style double ratchet pawl brake design splits the load to opposite sides of the ratchet gear for greater load security
- Industrial rated alloy steel hooks rotate 360 degrees for easy rigging and slowly stretch to indicate an overload situation

DURABILITY

- Grade 100, corrosive resistant plated load chain is a smaller, more compact link that is 20% stronger than Grade 80 load chain
- Secured with Allen screws and lock nuts, the cast-steel safety latches are more durable than stamped steel latches and will not bend out of compliance with lifting regulations
- Intended for the harshest environments, the heat treated load plates and case hardened corrosive resistant internal parts extend the life of the hoist
- Double sealed ball bearings support the load sheave to increase efficiency and promote smooth operation
- Impact resistant all steel construction for added durability and protection
- The lightweight and smaller body design are ideal for confined areas and low headroom applications

STANDARDS

- This product complies with ANSI / ASME B30.16 and HST-2 Standards
- Load tested to 125% of capacity with certificate



FUSED BRAKES

Nearly 10 years ago, JET lead the way on safety innovation by introducing the first single-piece brake that fuses three components into one for the most durable brake system in the market.

HEAT-TREATED LOAD PLATES

The heat-treated, case hardened and corrosive resistant coated internal parts extend the life of the hoist in the harshest environments.

STOCK NO.	MODEL NO.	CAPACITY (TONS)	CAPACITY (LBS.)	STANDARD LIFT (FT.)	HEADROOM (IN.)	HAND CHAIN TO LIFT LOAD 1 FT. (FT.)	LBS. OF PULL TO LIFT CAPACITY	WEIGHT (LBS.)	REPLACEMENT PARTS	REPLACEMENT PART STOCK NO.
1/4-TON STANDARD MODELS										
100210	L-100-25-10	1/4	550	10	9-13/16	18	42	10	Top Hook	L100-25-1
100215	L-100-25-15	1/4	550	15	9-13/16	18	42	12	Bottom Hook	L100-25-5
100220	L-100-25-20	1/4	550	20	9-13/16	18	42	14	Safety Latch Kit	L100-25-2
100230	L-100-25-30	1/4	550	30	9-13/16	18	42	16		
1/2-TON STANDARD MODELS										
106210	L-100-50-10	1/2	1,100	10	11-1/4	25	53	22	Top Hook	L100-50-1
105215	L-100-50-15	1/2	1,100	15	11-1/4	25	53	27	Bottom Hook	L100-50-5
106220	L-100-50-20	1/2	1,100	20	11-1/4	25	53	31	Safety Latch Kit	L100-50-2
105230	L-100-50-30	1/2	1,100	30	11-1/4	25	53	36		
1-TON STANDARD MODELS										
101210	L-100-100-10	1	2,200	10	11-5/8	43	64	27	Top Hook	L100-100-1
101215	L-100-100-15	1	2,200	15	11-5/8	43	64	34	Bottom Hook	L100-100-5
104220	L-100-100-20	1	2,200	20	11-5/8	43	64	40	Safety Latch Kit	L100-100-2
101230	L-100-100-30	1	2,200	30	11-5/8	43	64	51		
1-1/2 TON STANDARD MODELS										
101610	L-100-150-10	1-1/2	3,300	10	13-3/4	57	77	35	Top Hook	L100-150-1
101615	L-100-150-15	1-1/2	3,300	15	13-3/4	57	77	41	Bottom Hook	L100-150-5
101620	L-100-150-20	1-1/2	3,300	20	13-3/4	57	77	48	Safety Latch Kit	L100-152-2
101630	L-100-150-30	1-1/2	3,300	30	13-3/4	57	77	65		
2-TON STANDARD MODELS										
102210	L-100-200-10	2	4,400	10	14-3/4	70	79	44	Top Hook	L100-200-1
102215	L-100-200-15	2	4,400	15	14-3/4	70	79	50	Bottom Hook	L100-200-5
102220	L-100-200-20	2	4,400	20	14-3/4	70	79	59	Safety Latch Kit	L100-200-2
102230	L-100-200-30	2	4,400	30	14-3/4	70	79	75		
3-TON STANDARD MODELS										
103210	L-100-300-10	3	6,600	10	20-1/16	114	79	53	Top Hook	L100-300-1
103215	L-100-300-15	3	6,600	15	20-1/16	114	79	66	Bottom Hook	L100-300-5
103220	L-100-300-20	3	6,600	20	20-1/16	114	79	74	Safety Latch Kit	L100-300-2
103230	L-100-300-30	3	6,600	30	20-1/16	114	79	94		
5-TON STANDARD MODELS										
105510	L-100-500-10	5	11,000	10	23-5/8	196	75	90	Top Hook	L100-500-1
105515	L-100-500-15	5	11,000	15	23-5/8	196	75	105	Bottom Hook	L100-500-5
105520	L-100-500-20	5	11,000	20	23-5/8	196	75	130	Safety Latch Kit	L100-500-2
105530	L-100-500-30	5	11,000	30	23-5/8	196	75	165		
10-TON STANDARD MODELS										
101010	L-100-1000-10	10	22,000	10	29-5/16	396	79	155	Top Hook	L100-1000-1
201015	L-100-1000-15	10	22,000	15	29-5/16	396	79	181	Bottom Hook	L100-1000-5
101020	L-100-1000-20	10	22,000	20	29-5/16	396	79	206	Safety Latch Kit	L100-1000-2
101030	L-100-1000-30	10	22,000	30	29-5/16	396	79	257		
15-TON STANDARD MODELS										
101111	L-100-1500-10	15	33,000	10	33-7/8	594	80 x 2	288	Top Hook	L100-1500-1
101115	L-100-1500-15	15	33,000	15	33-7/8	594	80 x 2	327	Bottom Hook	L100-1500-5
101110	L-100-1500-20	15	33,000	20	33-7/8	594	80 x 2	365	Safety Latch Kit	L100-1500-2
101130	L-100-1500-30	15	33,000	30	33-7/8	594	80 x 2	442		
20-TON STANDARD MODELS										
102011	L-100-2000-10	20	44,000	10	34-1/4	396 x 2	80 x 2	384	Top Hook	L100-2000-1
102015	L-100-2000-15	20	44,000	15	34-1/4	396 x 2	80 x 2	437	Bottom Hook	L100-2000-5
102010	L-100-2000-20	20	44,000	20	34-1/4	396 x 2	80 x 2	490	Safety Latch Kit	L100-2000-2
102030	L-100-2000-30	20	44,000	30	34-1/4	396 x 2	80 x 2	597		

L-100 SERIES HAND CHAIN HOISTS OVERLOAD PROTECTION MODELS

TECHNICAL SPECIFICATIONS AND COMPARISON WORKSHEET

STOCK NO.	MODEL NO.	CAPACITY (TONS)	CAPACITY (LBS.)	STANDARD LIFT (FT.)	HEADROOM (IN.)	REQUIRED HAND CHAIN TO LIFT CAPACITY (FT.)	LBS. OF PULL TO LIFT CAPACITY	WEIGHT (LBS.)	REPLACEMENT PARTS	REPLACEMENT PART STOCK NO.
1/4-TON OVERLOAD PROTECTION MODELS										
101200	L-100-25WO-10	1/4	550	10	9-13/16	18	42	10	Top Hook	L100-25-1
101225	L-100-25WO-15	1/4	550	15	9-13/16	18	42	12	Bottom Hook	L100-25-2
101250	L-100-25WO-20	1/4	550	20	9-13/16	18	42	14	Safety Latch Kit	L100-25-2
101223	L-100-25WO-30	1/4	550	30	9-13/16	18	42	16		
1/2-TON OVERLOAD PROTECTION MODELS										
104100	L-100-50WO-10	1/2	1,100	10	11-1/4	25	53	24	Top Hook	L100-50-1
205115	L-100-50WO-15	1/2	1,100	15	11-1/4	25	53	29	Bottom Hook	L100-50-5
205120	L-100-50WO-20	1/2	1,100	20	11-1/4	25	53	34	Safety Latch Kit	L100-50-2
205130	L-100-50WO-30	1/2	1,100	30	11-1/4	25	53	44		
1-TON OVERLOAD PROTECTION MODELS										
102100	L-100-100WO-10	1	2,200	10	11-5/8	43	64	27	Top Hook	L100-100-1
203115	L-100-100WO-15	1	2,200	15	11-5/8	43	64	33	Bottom Hook	L100-100-5
203120	L-100-100WO-20	1	2,200	20	11-5/8	43	64	39	Safety Latch Kit	L100-100-2
203130	L-100-100WO-30	1	2,200	30	11-5/8	43	64	51		
1-1/2 TON OVERLOAD PROTECTION MODELS										
101100	L-100-150WO-10	1-1/2	3,300	10	13-3/4	57	77	34	Top Hook	L100-150-1
201115	L-100-150WO-15	1-1/2	3,300	15	13-3/4	57	77	41	Bottom Hook	L100-150-5
201120	L-100-150WO-20	1-1/2	3,300	20	13-3/4	57	77	48	Safety Latch Kit	L100-150-2
201130	L-100-150WO-30	1-1/2	3,300	30	13-3/4	57	77	62		
2-TON OVERLOAD PROTECTION MODELS										
105100	L-100-200WO-10	2	4,400	10	14-3/4	70	79	44	Top Hook	L100-200-1
206115	L-100-200WO-15	2	4,400	15	14-3/4	70	79	52	Bottom Hook	L100-200-5
206121	L-100-200WO-20	2	4,400	20	14-3/4	70	79	59	Safety Latch Kit	L100-200-2
206130	L-100-200WO-30	2	4,400	30	14-3/4	70	79	75		
3-TON OVERLOAD PROTECTION MODELS										
106100	L-100-300WO-10	3	6,600	10	20-1/16	114	79	53	Top Hook	L100-300-1
207115	L-100-300WO-15	3	6,600	15	20-1/16	114	79	64	Bottom Hook	L100-300-5
207120	L-100-300WO-20	3	6,600	20	20-1/16	114	79	74	Safety Latch Kit	L100-300-2
207130	L-100-300WO-30	3	6,600	30	20-1/16	114	79	95		
5-TON OVERLOAD PROTECTION MODELS										
107100	L-100-500WO-10	5	11,000	10	23-5/8	198	75	90	Top Hook	L100-500-1
208115	L-100-500WO-15	5	11,000	15	23-5/8	198	75	105	Bottom Hook	L100-500-5
208120	L-100-500WO-20	5	11,000	20	23-5/8	198	75	120	Safety Latch Kit	L100-500-21
208130	L-100-500WO-30	5	11,000	30	23-5/8	198	75	149		
10-TON OVERLOAD PROTECTION MODELS										
108100	L-100-1000WO-10	10	22,000	10	29-5/16	396	79	174	Top Hook	L100-1000-1
209115	L-100-1000WO-15	10	22,000	15	29-5/16	396	79	200	Bottom Hook	L100-1000-5
209120	L-100-1000WO-20	10	22,000	20	29-5/16	396	79	227	Safety Latch Kit	L100-1000-2
209130	L-100-1000WO-30	10	22,000	30	29-5/16	396	79	279		
15-TON OVERLOAD PROTECTION MODELS										
109110	L-100-1500WO-10	15	33,000	10	33-7/8	594	80 x 2	381	Top Hook	L100-1500-1
109115	L-100-1500WO-15	15	33,000	15	33-7/8	594	80 x 2	400	Bottom Hook	L100-1500-5
109100	L-100-1500WO-20	15	33,000	20	33-7/8	594	80 x 2	425	Safety Latch Kit	L100-1500-2
109130	L-100-1500WO-30	15	33,000	30	33-7/8	594	80 x 2	450		
20-TON OVERLOAD PROTECTION MODELS										
102020	L-100-2000WO-10	20	44,000	10	34-1/4	396 x 2	80 x 2	381	Top Hook	L100-2000-1
108015	L-100-2000WO-15	20	44,000	15	34-1/4	396 x 2	80 x 2	400	Bottom Hook	L100-2000-5
102000	L-100-2000WO-20	20	44,000	20	34-1/4	396 x 2	80 x 2	425	Safety Latch Kit	L100-2000-2
108030	L-100-2000WO-30	20	44,000	30	34-1/4	396 x 2	80 x 2	450		

* CUSTOM LIFTS AVAILABLE IN ALL CAPACITIES IN 5 FT INCREMENTS

COMPETITIVE COMPARISON

How Do We Stack Up- use the chart provided to see how the JET L-100 Series Hand Chain Hoist stacks up against the competition.

Model No.	L-100								
Headroom (In.)									
Overload Protection	✓								
One-Piece Fused Brake	✓								
Weston Style Double Pawls	✓								
Sealed Ball Bearing Support	✓								
Grade 100 Load Chain	✓								
Cast Steel Safety Latches	✓								
Lifetime Brake Replacement	✓								
Lifetime Warranty	✓								

L-100 TECHNICAL INFORMATION

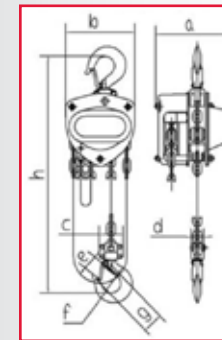

HOIST CAPACITY	"a"	"b"	"c"	"d"	"e"	"f"	"g"	"h"
1/4 Ton	3-3/4	4-5/16	1-3/16	13/16	1-1/16	1-1/4	1-3/8	9-13/16
1/2 Ton	5/18	5-1/2	1-11/16	1	1-1/16	1-1/4	1-3/8	11-1/4
1 Ton	6-3/8	6-5/16	2	1-3/16	1-5/16	1-9/16	1-3/4	11-5/8
1-1/2 Ton	6-11/16	7-3/16	2-1/2	1-5/16	1-5/16	1-5/8	1-7/8	13-3/4
2 Ton	7-1/4	8	2-1/2	1-5/16	1-7/16	1-13/16	2-1/16	14-3/4
3 Ton	6-11/16	9-1/4	4-1/16	2-1/16	1-11/16	2-1/16	2-7/16	20-1/16
5 Ton	7-9/16	11-1/8	5-1/4	2-1/2	2	2-3/8	3-1/8	23-5/8
10 Ton	7-9/16	14-3/16	10-3/8	3-3/4	2-1/2	3-3/8	-	29-15/16
15 Ton	7-7/8	19-3/8	4-5/16	6-1/8	3-1/8	3-15/16	-	33-7/8
20 Ton	9-1/16	25-13/16	11-1/4	4-13/16	3-1/4	4-15/16	-	34-1/4

L-100 CHAIN LIMITS INFORMATION



HOIST CAPACITY	5 LINKS NORMAL (IN.)	5 LINKS LIMIT REPLACE IF ≥
1/4 Ton	2.36	2.43
1/2 Ton	2.95	3.04
1 Ton	3.74	3.85
1-1/2 Ton	4.13	3.25
2 Ton	4.72	4.86
3 Ton	4.13	4.25
5 Ton	5.31	5.47
10 Ton	5.31	5.47
15 Ton	5.31	5.47
20 Ton	5.31	5.47

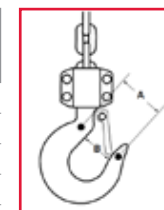

HOIST CAPACITY	"A" DIMENSION NORMAL (IN.)	"A" DIMENSION REPLACE IF ≥	"B" DIMENSION NORMAL (IN.)	"B" DIMENSION REPLACE IF ≥
1/4 Ton	1.39	1.47	-	-
1/2 Ton	1.36	1.44	-	-
1 Ton	1.77	1.88	-	-
1-1/2 Ton	1.86	1.97	-	-
2 Ton	2.05	2.17	-	-
3 Ton	1.45	2.60	-	-
5 Ton	3.06	3.24	-	-
10 Ton	-	-	2.52	2.67
15 Ton	-	-	3.15	3.34
20 Ton	-	-	3.23	3.42

IN-DEPTH LOOK AT S-90 SAFETY AND DURABILITY



SAFETY COMES STANDARD

JET® lifting systems are comprised of the safest and most durable chain and lever hoists or lifting, pulling and holding applications. If you're looking for safety, dependability, and durability, choose JET Lifting Systems.



DOUBLE PAWLS

JET S90 Hand Chain Hoists from 1/2 to 10 tons utilize the Weston Style, double pawl brake design that splits the load to opposite sides of the ratchet gear for greater load security.



CAST LATCHES

Secured with Allen screws and lock nuts, the cast-steel safety latches are more durable than stamped steel latches and will not bend out of compliance with lifting regulations.

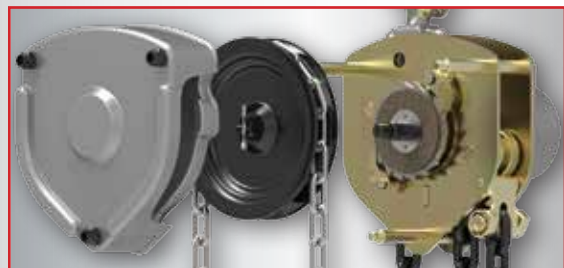

ALL STEEL CONSTRUCTION

The impact resistant, all steel construction of JET manual hoists increases durability, lengthening tool life.

DURABILITY GUARANTEED

All JET® hoists are engineered to meet strict tolerances and are constructed with quality materials to ensure they last. JET stands behind these products with industry-leading warranties and support.



HEAT-TREATED LOAD PLATES

The heat-treated, case hardened and corrosive resistant coated internal parts extend the life of the hoist in the harshest environments.



ALLOY STEEL HOOKS

The alloy steel hooks rotate 360 degrees for easy rigging applications, and slowly stretch to indicate an overload situation.



LIFETIME WARRANTY

JET backs every manual hand chain and lever hoist with a lifetime warranty against any manufacturer defect. Buy with confidence knowing JET will stand behind your work.

S90 SERIES SAFETY COMES STANDARD



DUAL PAWL WESTON BRAKE

The dual pawl Weston style brake is a double ratchet pawl design that increases load safety. The dual pawl system is what physically stops and holds the load when the lifting and lowering operation stops.

CAST-STEEL SAFETY LATCHES

The cast-steel latches are more durable than stamped steel latches and will not bend out of compliance with lifting regulations.

ALLOY STEEL HOOKS

The alloy steel hooks rotate 360 degrees for easy rigging applications, and slowly stretch to indicate an overload situation.



ALL STEEL CONSTRUCTION

The impact resistant, all steel construction of JET manual hoist increases durability, lengthening tool life.

HEAT-TREATED LOAD PLATES

The heat-treated, case hardened and corrosive resistant coated internal parts extend the life of the hoist in the harshest environments.

LOAD CHAIN

Grade 80 black oxide coated load chain for added durability.



S90 SERIES HAND CHAIN HOISTS



SAFETY

- The Weston style double ratchet pawl brake design splits the load to opposite sides of the ratchet gear for greater load security and increased safety
- Alloy steel hooks rotate 360 degrees for easy rigging applications, and slowly stretch to indicate an overload situation

DURABILITY

- Grade 80 black oxide coated load chain for added durability
- Intended for the harshest environments, the heat treated load plates and case hardened corrosive resistant internal parts extend the life of the hoist
- **NEW!** Secured with Allen screws and lock nuts, the cast-steel safety latches will not bend out of compliance with lifting regulations
- Needle bearings support the load sheave to increase efficiency and promote smooth operation
- Impact resistant all steel construction for added durability and protection
- Smaller body and lightweight design for low headroom applications and use in confined areas

STANDARDS

- This product complies with ANSI / ASME B30.16 and HST-2 Standards
- Load tested to 125% of capacity with certificate



DOUBLE PAWLS

JET S90 Hand Chain Hoists from 1/2 to 10 tons utilize the Weston Style, double pawl brake design that splits the load to opposite sides of the ratchet gear for greater load security.



CAST LATCHES

Secured with Allen screws and lock nuts, the cast-steel safety latches are more durable than stamped steel latches and will not bend out of compliance with lifting regulations.

STOCK NO.	MODEL NO.	CAPACITY (TONS)	CAPACITY (LBS.)	STANDARD LIFT (FT.)	HEADROOM (IN.)	HAND CHAIN TO LIFT LOAD 1 FT. (FT.)	LBS. OF PULL TO LIFT CAPACITY	WEIGHT (LBS.)	REPLACEMENT PART	REPLACEMENT PART STOCK NO.
1/2-TON STANDARD MODELS										
101900	S90-50-10	1/2	1,100	10	11	32	58	26	Top Hook	S90-050-1
101901	S90-50-15	1/2	1,100	15	11	32	58	31	Bottom Hook	S90-050-4
101902	S90-50-20	1/2	1,100	20	11	32	58	36	Safety Latch kit	S90-050-2
101903	S90-50-30	1/2	1,100	30	11	32	58	45		
1-TON STANDARD MODELS										
101910	S90-100-10	1	2,200	10	12	53	60	35	Top Hook	S90-100-1
101911	S90-100-15	1	2,200	15	12	53	60	41	Bottom Hook	S90-100-4
101912	S90-100-20	1	2,200	20	12	53	60	47	Safety Latch kit	S90-100-2
101913	S90-100-30	1	2,200	30	12	53	60	58		
1-1/2 TON STANDARD MODELS										
101920	S90-150-10	1-1/2	3,300	10	14-1/2	57	84	50	Top Hook	S90-150-1
101921	S90-150-15	1-1/2	3,300	15	14-1/2	57	84	58	Bottom Hook	S90-150-4
101922	S90-150-20	1-1/2	3,300	20	14-1/2	57	84	66	Safety Latch kit	S90-150-2
101923	S90-150-30	1-1/2	3,300	30	14-1/2	57	84	81		
2-TON STANDARD MODELS										
101930	S90-200-10	2	4,400	10	17-1/2	71	91	52	Top Hook	S90-200-1
101931	S90-200-15	2	4,400	15	17-1/2	71	91	60	Bottom Hook	S90-200-4
101932	S90-200-20	2	4,400	20	17-1/2	71	91	68	Safety Latch kit	S90-200-2
101933	S90-200-30	2	4,400	30	17-1/2	71	91	83		
3-TON STANDARD MODELS										
101940	S90-300-10	3	6,600	10	20-1/2	115	87	78	Top Hook	S90-300-1
101941	S90-300-15	3	6,600	15	20-1/2	115	87	90	Bottom Hook	S90-300-4
101942	S90-300-20	3	6,600	20	20-1/2	115	87	103	Safety Latch kit	S90-300-2
101943	S90-300-30	3	6,600	30	20-1/2	115	87	128		
5-TON STANDARD MODELS										
101950	S90-500-10	5	11,000	10	23-3/5	178	90	123	Top Hook	S90-500-1
101951	S90-500-15	5	11,000	15	23-3/5	178	90	140	Bottom Hook	S90-500-4
101952	S90-500-20	5	11,000	20	23-3/5	178	90	158	Safety Latch kit	S90-500-2
101953	S90-500-30	5	11,000	30	23-3/5	178	90	194		
10-TON STANDARD MODELS										
101960	S90-1000-10	10	22,000	10	30	357	96	220	Top Hook	S90-1000-1
101961	S90-1000-15	10	22,000	15	30	357	96	252	Bottom Hook	S90-1000-4
101962	S90-1000-20	10	22,000	20	30	357	96	284	Safety Latch kit	S90-1000-2
101963	S90-1000-30	10	22,000	30	30	357	96	349		

*CUSTOM LIFTS AVAILABLE IN ALL CAPACITIES IN 5 FT INCREMENTS

TECHNICAL SPECIFICATIONS AND COMPARISON WORKSHEET

COMPETITIVE COMPARISON

How Do We Stack Up- use the chart provided to see how the JET S90 Series Hand Chain Hoist stacks up against the competition.

Model No.	S90			
Headroom (In.)				
Weston Style Double Pawls	✓			
Needle Bearing Design	✓			
Cast Steel Safety Latches	✓			
Lifetime Warranty	✓			

S90 BRAKE DISC INFORMATION

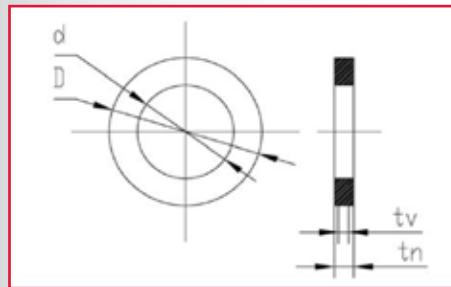

HOIST CAPACITY	OUTER DIAMETER (IN.)	INNER DIAMETER (IN.)	BRAKE PAD THICKNESS (IN.)	REPLACE DISCS IF ≤ (IN.)
1/2 Ton	1.54	0.87	0.10	0.08
1 Ton	2.36	1.20	0.08	0.06
1-1/2 Ton	2.68	1.40	0.08	0.06
2 Ton	2.68	1.40	0.08	0.06
3 Ton	2.68	1.40	0.08	0.06
5 Ton	3.35	1.79	0.10	0.08
10 Ton	3.35	1.79	0.10	0.08

S90 TECHNICAL INFORMATION

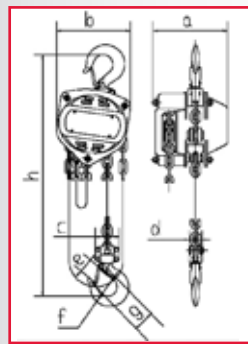

HOIST CAPACITY	"a"	"b"	"c"	"d"	"e"	"f"	"g"	"h"
1/2 Ton	5.0	5.1	1.7	1.0	1.1	1.3	1.4	11.0
1 Ton	5.3	6.1	2.0	1.2	1.3	1.6	1.8	12.0
1-1/2 Ton	6.0	6.8	2.5	1.3	1.3	1.7	1.9	14.5
2 Ton	6.2	7.3	2.5	1.3	1.5	1.8	2.0	17.5
3 Ton	6.2	9.3	4.0	2.2	1.7	2.0	2.5	20.5
5 Ton	7.1	10.3	5.0	3.0	2.0	2.4	3.0	23.6
10 Ton	7.1	14.4	10.0	3.9	2.5	3.3	-	30.0

S90 CHAIN LIMITS INFORMATION

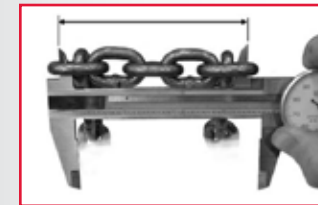

HOIST CAPACITY	5 LINKS NORMAL (IN.)	5 LINKS LIMIT REPLACE IF ≥
1/2 Ton	2.95	3.04
1 Ton	3.54	3.65
1-1/2 Ton	4.72	4.86
2 Ton	4.72	4.86
3 Ton	4.72	4.86
5 Ton	5.91	6.07
10 Ton	5.91	6.07

S90 HOOK LIMITS INFORMATION

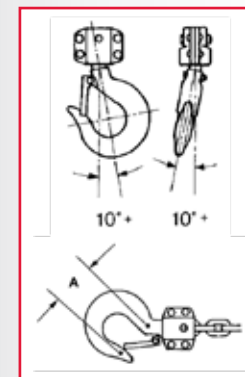

HOIST CAPACITY	"A" DIMENSION NORMAL (IN.)	"A" DIMENSION REPLACE IF ≥
1/2 Ton	1.36	1.44
1 Ton	1.77	1.88
1-1/2 Ton	1.86	1.97
2 Ton	2.05	2.17
3 Ton	2.45	2.60
5 Ton	3.06	3.24
10 Ton	2.52	2.67

AN IN-DEPTH LOOK AT JLH SAFETY AND DURABILITY



SAFETY COMES STANDARD

JET® lifting systems are comprised of the safest and most durable chain and lever hoists or lifting, pulling and holding applications. If you're looking for safety, dependability, and durability, choose JET Lifting Systems.



OVERLOAD PROTECTION

JET's JLH Series lever hoists come standard with the slip clutch overload protection. This design prevents lifting or pulling damaging loads beyond the rated capacity of the hoist and is easily reset in the field by lowering the load.



NEW HANDLE & GRIP DESIGN

New on the JLH Series lever hoists, is a progressive offset handle design that allows for extra clearance between the operator's hand and load chain. The redesigned ergonomic grip allows for greater operator control and increased comfort.

DURABILITY GUARANTEED

All JET® hoists are engineered to meet strict tolerances and are constructed with quality materials to ensure they last. JET stands behind these products with industry-leading warranties and support.



FUSED BRAKES

Nearly 10 years ago, JET lead the way on safety innovation by introducing the first single-piece brake that fuses three components into one for the most durable brake system in the market.



DOUBLE PAWLS

JET Lever hoists from 1/4 to 9 tons utilize the Weston Style, double pawl brake design that splits the load to opposite sides of the ratchet gear for greater load security.



FREE CHAINING

JET's improved easy free chain design is a two-step, no load, free chaining system. The system permits quicker hoist positioning and take up of slack chain. And it is engineered not to free chain under load. The two-step free chain function is engaged and disengaged by twisting the hand wheel and aligning the marks.

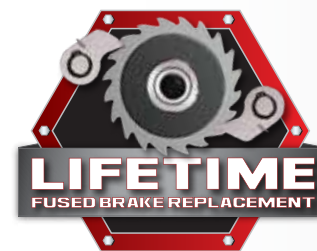

LIFETIME BRAKE WARRANTY

The JET single-piece fused brake design is a revolution in hoist technology. JET is so confident of this design, it's backed by a lifetime replacement warranty.



CAST LATCHES

Secured with Allen screws and lock nuts, the cast-steel safety latches are more durable than stamped steel latches and will not bend out of compliance with lifting regulations.



LIFETIME WARRANTY

JET backs every manual hand chain and lever hoist with a lifetime warranty against any manufacturer defect. Buy with confidence knowing JET will stand behind your work.

JLH SERIES SAFETY COMES STANDARD



JLH SERIES LEVER HOISTS

JET's JLH Series lever hoists come standard with the slip clutch overload protection. The innovative design adds additional safety to your job while maximizing production time. Once triggered the overload protection can be easily reset in the field to reduce downtime.

OVERLOAD PROTECTION

JET's JLH Series lever hoists come standard with the slip clutch overload protection. This design prevents lifting or pulling damaging loads beyond the rated capacity of the hoist and is easily reset in the field by lowering the load.

IMPROVED FREE CHAINING

JET's improved easy free chain design is a two-step, no load, free chaining system. The system permits quicker hoist positioning and take up of slack chain. And it is engineered not to free chain under load.

HANDLE DESIGN

The advanced offset handle design allows for extra clearance between the operator's hand and the load chain.

IMPROVED GRIP DESIGN

The improved ergonomic grip allows for greater operator control and increased comfort.



FUSED BRAKE DESIGN

JET's revolutionary single-piece brake design fuses three components into the safest and most durable brake system in the market. JET is so confident of this design; it is backed by a lifetime replacement warranty.

HEAT-TREATED LOAD PLATES

Intended for the harshest environments, the heat treated load plates and case hardened corrosive resistant internal parts extend the life of the hoist.

CAST-STEEL SAFETY LATCHES

Secured with Allen screws and lock nuts, the cast-steel safety latches are more durable than stamped steel latches and will not bend out of compliance with lifting regulations.

ALLOY STEEL HOOKS

The alloy steel hooks rotate 360 degrees for easy rigging applications, and slowly stretch to indicate an overload situation.

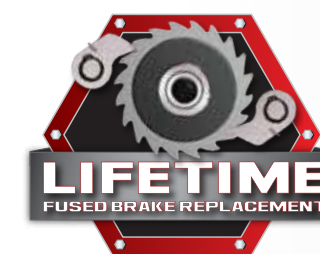

JLH SERIES LEVER HOISTS

JLH SERIES LEVER HOISTS MODELS

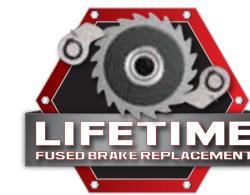

SAFETY

- Backed by a lifetime replacement warranty, JET's revolutionary single-piece brake design fuses the three components into the safest brake system in the market
- **NEW!** All JLH-Series Lever Hoists come with slip clutch style overload protection that prevents lifting or pulling damaging loads beyond the rated capacity of the hoist and when triggered, the overload protection can be reset on site
- Weston style double ratchet pawl brake design splits the load to opposite sides of the ratchet gear for greater load security
- **NEW!** JET's improved easy free chain design is a two-step, no load, free chaining system. The system permits quicker hoist positioning and take up of slack chain. And it is engineered not to free chain under load
- **NEW!** The advanced offset handle design allows for extra clearance between the operator's hand and the load chain
- Industrial rated alloy steel hooks rotate 360 degrees for easy rigging and slowly stretch to indicate an overload situation

DURABILITY

- Grade 100, corrosive resistant plated load chain is a smaller, more compact link that is 20% stronger than Grade 80 load chain
- Secured with Allen screws and lock nuts, the cast-steel safety latches are more durable than stamped steel latches and will not bend out of compliance with lifting regulations
- Intended for the harshest environments, the heat treated load plates and case hardened corrosive resistant internal parts extend the life of the hoist
- Caged needle bearings support the load sheave to increase efficiency and promote smooth operation
- Impact resistant all steel construction for added durability and protection
- The lightweight design with shorter handle and smaller body are ideal for confined areas and low headroom applications

STANDARDS

- This product complies with ANSI / ASME B30.21 and HST-3 Standards
- Load tested to 125% of capacity with certificate



SHIPYARD HOOK MODELS

Optional blunt tip, point loading hooks virtually eliminate stretched hooks, reducing downtime for maintenance and repair.



IMPROVED FREE CHAINING

JET's improved easy free chain design is a two-step, no load, free chaining system. The system permits quicker hoist positioning and take up of slack chain.

STOCK NO.	MODEL NO.	CAPACITY (TONS)	CAPACITY (LBS.)	STANDARD LIFT (FT.)	HEADROOM (IN.)	LOAD CHAIN (DIA/MM)	LEVER LENGTH (IN.)	POUNDS OF PULL TO LIFT CAPACITY	WEIGHT (LBS.)	REPLACEMENT PARTS	REPLACEMENT PART STOCK NO.
1/4-TON JLH SERIES LEVER HOISTS											
181205	JLH-25-5	1/4	500	5	7-9/10	3.2 x 9	5-3/4	45	3-1/2	Top Hook	JLH25-1G
181210	JLH-25-10	1/4	500	10	7-9/10	3.2 x 9	5-3/4	45	4-2/5	Bottom Hook	JLH25-4G
181215	JLH-25-15	1/4	500	15	7-9/10	3.2 x 9	5-3/4	45	5-2/7	Safety Latch Kit	JLH25-2
1/2-TON JLH SERIES LEVER HOISTS											
181505	JLH-50-5	1/2	1,000	5	9-7/10	4.3 x 12	6-3/10	54	5-1/2	Top Hook	JLH50-1G
181510	JLH-50-10	1/2	1,000	10	9-7/10	4.3 x 12	6-3/10	54	7	Bottom Hook	JLH50-4G
181515	JLH-50-15	1/2	1,000	15	9-7/10	4.3 x 12	6-3/10	54	8-3/5	Safety Latch Kit	JLH50-2
3/4-TON JLH SERIES LEVER HOISTS WITH OVERLOAD PROTECTION											
376100	JLH-75WO-5	3/4	1,760	5	11	5.6 x 15.7	10-1/4	64	13	Top Hook	JLH80-40-1
376101	JLH-75WO-10	3/4	1,760	10	11	5.6 x 15.7	10-1/4	64	15	Bottom Hook	JLH80-38-1
376102	JLH-75WO-15	3/4	1,760	15	11	5.6 x 15.7	10-1/4	64	17	Safety Latch Kit	JLH80-37-1
376103	JLH-75WO-20	3/4	1,760	20	11	5.6 x 15.7	10-1/4	64	20		
1-TON JLH SERIES LEVER HOISTS WITH OVERLOAD PROTECTION											
376200	JLH-100WO-5	1	2,200	5	11-4/5	5.6 x 15.7	10-1/4	79	13	Top Hook	JLH100-40-1
376201	JLH-100WO-10	1	2,200	10	11-4/5	5.6 x 15.7	10-1/4	79	16	Bottom Hook	JLH100-38-1
376202	JLH-100WO-15	1	2,200	15	11-4/5	5.6 x 15.7	10-1/4	79	18	Safety Latch Kit	JLH100-37-1
376203	JLH-100WO-20	1	2,200	20	11-4/5	5.6 x 15.7	10-1/4	79	21		
1-1/2-TON JLH SERIES LEVER HOISTS WITH OVERLOAD PROTECTION											
376300	JLH-150WO-5	1-1/2	3,520	5	13-1/5	7.1 x 19.9	10-1/4	75	18	Top Hook	JLH160-40-1
376301	JLH-150WO-10	1-1/2	3,520	10	13-1/5	7.1 x 19.9	10-1/4	75	22	Bottom Hook	JLH160-38-1
376302	JLH-150WO-15	1-1/2	3,520	15	13-1/5	7.1 x 19.9	10-1/4	75	26	Safety Latch Kit	JLH160-37-1
376303	JLH-150WO-20	1-1/2	3,520	20	13-1/5	7.1 x 19.9	10-1/4	75	30		
2-1/2-TON JLH SERIES LEVER HOISTS WITH OVERLOAD PROTECTION											
376400	JLH-250WO-5	2-1/2	5,500	5	14-3/4	8.8 x 24.6	10-1/4	82	25	Top Hook	JLH250-40-1
376401	JLH-250WO-10	2-1/2	5,500	10	14-3/4	8.8 x 24.6	10-1/4	82	31	Bottom Hook	JLH250-38-1
376402	JLH-250WO-15	2-1/2	5,500	15	14-3/4	8.8 x 24.6	10-1/4	82	36	Safety Latch Kit	JLH250-37-1
376403	JLH-250WO-20	2-1/2	5,500	20	14-3/4	8.8 x 24.6	10-1/4	82	42		
3-TON JLH SERIES LEVER HOISTS WITH OVERLOAD PROTECTION											
376500	JLH-300WO-5	3	7,040	5	15-5/9	10 x 28	16-1/3	84	33	Top Hook	JLH320-40-1
376501	JLH-300WO-10	3	7,040	10	15-5/9	10 x 28	16-1/3	84	41	Bottom Hook	JLH320-38-1
376502	JLH-300WO-15	3	7,040	15	15-5/9	10 x 28	16-1/3	84	48	Safety Latch Kit	JLH320-37-1
376503	JLH-300WO-20	3	7,040	20	15-5/9	10 x 28	16-1/3	84	56		
6-TON JLH SERIES LEVER HOISTS WITH OVERLOAD PROTECTION											
376600	JLH-600WO-5	6	13,860	5	21-1/4	10 x 28	16-1/3	84	58	Top Hook	JLH630-40-1
376601	JLH-600WO-10	6	13,860	10	21-1/4	10 x 28	16-1/3	84	73	Bottom Hook	JLH630-38-1
376602	JLH-600WO-15	6	13,860	15	21-1/4	10 x 28	16-1/3	84	88	Safety Latch Kit	JLH630-37-1
376603	JLH-600WO-20	6	13,860	20	21-1/4	10 x 28	16-1/3	84	103		
9-TON JLH SERIES LEVER HOISTS WITH OVERLOAD PROTECTION											
376700	JLH-900WO-5	9	19,800	5	26-4/5	10 x 28	16-1/3	88	95	Top Hook	JLH900-40-1
376701	JLH-900WO-10	9	19,800	10	26-4/5	10 x 28	16-1/3	88	118	Bottom Hook	JLH900-38-1
376702	JLH-900WO-15	9	19,800	15	26-4/5	10 x 28	16-1/3	88	140	Safety Latch Kit	JLH900-37-1
376703	JLH-900WO-20	9	19,800	20	26-4/5	10 x 28	16-1/3	88	163		

*CUSTOM LIFTS AVAILABLE IN ALL CAPACITIES IN 5 FT INCREMENTS

STOCK NO.	MODEL NO.	CAPACITY (TONS)	CAPACITY (LBS.)	STANDARD LIFT (FT.)	HEADROOM (IN.)	LOAD CHAIN (DIA/MM)	LEVER LENGTH (IN.)	POUNDS OF PULL TO LIFT CAPACITY	WEIGHT (LBS.)	REPLACEMENT PARTS	REPLACEMENT PART STOCK NO.
1-1/2-TON JLH SERIES LEVER HOISTS WITH SHIP YARD HOOKS AND OVERLOAD PROTECTION											
376800	JLH-150-5PSH	1-1/2	3,520	5	13-1/5	7.1 x 19.9	10-1/4	75	18	Top Hook	JLH160-40PH-1
376801	JLH-150-10PSH	1-1/2	3,520	10	13-1/5	7.1 x 19.9	10-1/4	75	22	Bottom Hook	JLH160-38PH-1
376802	JLH-150-15PSH	1-1/2	3,520	15	13-1/5	7.1 x 19.9	10-1/4	75	26	Safety Latch Kit	JLH160-37-1PH
376803	JLH-150-20PSH	1-1/2	3,520	20	13-1/5	7.1 x 19.9	10-1/4	75	30		
3-TON JLH SERIES LEVER HOISTS WITH SHIP YARD HOOKS AND OVERLOAD PROTECTION											
376900	JLH-300-5PSH	3	7,040	5	15-5/9	10 x 28	16-1/3	84	33	Top Hook	JLH320-40PH-1
376901	JLH-300-10PSH	3	7,040	10	15-5/9	10 x 28	16-1/3	84	41	Bottom Hook	JLH320-38PH-1
376902	JLH-300-15PSH	3	7,040	15	15-5/9	10 x 28	16-1/3	84	48	Safety Latch Kit	JLH320-37-1PH
376903	JLH-300-20PSH	3	7,040	20	15-5/9	10 x 28	16-1/3	84	56		

JLH SERIES COMPACT LEVER HOIST



SAFETY

- Weston style double ratchet pawl brake design splits the load to opposite sides of the ratchet gear for greater load security
- Industrial rated alloy steel hooks rotate 360 degrees for easy rigging and slowly stretch to indicate an overload situation

DURABILITY

- Grade 100, corrosive resistant plated load chain is a smaller, more compact link that is 20% stronger than Grade 80 load chain
- Secured with Allen screws and lock nuts, the cast-steel safety latches are more durable than stamped steel latches and will not bend out of compliance with lifting regulations
- Durable, impact resistant, aluminum alloy housings makes the JLH Compact lever hoist one of the lightest hoists on the market
- Five gear drive train requires less force to lift or secure a load
- Intended for the harshest environments, the heat treated load plates and case hardened corrosive resistant internal parts extend the life of the hoist
- Every JLH Compact Lever Hoist includes as standard equipment a rugged vinyl pouch with belt loops and carrying strap
- Folds down to 7" for portability around the jobsite

STANDARDS

- This product complies with ANSI / ASME B30.21 and HST-3 Standards
- Load tested to 125% of capacity with certificate



STOCK NO.	MODEL NO.	CAPACITY (TONS)	CAPACITY (LBS.)	STANDARD LIFT (FT.)	HEADROOM (IN.)	NUMBER OF FALLS	LOAD CHAIN (DIA/ MM)	LEVER LENGTH (IN.)	POUNDS OF PULL TO LIFT CAPACITY	LIFT PER FULL TURN OF LEVER (IN.)	WEIGHT (LBS.)
1/4-TON COMPACT LEVER HOIST											
181205	JLH-25-5	1/4	500	5	7-9/10	1	3.2 x 9	5-3/4	45	3/7	3-1/2
181210	JLH-25-10	1/4	500	10	7-9/10	1	3.2 x 9	5-3/4	45	3/7	4
181215	JLH-25-15	1/4	500	15	7-9/10	1	3.2 x 9	5-3/4	45	3/7	5
1/2-TON COMPACT LEVER HOIST											
181505	JLH-50-5	1/2	1,000	5	9-7/10	1	4.3 x 12	6-3/10	54	1/3	5-1/2
181510	JLH-50-10	1/2	1,000	10	9-7/10	1	4.3 x 12	6-3/10	54	1/3	7
181515	JLH-50-15	1/2	1,000	15	9-7/10	1	4.3 x 12	6-3/10	54	1/3	8

TECHNICAL SPECIFICATIONS AND COMPARISON WORKSHEET

COMPETITIVE COMPARISON

How Do We Stack Up- use the chart provided to see how the JET JLH Series Lever Hoist stacks up against the competition.

Model No.	JLH				
Headroom (In.)					
Overload Protection	✓				
One-Piece Fused Brake	✓				
Easy 2-Step Double Pawls	✓				
Weston Style Double Pawls	✓				
Caged Needle Bearing Support	✓				
Patented Handle Design	✓				
Grade 100 Load Chain	✓				
Cast Steel Safety Latches	✓				
Lifetime Brake Replacement	✓				
Lifetime Warranty	✓				

JLH TECHNICAL INFORMATION

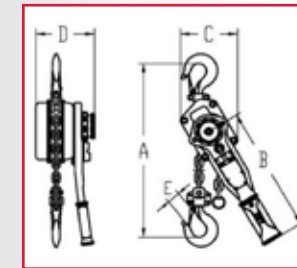

MODEL NO.	"A"	"B"	"C"	"D"	"E"
JLH-75	11.02	9.6	4.69	5.37	0.93
JLH-100	11.81	9.6	4.69	5.67	1.14
JLH-150	13.19	10.4	4.69	6.26	1.26
JLH-250	14.75	10.4	5.9	6.81	1.44
JLH-300	15.55	16.3	6.26	7.48	1.54
JLH-600	21.26	16.3	8.54	7.48	1.97
JLH-900	26.79	16.3	16.3	11.73	2.13

JLH CHAIN LIMITS INFORMATION



HOIST CAPACITY	"A" DIMENSION NORMAL (IN.)	"A" DIMENSION REPLACE IF ≥
3/4 Ton	1.65	1.73
1 Ton	1.96	2.07
1-1/2 Ton	2.06	2.17
2-1/2 Ton	2.36	2.48
3 Ton	2.47	2.60
6 Ton	3.33	3.50
9 Ton	3.33	3.50

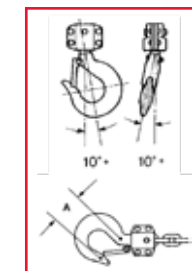

HOIST CAPACITY	5 LINKS NORMAL (IN.)	5 LINKS LIMIT REPLACE IF ≥
3/4 Ton	3.11	3.20
1 Ton	3.11	3.20
1-1/2 Ton	3.94	4.05
2-1/2 Ton	4.88	5.00
3 Ton	5.55	5.71
6 Ton	5.55	5.71
9 Ton	5.55	5.71

AN IN-DEPTH LOOK AT THE JLP-A SAFETY AND DURABILITY



SAFETY COMES STANDARD

Committed to delivering the simplest and most efficient safety solutions, JET is proud to introduce the new JLP-A Series of lever hoists. Designed to create a safer work environment, the JLP-A is the right choice for your light to medium-duty industrial applications.



BRAKE WEAR INDICATOR

JET's advanced brake wear indicator provides visual indication of when it is time to replace worn friction disks so routine maintenance and downtime are scheduled.



FREE CHAINING

JET's improved easy free chain design is a two-step, no load, free chaining system. The system permits quicker hoist positioning and take up of slack chain. And it is engineered not to free chain under load. The two-step free chain function is engaged and disengaged by twisting the hand wheel and aligning the marks.



NEW GRIP DESIGN

New on the JLP-A Series lever hoists is a redesigned ergonomic grip that is secured lever arm providing greater operator control and increased comfort.

DURABILITY GUARANTEED

All JET® hoists are engineered to meet strict tolerances and are constructed with quality materials to ensure they last. JET stands behind these products with industry-leading warranties and support.



DOUBLE PAWLS

JET Lever hoists from 1/4 to 6 tons utilize the Weston Style, double pawl brake design that splits the load to opposite sides of the ratchet gear for additional safety on the job by enhancing load security.



CAST LATCHES

Secured with Allen screws and lock nuts, the cast-steel safety latches are more durable than stamped steel latches and will not bend out of compliance with lifting regulations.



LIFETIME WARRANTY

JET backs every manual hand chain and lever hoist with a lifetime warranty against any manufacturer defect. Buy with confidence knowing JET will stand behind your work.

JLP-A SERIES SAFETY COMES STANDARD



JLP-A SERIES LEVER HOISTS

JET's JLP-A Series lever hoist come standard with the new brake wear indicator. This technology adds additional safety to the job by providing a visual indication when the brake discs need replacing.

BRAKE WEAR INDICATOR

NEW! JET's advanced brake wear indicator provides visual indication of when it is time to replace worn friction disks so routine maintenance and downtime are scheduled.

IMPROVED FREE CHAINING

JET's improved easy free chain design is a two-step, no load, free chaining system. The system permits quicker hoist positioning and take up of slack chain. And it is engineered not to free chain under load.

ALL STEEL CONSTRUCTION

The impact resistant, all steel construction of JET manual hoists increases durability, lengthening tool life.

IMPROVED GRIP DESIGN

Improved ergonomic grip that is secured to the lever arm provides greater operator control and increased comfort.



DUAL PAWL WESTON BRAKE

The Weston Style, double pawl brake design that splits the load to opposite sides of the ratchet gear for additional safety on the job by enhancing load security.

LOAD CHAIN

Grade 80 black oxide coated load chain for added durability.

CAST-STEEL SAFETY LATCHES

Secured with Allen screws and lock nuts, the cast-steel safety latches are more durable than stamped steel latches and will not bend out of compliance with lifting regulations.

ALLOY STEEL HOOKS

The alloy steel hooks rotate 360 degrees for easy rigging applications, and slowly stretch to indicate an overload situation.



JLP-A SERIES LEVER HOISTS

JLP-A SERIES LEVER HOIST MODELS



SAFETY

- **NEW!** Innovative brake wear indicator provides a visual indication when the friction disks are worn and need replacing
- **NEW!** JET's improved easy free chain design is a two-step, no load, free chaining system. The system permits quicker hoist positioning and take up of slack chain. And it is engineered not to free chain under load.
- The Weston style double ratchet pawl brake design splits the load to opposite sides of the ratchet gear for greater load security and increased safety
- Alloy steel hooks rotate 360 degrees for easy rigging applications, and slowly stretch to indicate an overload situation
- **NEW!** Redesigned ergonomic grip allows for greater operator control and increased comfort

DURABILITY

- **NEW!** Secured with Allen screws and lock nuts, the cast-steel safety latches will not bend out of compliance with lifting regulations
- Grade 80 black oxide coated load chain for added durability
- Needle bearings support the load sheave to increase efficiency and promote smooth operation
- Impact resistant all steel construction for added durability and protection

STANDARDS

- This product complies with ANSI / ASME B30.21 and HST-3 Standards
- Load tested to 125% of capacity with certificate



SHIPYARD HOOK MODELS

The blunt tip of the point loading hooks virtually eliminates stretching to help reduce downtime for maintenance and repair.

BRAKE DISK WEAR INDICATOR

NEW! JLP-A Series lever hoists feature the Innovative brake wear indicator that provides visual indication of when it is time to replace worn friction disks so routine maintenance and downtime are scheduled.



STOCK NO.	MODEL NO.	CAPACITY (TONS)	CAPACITY (LBS.)	STANDARD LIFT (FT.)	HEADROOM (IN.)	LOAD CHAIN (DIA/MM)	LEVER LENGTH (IN.)	POUNDS OF PULL TO LIFT CAPACITY	WEIGHT (LBS.)	REPLACEMENT PARTS	REPLACEMENT PART STOCK NO.
1/4-TON JLP-A SERIES LEVER HOISTS											
287100	JLP-025A-5	1/4	500	5	8-1/4	4 x 12	6	60	4-5/9	Top Hook	JLP25A-26G
287101	JLP-025A-10	1/4	500	10	8-1/4	4 x 12	6	60	5-5/6	Bottom Hook	JLP25A-38G
287102	JLP-025A-15	1/4	500	15	8-1/4	4 x 12	6	60	7	Safety Latch Kit	JLP25A-27-1
1/2-TON JLP-A SERIES LEVER HOISTS											
287200	JLP-050A-5	1/2	1,000	5	10	4.3 x 12	8-1/2	86	5-1/6	Top Hook	JLP50A-26G
287201	JLP-050A-10	1/2	1,000	10	10	4.3 x 12	8-1/2	86	6-5/6	Bottom Hook	JLP50A-38G
287202	JLP-050A-15	1/2	1,000	15	10	4.3 x 12	8-1/2	86	8-1/3	Safety Latch Kit	JLP50A-27-1
3/4-TON JLP-A SERIES LEVER HOISTS											
287300	JLP-075A-5	3/4	1,650	5	12-4/5	6 x 18	11	31	14	Top Hook	JLP75A-41G
287301	JLP-075A-10	3/4	1,650	10	12-4/5	6 x 18	11	31	17	Bottom Hook	JLP75A-49G
287302	JLP-075A-15	3/4	1,650	15	12-4/5	6 x 18	11	31	19	Safety Latch Kit	JLP75A-63-1
287303	JLP-075A-20	3/4	1,650	20	12-4/5	6 x 18	11	31	22		
1-1/2-TON JLP-A SERIES LEVER HOISTS											
287400	JLP-150A-5	1-1/2	3,300	5	15	8 x 24	16-1/7	49	25	Top Hook	JLP150A-41G
287401	JLP-150A-10	1-1/2	3,300	10	15	8 x 24	16-1/7	49	30	Bottom Hook	JLP150A-49G
287402	JLP-150A-15	1-1/2	3,300	15	15	8 x 24	16-1/7	49	34	Safety Latch Kit	JLP150A-63-1
287403	JLP-150A-20	1-1/2	3,300	20	15	8 x 24	16-1/7	49	39		
3-TON JLP-A SERIES LEVER HOISTS											
287500	JLP-300A-5	3	6,600	5	18-8/9	10 x 30	16-1/7	71	43	Top Hook	JLP300A-41G
287501	JLP-300A-10	3	6,600	10	18-8/9	10 x 30	16-1/7	71	50	Bottom Hook	JLP300A-49G
287502	JLP-300A-15	3	6,600	15	18-8/9	10 x 30	16-1/7	71	57	Safety Latch Kit	JLP300A-63-1
287503	JLP-300A-20	3	6,600	20	18-8/9	10 x 30	16-1/7	71	65		
6-TON JLP-A SERIES LEVER HOISTS											
287600	JLP-600A-5	6	13,200	5	24-2/5	10 x 30	16-1/7	77	69	Top Hook	JLP600A-41G
287601	JLP-600A-10	6	13,200	10	24-2/5	10 x 30	16-1/7	77	84	Bottom Hook	JLP600A-49G
287602	JLP-600A-15	6	13,200	15	24-2/5	10 x 30	16-1/7	77	98	Safety Latch Kit	JLP600A-63-1
287603	JLP-600A-20	6	13,200	20	24-2/5	10 x 30	16-1/7	77	112		

STOCK NO.	MODEL NO.	CAPACITY (TONS)	CAPACITY (LBS.)	STANDARD LIFT (FT.)	HEADROOM (IN.)	LOAD CHAIN (DIA/MM)	LEVER LENGTH (IN.)	POUNDS OF PULL TO LIFT CAPACITY	WEIGHT (LBS.)	REPLACEMENT PARTS	REPLACEMENT PART STOCK NO.
1-1/2-TON JLP-A SERIES LEVER HOISTS WITH SHIP YARD HOOKS											
287700	JLP-150A-5SH	1-1/2	3,300	5	15	8 x 24	16-1/7	49	20	Top Hook	JLP150A-41PHG
287701	JLP-150A-10SH	1-1/2	3,300	10	15	8 x 24	16-1/7	49	27	Bottom Hook	JLP150A-49PHG
287702	JLP-150A-15SH	1-1/2	3,300	15	15	8 x 24	16-1/7	49	31	Safety Latch Kit	JLP150A-63-1PH
287703	JLP-150A-20SH	1-1/2	3,300	20	15	8 x 24	16-1/7	49	39		
3-TON JLP-A SERIES LEVER HOISTS WITH SHIP YARD HOOKS											
287800	JLP-300A-5SH	3	6,600	5	18-8/9	10 x 30	16-1/7	71	43	Top Hook	JLP300A-41PHG
287801	JLP-300A-10SH	3	6,600	10	18-8/9	10 x 30	16-1/7	71	50	Bottom Hook	JLP300A-49PHG
287802	JLP-300A-15SH	3	6,600	15	18-8/9	10 x 30	16-1/7	71	57	Safety Latch Kit	JLP300A-63-1PH
287803	JLP-300A-20SH	3	6,600	20	18-8/9	10 x 30	16-1/7	71	63		

JLP-A SERIES MINI-PULLER



SAFETY

- Weston style double ratchet pawl brake design splits the load to opposite sides of the ratchet gear for greater load security
- Industrial rated alloy steel hooks rotate 360 degrees for easy rigging and slowly stretch to indicate an overload situation

DURABILITY

- Grade 80 black oxide coated load chain for added durability
- Intended for the harshest environments, the heat treated load plates and case hardened corrosive resistant internal parts extend the life of the hoist
- Impact resistant all steel construction for added durability and protection
- The lightweight design with shorter handle and smaller body are ideal for confined areas and low headroom applications

STANDARDS

- This product complies with ANSI / ASME B30.21 and HST-3 Standards
- Load tested to 125% of capacity with certificate



BRAKE DESIGN

Weston style double ratchet pawl brake design splits the load to opposite sides of the ratchet gear for greater load security.

STOCK NO.	MODEL NO.	CAPACITY (TONS)	CAPACITY (LBS.)	STANDARD LIFT (FT.)	HEADROOM (IN.)	LOAD CHAIN (DIA/MM)	LEVER LENGTH (IN.)	POUNDS OF PULL TO LIFT CAPACITY	WEIGHT (LBS.)	REPLACEMENT PARTS	REPLACEMENT PART STOCK NO.
1/4-TON JLP-A SERIES LEVER HOISTS											
287100	JLP-025A-5	1/4	500	5	8-1/4	4 x 12	6	60	4-5/9	Top Hook	JLP25A-26G
287101	JLP-025A-10	1/4	500	10	8-1/4	4 x 12	6	60	5-5/6	Bottom Hook	JLP25A-38G
287102	JLP-025A-15	1/4	500	15	8-1/4	4 x 12	6	60	7	Safety Latch Kit	JLP25A-27-1
1/2-TON JLP-A SERIES LEVER HOISTS											
287200	JLP-050A-5	1/2	1,000	5	10	4.3 x 12	8-1/2	86	5-1/6	Top Hook	JLP25A-26G
287201	JLP-050A-10	1/2	1,000	10	10	4.3 x 12	8-1/2	86	6-5/6	Bottom Hook	JLP25A-38G
287202	JLP-050A-15	1/2	1,000	15	10	4.3 x 12	8-1/2	86	8-1/3	Safety Latch Kit	JLP25A-27-1

TECHNICAL SPECIFICATIONS AND COMPARISON WORKSHEET

COMPETITIVE COMPARISON

How Do We Stack Up- use the chart provided to see how the JET JLP-A Series Lever Hoist stacks up against the competition.

Model No.	JLP-A			
Headroom (In.)				
Brake Wear Indicator	✓			
Easy 2-Step Free Chaining	✓			
Weston Style Double Pawls	✓			
Ergonomic Grip	✓			
Cast Steel Safety Latches	✓			
Lifetime Warranty	✓			

JLP-A CHAIN LIMITS INFORMATION

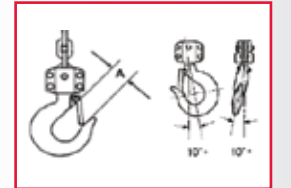
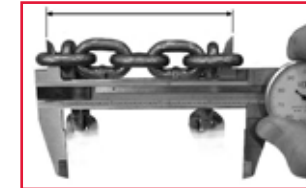
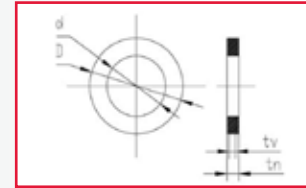

HOIST CAPACITY	OUTER DIAMETER (IN.)	INNER DIAMETER (IN.)	BRAKE PAD THICKNESS (IN.)	REPLACE DISCS IF ≤ (IN.)
1/4 Ton	1.38	0.87	0.14	0.12
1/2 Ton	1.89	1.00	0.12	0.10
3/4 Ton	2.13	1.34	0.14	0.12
1-1/2 Ton	2.56	1.59	0.14	0.12
3 Ton	2.56	1.59	0.14	0.12
6 Ton	2.56	1.59	0.14	0.12

HOIST CAPACITY	5 LINKS NORMAL (IN.)	5 LINKS LIMIT REPLACE IF ≥
1/4 Ton	2.36	2.433
1/2 Ton	2.36	2.433
3/4 Ton	3.54	3.629
1-1/2 Ton	4.72	4.838
3 Ton	5.91	6.058
6 Ton	5.91	6.058

HOIST CAPACITY	"A" DIMENSION NORMAL (IN.)	"A" DIMENSION REPLACE IF ≥
1/4 Ton	1.40	1.47
1/2 Ton	1.38	1.45
3/4 Ton	1.46	1.54
1-1/2 Ton	1.86	1.95
3 Ton	2.46	2.59
6 Ton	3.07	3.23

JLP-A TECHNICAL INFORMATION

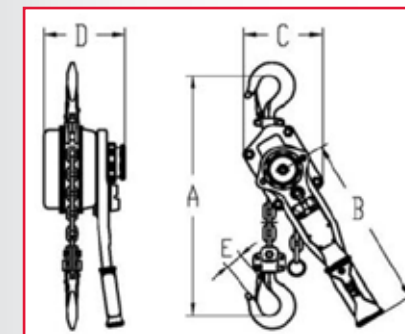

HOIST CAPACITY	"A"	"B"	"C"	"D"	"E"
JLP-25A	8.27	5.91	2.44	3.10	1.40
JLP-50A	10.4	8.46	2.68	3.74	1.38
JLP-75A	12.79	11.02	5.31	5.83	1.46
JLP-150A	14.96	16.14	6.37	6.77	1.85
JLP-300A	18.89	16.14	8.21	7.88	2.46
JLP-600A	24.41	16.14	9.76	7.88	3.07

PT SERIES HEAVY-DUTY MANUAL TROLLEYS



DURABILITY

- Welded all-steel frame and powder coat finish provide maximum durability and protection
- Hardened steel wheels and double sealed lubricated ball bearings provide smooth movement
- Built-in bumper guards increase user safety and extend the life of the trolley
- Easily adjustable to wide-flange H-beams, standard I-beams or curved track with the included spacer washers

STANDARDS

- This product complies with ANSI / ASME B30.11 and B30.17 Standards
- Load tested to 125% of capacity with certificate



STOCK NO.	252005	252010	252015	252020	252030	252050	252060
Model No.	1/2-PT	1-PT	1-1/2-PT	2-PT	3-PT	5-PT	10-PT
Capacity (Ton)	1/2	1	1-1/2	2	3	5	10
Capacity (Lbs.)	1,100	2,200	3,300	4,400	6,600	11,000	22,000
Beam Flange Capacity (Min. / Max) (In.)	2-1/2 - 8	3 - 8	3-1/4 - 8	3-1/4 - 8	4 - 8	4-5/8 - 8	4-3/4 - 8
Min. Curve Radius (In.)	39	39	43	43	51	55	67
Beam Height (Min./Max.) (In.)	4 - 19	4 - 19	4 - 19	4 - 19	5 - 19	5 - 19	6 - 19
Wheel Diameter (In.)	2-2/7	3	3-1/3	3-1/2	4-1/3	4-4/5	6
Wheel to Hook Mount (In.)	4-4/9	5	5-5/7	6	7-1/3	8-5/8	10-5/6
Max. Hook Size (W) (In.)	15/16	1-1/5	1-1/3	1-3/7	1-7/9	2-1/3	3-2/9
Overall Dimensions (L x W x H) (In.)	8-1/3 x 12-2/7 x 5-1/8	10 x 13 x 6	11 x 13-2/9 x 6-3/8	11-8/9 x 13-7/9 x 6-2/3	13-5/8 x 14-4/7 x 8-1/2	15 x 15-3/4 x 10	18 x 17 x 11-3/5
Weight (Lbs.)	19	33	41	51	83	120	202

HDT SERIES COMPACT MANUAL TROLLEYS



DURABILITY

- Welded all-steel frame and powder coat finish provide maximum durability and protection
- Hardened steel wheels and double sealed lubricated ball bearings provide smooth movement
- Built-in bumper guards increase user safety and extend the life of the trolley
- Easily adjustable to wide-flange H-beams, standard I-beams or curved track with the included spacer washers

STANDARDS

- This product complies with ANSI / ASME B30.11 and B30.17 Standards
- Load tested to 125% of capacity with certificate



STOCK NO.	262005	262010	262020	262030	262050
Model No.	1/2-HDT	1-HDT	2-HDT	3-HDT	5-HDT
Capacity (Ton)	1/2	1	2	3	5
Capacity (Lbs.)	1,100	2,200	4,400	6,600	11,000
Beam Flange Capacity (Min. / Max) (In.)	2-1/2 - 8	3 - 8	3-1/4 - 8	4 - 8	4-5/8 - 8
Min. Curve Radius (In.)	35	39	43	51	55
Beam Height (Min./Max.) (In.)	3 - 24-1/2	5 - 24-1/2	6 - 24-1/2	8 - 24-1/2	10 - 24-1/2
Wheel Diameter (In.)	2-13/16	2-1/2	3	3-15/16	4-3/4
Wheel to Hook Mount (In.)	4	4-11/16	5-3/8	6-7/16	7-11/16
Max. Hook Size (W x H) (In.)	15/16 x 1-1/4	1-3/16 x 1-11/16	1-1/2 x 2	1-3/4 x 2-9/16	2-1/8 x 3-3/8
Overall Dimensions (L x W x H) (In.)	7-3/8 x 11-13/16 x 4-5/8	8-3/8 x 12-1/2 x 5-1/8	10-3/16 x 13 x 6-5/16	12-3/8 x 13-3/4 x 7-7/16	14-13/16 x 14-13/16 x 8-9/16
Weight (Lbs.)	11	17	31	51	87

JBC SERIES HEAVY-DUTY BEAM CLAMPS



FEATURES

- Welded, enclosed pockets provide greater stability and durability where the beam clamp attaches to the beam/structure
- Larger, thicker diameter pins for increased durability and life

DURABILITY

- Welded all-steel frame and powder coat finish provide maximum durability and protection
- Clamp jaw is designed to distribute the load away from the beam flange edge increasing safety
- Used for quick mounting of a hoist or for lifting a broad range of beams

STANDARDS

- This product complies with ANSI / ASME B30.11 and B30.17 Standards
- Load tested to 125% of capacity with certificate



CLAMP SAFETY

Clamp jaw is designed to distribute the load away from the beam flange edge, increasing safety

STOCK NO.	252710	252720	252730	252750
Model No.	JBC-1	JBC-2	JBC-3	JBC-5
Capacity (Ton)	1	2	3	5
Capacity (Lbs.)	2,200	4,400	6,600	11,000
Beam Flange Capacity (Min. / Max) (In.)	2-31/32 - 8-5/8	2-31/32 - 8-5/8	3-15/16 - 9-5/8	4-15/16 - 10-5/8
Weight (Lbs.)	12	14	27	34

HD SERIES LARGE CAPACITY BEAM CLAMPS



FEATURES

- Welded, enclosed pockets provide greater stability and durability where the beam clamp attaches to the beam/structure
- Larger, thicker diameter pins for increased durability and life

DURABILITY

- Welded all-steel frame and powder coat finish provide maximum durability and protection
- Clamp jaw is designed to distribute the load away from the beam flange edge increasing safety
- Used for quick mounting of a hoist or for lifting a broad range of beams

STANDARDS

- This product complies with ANSI / ASME B30.11 and B30.17 Standards
- Load tested to 125% of capacity with certificate



CLAMP SAFETY

Clamp jaw is designed to distribute the load away from the beam flange edge, increasing safety

STOCK NO.	202710	202720	202730	202750
Model No.	HD-1T	HD-2T	HD-3T	HD-5T
Capacity (Ton)	1	2	3	5
Capacity (Lbs.)	2,200	4,400	6,600	11,000
Beam Flange Capacity (Min. / Max) (In.)	2-15/16 - 8-11/16	2-15/16 - 8-11/16	3-1/8 - 12-5/8	3-9/16 - 12-5/8
Weight (Lbs.)	10	11	21	24

JWS SERIES SAFETY COMES STANDARD



JWS SERIES WEB STRAP HOISTS

JET® lifting systems are comprised of the safest and most durable hoists for lifting, pulling and holding applications. All JET® hoists are engineered to meet strict tolerances and are constructed with quality materials to ensure they last. If you're looking for safety, dependability and durability, choose JET Lifting Systems.

CORROSION-RESISTANT

Corrosion-resistant stainless steel springs, bronze bushings, drum shafts, self lubricating bearings, and drop-forged steel hooks for added durability.

OPEN HOUSING DESIGN

Open housing design for quick cleaning and fast daily inspections.

ISOLATED RATCHETING GEAR

Isolated ratcheting gear, oversized strap guide, and bottom block assembly guides the web strap smoothly onto the drum and prevents the strap from binding.

FIBERGLASS HANDLE

Fiberglass handle material tested and certified to withstand 15kV/1 ft for 1 minute.

1:1 GEAR RATIO

1:1 gear ratio allows for low handle effort and up to 1-1/2" lift per 45° handle stroke.

360° SWIVEL HOOKS

Larger, easy opening, 360 degree swivel hooks with safety latches.

FRICTION BRAKE

Friction brake design and double interlocking pawls allow for micro-inching when lowering loads.



NEW

JWS SERIES WEB STRAP HOISTS



FEATURES

- Isolated ratcheting gear, oversized strap guide, and bottom block assembly guides the web strap smoothly onto the drum and prevents the strap from binding
- Corrosion-resistant stainless steel springs, bronze bushings, drum shafts, self lubricating bearings, and drop-forged steel hooks for added durability
- Friction brake design and double interlocking pawls allow for micro-inching when lowering loads
- 1:1 gear ratio allows for low handle effort and up to 1-1/2" lift per 45° handle stroke
- The ratcheting drum releases the web strap slack without freefalling
- Larger, easy opening, 360 degree swivel hooks with safety latches
- Open housing design for quick cleaning and fast daily inspections
- Fiberglass handle material tested and certified to withstand 15kV/1 ft for 1 minute
- This product complies with ANSI / ASME B30.21 Standards

STOCK NO.	352100	352110
Model No.	JWS-2A	JWS-3A
Single Pull Capacity (Ton)	1	1-1/2
Single Pull Distance (In. / Min.)	20	20
Single Pull Distance (In. / Max.)	72	72
Min. Distance Between Hooks (In.)	13-1/2	13-1/2
Strap Length (Ft.)	10	10
Handle Length (In.)	13	15
Net Weight	7-1/2	9

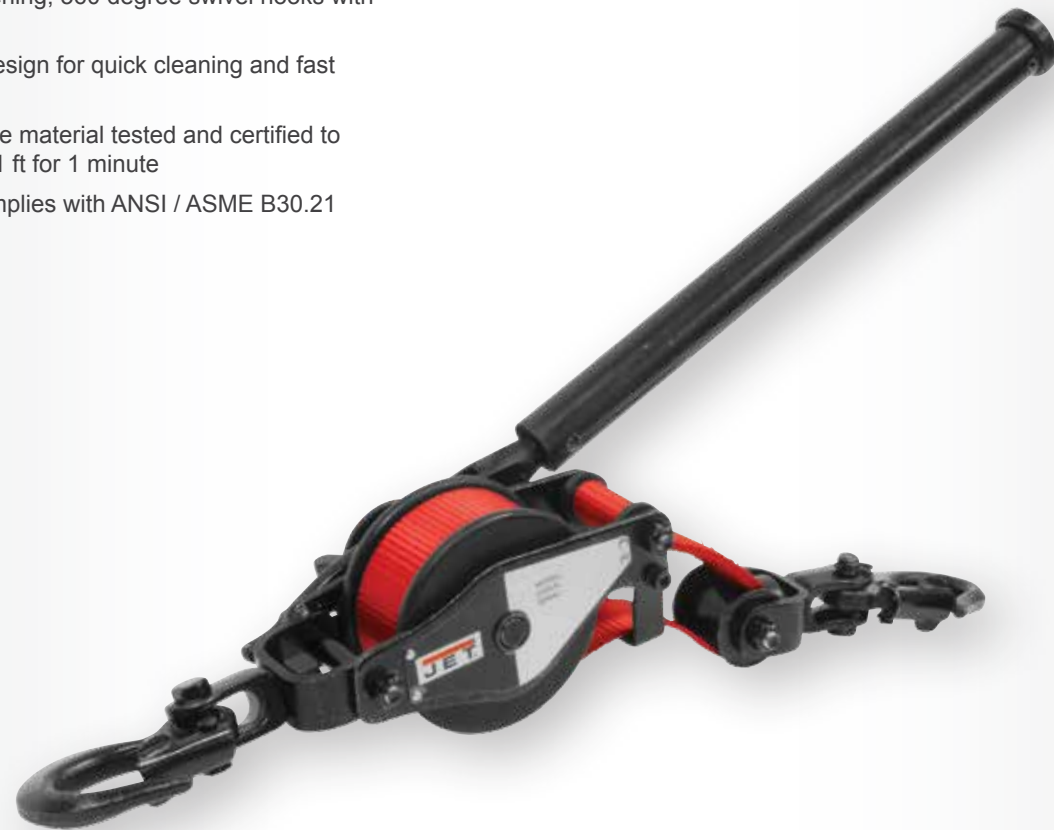

FEATURES

- Convertible web strap hoist quickly changes from a single line to a double line
- Isolated ratcheting gear, oversized strap guide, and bottom block assembly guides the web strap smoothly onto the drum and prevents the strap from binding
- Corrosion-resistant stainless steel springs, bronze bushings, drum shafts, self lubricating bearings, and drop-forged steel hooks for added durability
- Friction brake design and double interlocking pawls allow for micro-inching when lowering loads
- 1:1 gear ratio allows for low handle effort and up to 1-1/2" lift per 45° handle stroke
- Ratcheting drum releases the web strap slack without freefalling
- Larger, easy opening, 360 degree swivel hooks with safety latches
- Open housing design for quick cleaning and fast daily inspections
- Fiberglass handle material tested and certified to withstand 15kV/1 ft for 1 minute
- This product complies with ANSI / ASME B30.21 Standards

STOCK NO.	352105	352115
Model No.	JWS-25A	JWS-4A
Single Pull Capacity (Ton)	1/2	3/4
Single Pull Distance (In. / Min.)	20	20
Single Pull Distance (In. / Max.)	138	138
Double Pull Capacity (Ton)	1	1-1/2
Double Pull Distance (In. / Min.)	26	26
Double Pull Distance (In. / Max.)	76	76
Min. Distance Between Hooks (In.)	20	20
Strap Length (Ft.)	10	10
Handle Length (In.)	13	15
Net Weight	10	12



JCP SERIES CABLE PULLERS



FEATURES

- General purpose cable puller designed to lift, lower, stretch or pull heavy loads
- 1 ton to 4 ton capacities
- Lightweight zinc plated steel construction to resist corrosion
- Double solid cast aluminum ratchet wheel brake system hold load securely in any position
- Concealed spring lever control prevents accidental release
- Drop forged hooks with safety latches standard
- Aircraft quality 3/16" cable
- Snatch block included with JCP-2 and JCP-4 models
- This product complies with ANSI / ASME B30.21 Standards
- Load tested to 125% of capacity with certificate

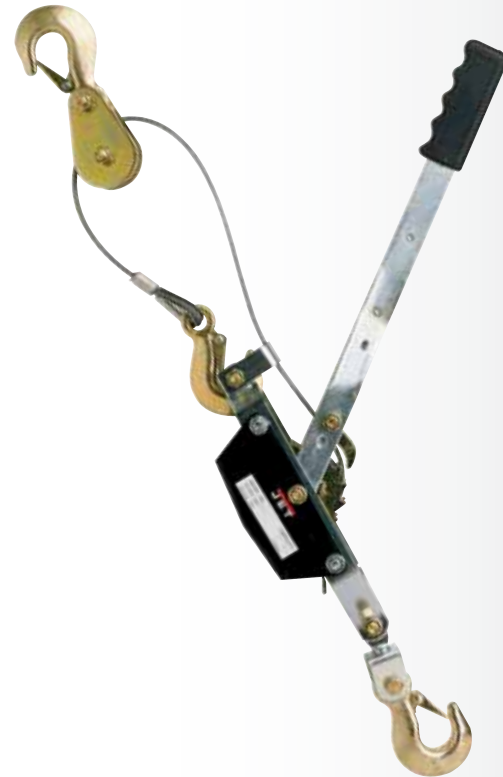

STOCK NO.	180410	180420	180440
Model No.	JCP-1	JCP-2	JCP-4
Capacity (Ton)	1	2	4
Lever Ratio	18:1	36:1	36:1
Maximum Lift (Ft.)	12	5	5
Lever Length (In.)	16-1/2	16-1/2	17-1/8
Minimum Distance Between Hooks (In.)	17	21	22
Wire Rope Diameter (In.)	3/16	3/16	1/4
Weight (Lbs.)	7	9	13

JG SERIES GRIP PULLERS



FEATURES

- Industrial quality grip puller designed to lift, lower or pull heavy loads
- 3/4 ton to 3 ton pulling capacities
- Easy to use in any direction, angle, length of pull or lift
- Multiple clutch brake system holds load in any position
- Safety shear pin in telescopic handle provides automatic overload protection
- Heavy-duty safety hooks with spring loaded latches
- Available with or without 66 ft of wire rope

JG SERIES GRIP PULLER SPECIFICATIONS

STOCK NO.	286575K	286515K	286530K
Model No.	JG-75A	JG-150A	JG-300A
Pulling Capacity (Lbs.)	2,750	5,500	11,000
Lifting Capacity (Lbs.)	1,650	3,300	6,600
Handle Length (In.)	29-1/2	41	46-1/2
Distance Per Stroke (In.)	2-9/32	2-3/8	1-1/2
Wire Rope Diameter (In.)	5/16	7/16	5/8
Lifting Speed (FPM)	10	10	10
Overall Dimensions (L x W x H) (In.)	16-3/4 x 2-1/2 x 9-1/4	21-1/2 x 3-7/8 x 11	26 x 4-1/2 x 12-3/4
Weight (Lbs.)	36	48	123



WIRE ROPE SPECIFICATIONS

STOCK NO.	MODEL	DIAMETER (IN)	WEIGHT (LBS)
286574	WR-75A	5/16	15
286514	WR-150A	7/16	28
286529	WR-300A	5/8	41



VOLT SERIES DURABILITY & INNOVATION



H4 DUTY RATING

The H4 Duty Rating means the VOLT is engineered for demanding duty cycles and the toughest applications.

ELECTROMAGNETIC BRAKE

The heavy-duty DC electromagnetic brake design is an industry-proven safety feature that secures the load even if power is interrupted to the hoist.

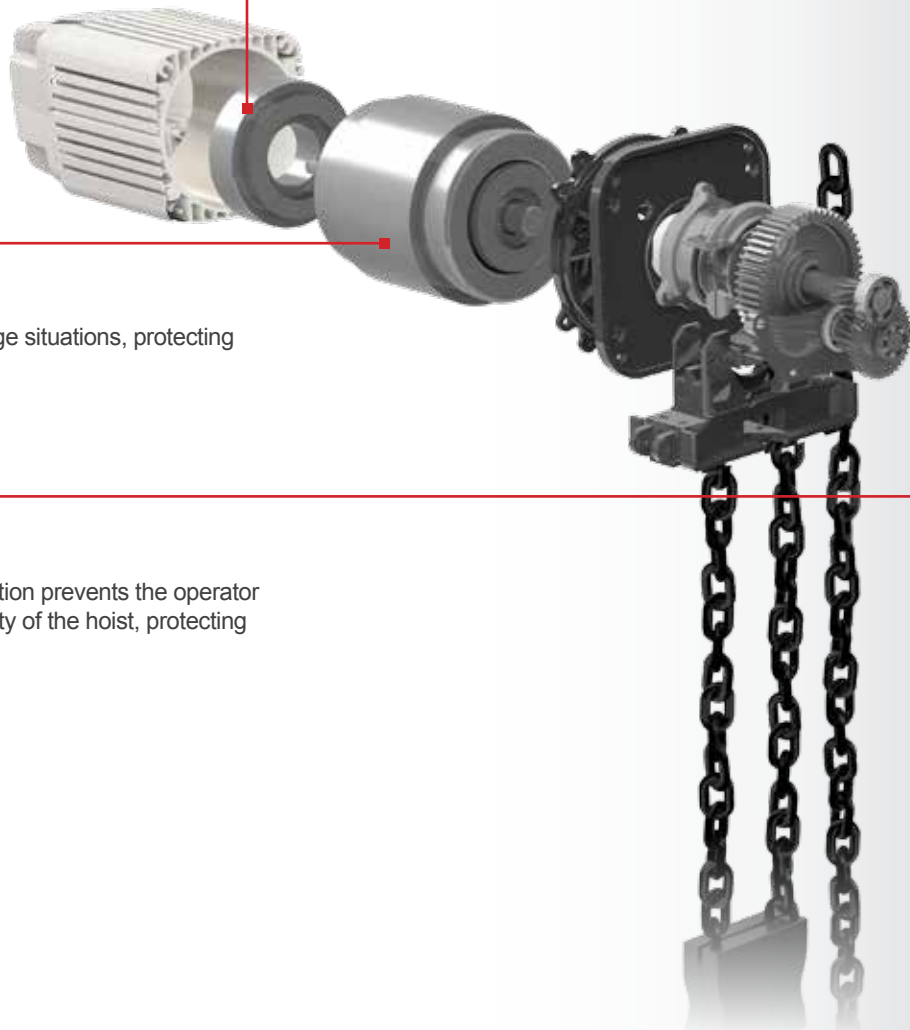

THERMAL OVERLOAD PROTECTION

Protects the motor from overheating in low voltage situations, protecting your investment.

OVERLOAD PROTECTION

Standard across the VOLT line, Overload Protection prevents the operator from being able to lift more than the rated capacity of the hoist, protecting both the user and the equipment.



FULL-RANGE SPEED CONTROL

Patent-pending, the Full-Range Speed Control technology means seamless speed changes and total control at your fingertips.



HITACHI INVERTER

When precision matters, you want a hoist that gives you the maneuverability to accurately control the placement of a load. Proprietary software technology controlled by the Hitachi inverter ensures smooth, continuous control with soft starts and stops throughout the lift.

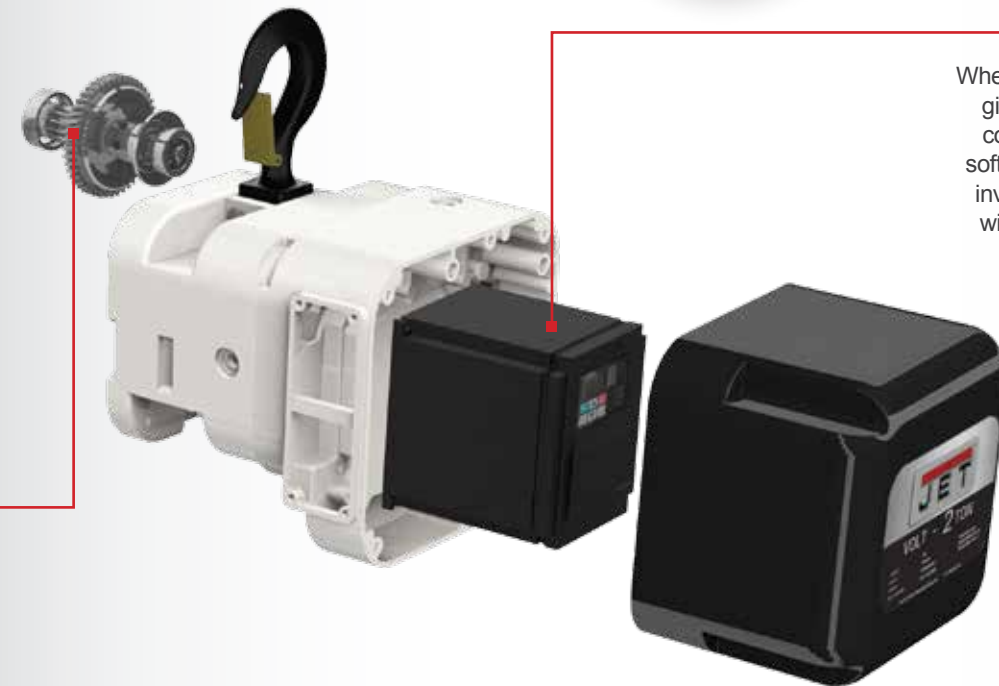

VOLT

VARIABLE-SPEED OVERHEAD
LIFTING TECHNOLOGY

AN IN-DEPTH LOOK AT THE VOLT SAFETY AND DURABILITY



CONTROL

- Patented electronic variable speed technology allows for the lifting speed to be adjusted to the application
- Eliminates bump-firing when positioning the work piece reducing downtime and hoist maintenance

PRECISION

- Minimum speed allows the work piece to be slowly inched down for a soft stop
- Soft start and stops increase the life of the geartrain components, load chain hooks, and brake components

SAFETY & DURABILITY

- H4 Duty Rating means the VOLT is engineered for demanding, industrial environments and the toughest applications
- Overload Protection prevents the operator from being able to lift more than the rated capacity of the hoist
- Electromagnetic brake design is an industry-proven safety feature that secures the load even if power is interrupted to the hoist
- Thermal overload protection protects the motor from overheating in low voltage situations
- Grade 80 black oxide coated load chain for industry proven durability
- Heavy-duty nylon chain bag with reinforcing metal brackets included
- 24 volt 2-button push-button controller is included

STANDARDS

- This product complies with ANSI / ASME B30.16 and HST-1 Standards
- Load tested to 125% of capacity with certificate
- Patent Pending



VOLT SERIES VARIABLE SPEED ELECTRIC HOISTS SPECIFICATIONS



STOCK NO.	MODEL NO.	CAPACITY (TONS)	STANDARD LIFT (FT.)	MOTOR	PHOASE	VOLTAGE	HEADROOM (IN.)	DUTY CYCLE RATING	DUTY CYCLE	MAX ON TIME MIN./HR.	MAX. NO. STARTS	LIFTING SPEED (FPM)
1/4-TON 1 PHASE/3 PHASE												
182510	VOLT-025-13P-10	1/4	10	1-1/2	1/3	230v	19-7/8	H4	50%	30	300	0-55
182515	VOLT-025-13P-15	1/4	15	1-1/2	1/3	230v	19-7/8	H4	50%	30	300	0-55
182520	VOLT-025-13P-20	1/4	20	1-1/2	1/3	230v	19-7/8	H4	50%	30	300	0-55
1/2-TON 1 PHASE/3 PHASE												
185010	VOLT-050-13P-10	1/2	10	1-1/2	1/3	230v	19-7/8	H4	50%	30	300	0-39
185015	VOLT-050-13P-15	1/2	15	1-1/2	1/3	230v	19-7/8	H4	50%	30	300	0-39
185020	VOLT-050-13P-20	1/2	20	1-1/2	1/3	230v	19-7/8	H4	50%	30	300	0-39
1-TON 1 PHASE/3 PHASE												
181110	VOLT-100-13P-10	1	10	3	1/3	230v	21-5/8	H4	40%	24	240	0-39
180115	VOLT-100-13P-15	1	15	3	1/3	230v	21-5/8	H4	40%	24	240	0-39
180120	VOLT-100-13P-20	1	20	3	1/3	230v	21-5/8	H4	40%	24	240	0-39
2-TON 1 PHASE/3 PHASE												
180210	VOLT-200-13P-10	2	10	4	1/3	230v	23-3/4	H4	50%	30	300	0-24
180215	VOLT-200-13P-15	2	15	4	1/3	230v	23-3/4	H4	50%	30	300	0-24
180220	VOLT-200-13P-20	2	20	4	1/3	230v	23-3/4	H4	50%	30	300	0-24
3-TON 1 PHASE/3 PHASE												
180310	VOLT-300-13P-10	3	10	4	1/3	230v	23-3/4	H4	40%	24	240	0-24
180315	VOLT-300-13P-15	3	15	4	1/3	230v	23-3/4	H4	40%	24	240	0-24
180230	VOLT-300-13P-20	3	20	4	1/3	230v	23-3/4	H4	40%	24	240	0-24
5-TON 1 PHASE/3 PHASE												
180501	VOLT-500-13P-10	5	10	4	1/3	230v	26-3/16	H4	40%	24	240	0-12
180515	VOLT-500-13P-15	5	15	4	1/3	230v	26-3/16	H4	40%	24	240	0-12
181520	VOLT-500-13P-20	5	20	4	1/3	230v	26-3/16	H4	40%	24	240	0-12
10-TON 1 PHASE/3 PHASE												
181010	VOLT-1000-13P-10	10	10	4	1/3	230v	56-3/8	H4	40%	24	240	0-12
181015	VOLT-1000-13P-15	10	15	4	1/3	230v	56-3/8	H4	40%	24	240	0-12
181020	VOLT-1000-13P-20	10	20	4	1/3	230v	56-3/8	H4	40%	24	240	0-12

STOCK NO.	MODEL NO.	CAPACITY (TONS)	STANDARD LIFT (FT.)	MOTOR	PHOASE	VOLTAGE	HEADROOM (IN.)	DUTY CYCLE RATING	DUTY CYCLE	MAX ON TIME MIN./HR.	MAX. NO. STARTS	LIFTING SPEED (FPM)
1/4-TON 3 PHASE												
182511	VOLT-025-03P-10	1/4	10	1-1/2	3	460v	19-7/8	H4	50%	30	300	0-55
182516	VOLT-025-03P-15	1/4	15	1-1/2	3	460v	19-7/8	H4	50%	30	300	0-55
182521	VOLT-025-03P-20	1/4	20	1-1/2	3	460v	19-7/8	H4	50%	30	300	0-55
1/2-TON 3 PHASE												
185011	VOLT-050-03P-10	1/2	10	1-1/2	3	460v	19-7/8	H4	50%	30	300	0-39
185016	VOLT-050-03P-15	1/2	15	1-1/2	3	460v	19-7/8	H4	50%	30	300	0-39
185021	VOLT-050-03P-20	1/2	20	1-1/2	3	460v	19-7/8	H4	50%	30	300	0-39
1-TON 3 PHASE												
180111	VOLT-100-03P-10	1	10	3	3	460v	21-5/8	H4	40%	24	240	0-39
180116	VOLT-100-03P-15	1	15	3	3	460v	21-5/8	H4	40%	24	240	0-39
180121	VOLT-100-03P-20	1	20	3	3	460v	21-5/8	H4	40%	24	240	0-39
2-TON 3 PHASE												
180211	VOLT-200-03P-10	2	10	4	3	460v	23-3/4	H4	50%	30	300	0-24
180216	VOLT-200-03P-15	2	15	4	3	460v	23-3/4	H4	50%	30	300	0-24
180221	VOLT-200-03P-20	2	20	4	3	460v	23-3/4	H4	50%	30	300	0-24
3-TON 3 PHASE												
180311	VOLT-300-03P-10	3	10	4	3	460v	23-3/4	H4	40%	24	240	0-24
180316	VOLT-300-03P-15	3	15	4	3	460v	23-3/4	H4	40%	24	240	0-24
180321	VOLT-300-03P-20	3	20	4	3	460v	23-3/4	H4	40%	24	240	0-24
5-TON 3 PHASE												
180511	VOLT-500-03P-10	5	10	4	3	460v	26-3/16	H4	40%	24	240	0-12
180516	VOLT-500-03P-15	5	15	4	3	460v	26-3/16	H4	40%	24	240	0-12
180521	VOLT-500-03P-20	5	20	4	3	460v	26-3/16	H4	40%	24	240	0-12
10-TON 3 PHASE												
181011	VOLT-1000-03P-10	10	10	4	3	460v	56-3/8	H4	40%	24	240	0-12
181016	VOLT-1000-03P-15	10	15	4	3	460v	56-3/8	H4	40%	24	240	0-12
181021	VOLT-1000-03P-20	10	20	4	3	460v	56-3/8	H4	40%	24	240	0-12

4-BUTTON PENDANT CONTROLS

FEATURES

- 24 volt push button controller with cable strain relief system for durability and reliability
- 4 button controller for electric hoist or trolley feature
- 4-pin quick connect plugs



STOCK NUMBER	MODEL NO.	DESCRIPTION
162410	PBC-410VOLT	VOLT 4 BTN PNDDT 10' Lift
162415	PBC-415VOLT	VOLT 4 BTN PNDDT 15' Lift
162420	PBC-420VOLT	VOLT 4 BTN PNDDT 20' Lift
162430	PBC-430VOLT	VOLT 4 BTN PNDDT 30' Lift

JSH & SSC SERIES ELECTRIC HOISTS



SAFETY

- All SSC Series electric hoists have a slip clutch style overload protection that prevents the hoist from lifting damaging loads above its rated capacity
- Thermal Overload Protection- Protects the hoist from overheating in low voltage situations
- DC Electromagnetic brake design is an industry-proven safety feature that secures the load even if power is interrupted to the hoist.
- Upper and lower limiting switches increase safety by preventing the load chain from over traveling

DURABILITY

- Gear train incorporates a sealed oil bath that eliminates up-keep
- Grade 80 black oxide coated load chain for added durability
- Fully enclosed, all steel plate construction and powder coat finish keeps out dust and debris lengthening the life of the hoist
- 24 volt 2-button pendant controller with cable strain relief system is included

STANDARDS

- This product complies with ANSI / ASME B30.16 and HST-1 Standards
- Load tested to 125% of capacity with certificate
- Push button control pendants are NEMA 4x compliant



JSH SERIES SPECIFICATIONS

STOCK NO.	MODEL NO.	STANDARD LIFT (FT.)	DUTY CYCLE RATING	DUTY CYCLE	LIFTING SPEED (FPM)	HEADROOM (IN.)	PUSH BUTTON CONTROL CORD LENGTH (FT.)	MOTOR OUTPUT (HP.)	RATED AMPS	LOAD CHAIN DIAMETER (MM.)	NUMBER OF FALLS	NET WEIGHT (LBS.)
1/8-TON SINGLE SPEED 1 PHASE*									115V			
110100	JSH-275-10	10	H3	25%	16	15-1/4	8	1/6	3	4	1	34
110115	JSH-275-15	15	H3	25%	16	15-1/4	13	1/6	3	4	1	35
110120	JSH-275-20	20	H3	25%	16	15-1/4	18	1/6	3	4	1	37
1/4-TON SINGLE SPEED 1 PHASE*												
110110	JSH-550-10	10	H3	25%	8	17-1/10	8	1/6	3	4	2	38
110515	JSH-550-15	15	H3	25%	8	17-1/10	13	1/6	3	4	2	40
110520	JSH-550-20	20	H3	25%	8	17-1/10	18	1/6	3	4	2	43

*CUSTOM LIFTS AVAILABLE IN ALL CAPACITIES IN 5 FT INCREMENTS

SSC SERIES SPECIFICATIONS

STOCK NO.	MODEL NO.	STANDARD LIFT (FT.)	DUTY CYCLE RATING	DUTY CYCLE	LIFTING SPEED (FPM)	HEADROOM (IN.)	PUSH BUTTON CONTROL CORD LENGTH (FT.)	MOTOR OUTPUT (HP.)	RATED AMPS	LOAD CHAIN DIAMETER (MM.)	NUMBER OF FALLS	NET WEIGHT (LBS.)
1/2-TON SINGLE SPEED 1 PHASE*									115V 230V			
121100	1/2SS-1C-10	10	H3	25%	19.7	20-3/16	8	7/8	12.6	6	6.3	101-1/2
121150	1/2SS-1C-15	15	H3	25%	19.7	20-3/16	13	7/8	12.6	6	6.3	106
121200	1/2SS-1C-20	20	H3	25%	19.7	20-3/16	18	7/8	12.6	6	6.3	108
1-TON SINGLE SPEED 1 PHASE*												
111000	1SS-1C-10	10	H3	25%	19.7	24-7/16	8	1-3/4	20.8	10	8	161
111500	1SS-1C-15	15	H3	25%	19.7	24-7/16	13	1-3/4	20.8	10	8	165-1/2
112000	1SS-1C-20	20	H3	25%	19.7	24-7/16	18	1-3/4	20.8	10	8	172
2-TON SINGLE SPEED 1 PHASE*												
211000	2SS-1C-10	10	H3	25%	9.8	28-1/8	8	1-3/4	20.8	10	8	167-1/2
211500	2SS-1C-15	15	H3	25%	9.8	28-1/8	13	1-3/4	20.8	10	8	178-1/2
212000	2SS-1C-20	20	H3	25%	9.8	28-1/8	18	1-3/4	20.8	10	8	187-1/2
3-TON SINGLE SPEED 1 PHASE*												
311000	3SS-1C-10	10	H3	25%	6.6	31-1/2	8	1-3/4	20.8	10	8	198-1/2
311500	3SS-1C-15	15	H3	25%	6.6	31-1/2	13	1-3/4	20.8	10	8	214
312000	3SS-1C-20	20	H3	25%	6.6	31-1/2	18	1-3/4	20.8	10	8	227
5-TON SINGLE SPEED 1 PHASE*												
511000	5SS-1C-10	10	H3	25%	4.9	30-11/16	8	1-3/4	22	10.5	8	218
511500	5SS-1C-15	15	H3	25%	4.9	30-11/16	13	1-3/4	22	10.5	8	238
512000	5SS-1C-20	20	H3	25%	5	30-11/16	18	1-3/4	22	10.5	8	220
1/2-TON SINGLE SPEED 3 PHASE*									230V 460V			
123100	1/2SS-3C-10	10	H4	30%	31.5	20-3/16	8	1-1/5	3.5	1.8	8	92-1/2
123150	1/2SS-3C-15	15	H4	30%	31.5	20-3/16	13	1-1/5	3.5	1.8	8	97
123200	1/2SS-3C-20	20	H4	30%	31.5	20-3/16	18	1-1/5	3.5	1.8	8	99
1-TON SINGLE SPEED 3 PHASE*												
131000	1SS-3C-10	10	H4	30%	24.8	24-7/16	8	2-1/7	5.9	3	8	150
131500	1SS-3C-15	15	H4	30%	24.8	24-7/16	13	2-1/7	5.9	3	8	154-1/2
132000	1SS-3C-20	20	H4	30%	24.8	24-7/16	18	2-1/7	5.9	3	8	161
2-TON SINGLE SPEED 3 PHASE*												
231000	2SS-3C-10	10	H4	30%	12.4	28-1/8	8	2-1/7	5.9	3	8	156-1/2
231500	2SS-3C-15	15	H4	30%	12.4	28-1/8	13	2-1/7	5.9	3	8	167-1/2
232000	2SS-3C-20	20	H4	30%	12.4	28-1/8	18	2-1/7	5.9	3	8	176-1/2
3-TON SINGLE SPEED 3 PHASE*												
331000	3SS-3C-10	10	H4	30%	8.3	31-1/2	8	2-1/7	5.9	3	8	187-1/2
331500	3SS-3C-15	15	H4	30%	8.3	31-1/2	13	2-1/7	5.9	3	8	203
332000	3SS-3C-20	20	H4	30%	8.3	31-1/2	18	2-1/7	5.9	3	8	216
5-TON SINGLE SPEED 3 PHASE*												
531000	5SS-3C-10	10	H4	30%	6.2	30-11/16	8	2-1/7	5.9	3	8	207
531500	5SS-3C-15	15	H4	30%	6.2	30-11/16	13	2-1/7	5.9	3	8	227
530200	5SS-3C-20	20	H4	30%	6.2	30-11/16	18	2-1/7	5.9	3	8	247

*CUSTOM LIFTS AVAILABLE IN ALL CAPACITIES IN 5 FT INCREMENTS

ET SERIES ELECTRONIC TROLLEYS



DURABILITY

- Easily adjustable to wide-flange H-beams, standard I-beams or, curved track with the included spacer washers
- Solenoid-operated traveling brake provides precise user control

STANDARDS

- This product complies with ANSI / ASME B30.11 and B30.17 Standards
- Load tested to 125% of capacity with certificate

ACCESSORIES

- Optional 4-button controllers available for a variety of configurations
- Lug Mount kits available for low headroom applications



STOCK NO.	272705	272710	272720	272730	272750
Model No.	1/2ET-1C	1ET-1C	2ET-1C	3ET-1C	5ET-1C
Capacity (Ton)	1/2	1	2	3	5
Capacity (Lbs.)	1,100	2,200	4,400	6,600	11,000
Travel Speed (FPM)	39-1/3	39-1/3	39-1/3	39-1/3	39-1/3
Beam Flange Capacity (Min. / Max) (In.)	3 - 5	3 - 5	4 - 6	4 - 6	5 - 7
Min Curve Radius (In.)	43-1/3	43-1/3	59	59	78-3/4
Wheel Diameter (In.)	3-1/2	3-1/2	4-1/2	5	6
Wheel to Hook Mount (In.)	6-1/2	6-1/2	7-43/64	9-5/32	10-1/2
Duty Cycle Rating	25%	25%	25%	25%	25%
Motor	1/2 HP, 115/230V, 1Ph	1/2 HP, 115/230V, 1Ph	1/2 HP, 115/230V, 1Ph	1 HP, 115/230V, 1Ph	1 HP, 115/230V, 1Ph
Overall Dimensions (L x W x H) (In.)	9-2/3 x 19-1/8 x 10	9-2/3 x 19-1/8 x 10	12-2/3 x 20-3/8 x 11-1/2	12-4/9 x 22-5/6 x 14-1/6	13-1/4 x 24-1/3 x 16-1/2
Weight (Lbs.)	93	93	122	161	218

STOCK NO.	262605	262610	262620	262630	262650
Model No.	1/2ET-3C	1ET-3C	2ET-3C	3ET-3C	5ET-3C
Capacity (Ton)	1/2	1	2	3	5
Capacity (Lbs.)	1,100	2,200	4,400	6,600	11,000
Travel Speed (FPM)	39-1/3	39-1/3	39-1/3	39-1/3	39-1/3
Beam Flange Capacity (Min. / Max) (In.)	3 - 5	3 - 5	4 - 6	4 - 6	5 - 7
Min Curve Radius (In.)	43-1/3	43-1/3	59	59	78-3/4
Wheel Diameter (In.)	3-1/2	3-1/2	4-1/2	5	6
Wheel to Hook Mount (In.)	6-1/2	6-1/2	7-43/64	9-5/32	10-1/2
Duty Cycle Rating	1/2 HP, 230/460V, 3Ph	1/2 HP, 230/460V, 3Ph	1/2 HP, 230/460V, 3Ph	1 HP, 230/460V, 3Ph	1 HP, 230/460V, 3Ph
Motor	9-2/3 x 19-1/8 x 10	9-2/3 x 19-1/8 x 10	12-2/3 x 20-3/8 x 11-1/2	12-4/9 x 22-5/6 x 14-1/6	13-1/4 x 24-1/3 x 16-1/2
Overall Dimensions (L x W x H) (In.)	88	88	117	156	213
Weight (Lbs.)	93	93	122	161	218

PENDANT CONTROLS & LUG MOUNT KITS



PENDANT CONTROLS FEATURES

- 24 volt push button controller with cable strain relief system for durability and reliability
- 4 button controller for electric hoist or trolley feature 4-pin quick connect plugs
- Water tight, dust tight and corrosion resistant for NEMA 4X rated control pendant
- Suitable for indoor and outdoor applications
- NEMA 4X enclosures provide a higher degree of protection against corrosive elements when exposed to extreme and harsh environments



PENDANT CONTROLS SPECIFICATIONS

STOCK NO.	152411	152416	152421	152431
Model No.	PBC-410CN	PBC-415CN	PBC-420CN	PBC-430CN
Control Type	4 Button	4 Button	4 Button	4 Button
Cord Length (Ft.)	10	15	20	30

LUG MOUNT KIT FEATURES

- Reduces headroom of electric hoist and trolley combinations up to 7 inches
- Increases stability of hoist and trolley combinations
- All steel construction for increased durability
- Easily installed on SSC Series Electric Hoists
- Uses existing hoist hanger included with electric trolley
- For use with SSC series hoists and ET series trolleys only



LUG MOUNT KIT SPECIFICATIONS

STOCK NO.	1/2SS-3C-LMA	1SS-3C-LMA	2SS-3C-LMA	3SS-3C-LMA	5SS-3C-LMA
Capacity (Ton)	1/2	1	2	3	5
Reduced Headroom (In.)	5	5	6	6	7

JHJ SERIES INDUSTRIAL BOTTLE JACKS



FEATURES

- Precision machined and polished cylinders provide non-abrasive, leak-free, durable performance
- Chrome-plated piston and ram are corrosion resistant for use in any industrial environment
- Hydraulic system is protected from damage by internal by-pass mechanism
- Heavy-duty base is electrically welded providing a stable platform
- Industrial-duty construction permits use in extreme climates
- Lifting, pushing, spreading, bending, pressing or straightening capabilities
- Upright, horizontal or angled operating positions increase versatility
- Rebuild/Repair Kits available
- Pump handle included
- Complies with ANSI/ASME B30.1 and PALD-1 Standards



NOTE

When used at an angle or in the horizontal position, the pump must be in upright position and piston movement is reduced. Load must still be level or perpendicular to the jack.



JHJ SERIES INDUSTRIAL BOTTLE JACKS

STOCK NO.	453301	453303	453305	453308	453312	453317	453322	453335K	453360K	453399K
Model No.	JHJ-2	JHJ-3	JHJ-5	JHJ-8	JHJ-12 1/2	JHJ-17 1/2	JHJ-22 1/2	JHJ-35	JHJ-60	JHJ-100
Rated Capacity (Tons)	2	3	5	8	12-1/2	17-1/2	22-1/2	35	60	100
Minimum Height (In.)	7-1/8	7-1/2	7-7/8	7-7/8	9-1/2	10-3/8	10-5/8	11	12	12
Piston Height (In.)	4-1/2	4-1/2	4-5/8	4-5/8	5-7/8	6-1/2	6-1/4	6-1/4	6-3/4	5-23/32
Head Screw (In.)	2	2-3/8	2-3/4	2-3/4	3-1/8	3-1/8	-	-	-	-
Maximum Height (In.)	13-5/8	14-3/8	15-1/2	15-1/2	18-1/2	20	16-7/8	17-1/4	8-5/8	7-11/16
Base Size (L x W) (In.)	4-1/2 x 2-1/2	4-9/16 x 2-13/16	5-5/8 x 3-1/4	6 x 3-1/2	6-1/2 x 4-1/8	7-1/8 x 4-5/8	7-1/8 x 5-1/2	8-3/8 x 5-1/2	9-1/4 x 7-3/8	15 x 10-7/16
Weight (Lbs.)	5	6	9	13	18	24	28	48	82	225
Rebuild / Repair Kit Stock #	JHJ001-RK	JHJ003-RK	JHJ005-RK	JHJ008-RK	JHJ012-RK	JHJ017-RK	JHJ022-RK	JHJ035-RK	JHJ060-RK	JHJ100-RK

LOW PROFILE JHJ SERIES INDUSTRIAL BOTTLE JACKS

STOCK NO.	453313K	453318K	453323K
Model No.	JHJ-12 1/2LP	JHJ-17 1/2LP	JHJ-22 1/2LP
Rated Capacity (Tons)	12-1/2	17-1/2	22-1/2
Minimum Height (In.)	6-3/4	6-3/4	7-1/8
Piston Height (In.)	3-3/4	3-1/2	3-3/8
Head Screw (In.)	3	2-3/4	1-1/2
Maximum Height (In.)	13-3/8	13	12
Base Size (L x W) (In.)	6-1/2 x 4-1/8	7-1/8 x 4-5/8	7-1/4 x 5-1/16
Weight (Lbs.)	15	19	23
Rebuild / Repair Kit Stock #	JHJ012-RK	JHJ017-RK	JHJ022-RK



JTJ SERIES INDUSTRIAL TOE JACKS



FEATURES

- Overload Protection valve prevents lifting loads past maximum capacity
- Electric welded bases and cylinders virtually eliminating leaks for proven reliability
- High or low extreme temperature fluctuations do not affect jack performance increasing durability
- Heat treated piston resists corrosion
- Spring assisted return and over-travel protection increases tool life
- Dual purpose jack designed for low or high clearances increases versatility
- Lifting, pushing, spreading, bending, pressing or straightening capabilities for multi-function use
- Pump handle included
- Complies with ANSI/ASME B30.1 Standards



STOCK NO.	454502	454505	454510
Model No.	JTJ-2ST	JTJ-5ST	JTJ-10ST
Rated Toe Capacity (Tons)	2	5	10
Rated Head Capacity (Tons)	3	6	14
Toe Minimum Height (In.)	5/8	1-1/16	1-7/32
Toe Maximum Height (In.)	5-1/16	5-3/4	6-15/16
Toe Lift (In.)	4-7/16	4-11/16	5-23/32
Head Minimum Height (In.)	9-1/4	11-1/2	12-7/8
Head Maximum Height (In.)	13-3/4	16-1/4	18-9/16
Toe Size (L x W) (In.)	2 x 2	2-1/2 x 3	2-5/7 x 3-2/7
Base Size (L x W) (In.)	4-15/16 x 7	10-5/8 x 7-3/16	11-9/32 x 9-7/16
Weight (Lbs.)	20	48	81

AHJ SERIES AIR/HYDRAULIC BOTTLE JACKS



FEATURES

- Labor saving air pump that connects to a pneumatic source for increased lifting speed
- Electric welded bases and cylinders virtually eliminating leaks for proven reliability
- High or low extreme temperature fluctuations do not affect jack performance increasing location versatility
- Includes a heavy-duty molded case that protects from normal wear and tear
- Lifting, pushing, spreading, bending, pressing or straightening capabilities for multi-function use
- Upright, horizontal or angled operating positions increases versatility
- Rebuild/Repair Kits available
- Complies with ANSI/ASME B30.1 and PALD-1 Standards



NOTE
When used at an angle or in the horizontal position, the pump must be in upright position and piston movement is reduced. Load must still be level or perpendicular to the jack.

STOCK NO.	456612	456620
Model No.	AHJ-12	AHJ-20
Load Capacity (Tons)	12	20
Piston Lift (In.)	4-1/2	4-1/2
Minimum Height (In.)	9-2/3	9-2/3
Maximum Height (In.)	18-2/3	18-2/3
Air Pressure Required (PSI)	90 - 145	90 - 145
Base Dimensions (L x W) (In.)	8-1/4 x 6-2/7	8-2/3 x 6-8/9
Weight (Lbs.)	25	40
Rebuild / Repair Kit A11:C11 #	AHJ12-RP	AHJ20-RP

SJ SERIES SCREW JACKS



FEATURES

- Industrial design eliminates creeping when holding heavy loads
- Heavy-duty cast bell shaped base provides a stable foundation in multiple lifting environments
- Corrugated pivoting head, contours to the load providing maximum surface contact
- Improved design requires less effort to lift a maximum capacity load
- Turning bar not included (available separately)
- Complies with ANSI/ASME B30.1 Standards

SJ SERIES SCREW JACK

STOCK NO.	441305	441310	441315	441320	441325
Model No.	SJ-5	SJ-10	SJ-15	SJ-20	SJ-25
Rated Capacity (Tons)	5	10	15	20	25
Height Closed (In.)	9	11	13-3/4	16	16-1/2
Height Extended (In.)	13	17-1/2	21	25	25-1/4
Head Diameter (In.)	2-3/8	3-1/16	3-1/2	4-1/8	4-3/8
Screw Size (od x L) (In.)	1 x 6	1-1/2 x 8-3/8	1-5/8 x 10-1/2	2 x 12	2-1/2 x 12
Bar Hole Size (In.)	9/16	11/16	13/16	13/16	13/16
Base Size (In.)	4-1/2	5-1/4	6	6-7/8	8
Weight (Lbs.)	7	19	28	36	44



SCREW JACK TURNING BARS

STOCK NO.	440301	440302	440303	440304
Model No.	SJTB-1/2	SJTB-5/8	SJTB-3/4	SJTB-1
Size (In.)	1/2 x 18	5/8 x 24	3/4 x 36	3/4 x 42
Fits Jack	SJ-5	SJ-10	SJ-15-25	SJ-15-25
Weight (Lbs.)	3	4	5	8

SLT SERIES SCISSOR LIFT TABLES



FEATURES

- Overload Protection ball valve prevents lifting loads past maximum capacity
- Top-Stroke release valve prevents cylinder extension beyond maximum height
- Smooth rolling 4 inch poly over nylon wheels, two swivel and two fixed for increased maneuverability
- Fixed rear wheels feature parking brakes for added safety
- All steel design of frame and table permit the transport of heavy materials
- Easy-to-use hydraulic foot pump for precision raising and lowering of table
- Models SLT-330F and SLT-660F feature folding handles for easy storage
- Rebuild / Repair Kits Available



"JUMBO" SCISSOR LIFT WITH EXTRA LARGE TABLE SURFACE



STOCK NO.	140771	140777	140780	140779
Model No.	SLT-330F	SLT-660F	SLT-1100	SLT-1650
Capacity (Lbs.)	330	660	1,100	1,650
Table Size (L x W) (In.)	27-1/2 x 17-3/4	32-1/2 x 19-5/8	63 x 31-1/2	39-3/8 x 20-1/8
Minimum Height (In.)	8-5/8	10-5/8	11-1/8	16
Maximum Height (In.)	28-3/4	34-1/8	36	35-5/8
Handle Height (In.)	34-1/8	40	39	40
Strokes to reach Maximum Height*	16	13	33	15
Wheel Diameter (In.)	5	5	5	5
Overall Dimensions (L x W) (In.)	36 x 17-3/4	42-1/2 x 19-5/8	73-1/2 x 31-1/2	53-1/2 x 22-3/4
Weight (Lbs.)	91	151	282	242
Rebuild / Repair Kit Stock #	SLT330FH-RK	SLT660FH-RK	SLT1100-RK	SLT1650-RK

* WITHOUT LOAD

DSLIT SERIES DOUBLE SCISSOR LIFT TABLE



FEATURES

- Overload Protection ball valve prevents lifting loads past maximum capacity
- Top-Stroke release valve prevents cylinder extension beyond maximum height
- Smooth rolling 4 inch poly over nylon wheels, two swivel and two fixed for increased maneuverability
- Fixed rear wheels feature parking brakes for added safety
- All steel design of frame and table permit the transport of heavy materials
- Easy-to-use hydraulic foot pump for precision raising and lowering of table
- Rebuild / Repair Kits Available



STOCK NO.	140778
Model No.	DSLIT-770
Capacity (Lbs.)	770
Table Size (L x W) (In.)	35-5/8 x 20-1/8
Minimum Height (In.)	13-9/16
Maximum Height (In.)	51-1/8
Handle Height (In.)	39
Strokes to reach Maximum Height*	21
Wheel Diameter (In.)	5
Overall Dimensions (L x W) (In.)	45-3/4 x 20-1/8
Weight (Lbs.)	226
Rebuild / A13:E13 Kit Stock #	DSL770-RK

* WITHOUT LOAD

STAND BEHIND YOUR WORK™

