

EcoLine Orbital riveting machines

- *attractive price*
- *simple handling*
- *fast use*
- *robust and reliable*

Optimized for profitability

Advantageous investment

The simple and functional built riveting machines with orbital technology offer an excellent price/performance value. The proved BalTec quality guarantees a long durability and a high availability.

High productivity

Easy operation and reduced personnel costs as well as short cycle times assure an efficient use.

Multipurpose design

- ENE riveting units for integrating in machines
- Complete EN workstations as stand-alone machines



EN 10



Technical specifications of the EcoLine machines

Model	EN 05	EN 10	EN 15
Rivet shank* max. Ø	5 mm	8 mm	10 mm
Rivet head** max. Ø	7 mm	12 mm	16 mm
Pneumatic pressure	2–6 bar	2–6 bar	2–6 bar
Riveting force ***	5 kN	10 kN	15 kN
Tool stroke S	0–40 mm	0–40 mm	0–40 mm
Riveting time	0.2–5.9 sec	0.2–5.9 sec	0.2–5.9 sec
Weight	88 kg	93 kg	98 kg
Weight, riveting units	21 kg	26 kg	31 kg

*Steel 370 N/mm² (St. 37), full-shank rivet **Riveting peen with flat profile ***Maximum riveting force in kN

Dimensions (mm)

Model	A	B	C	D
EN 05	58–208	100	558	706–856
EN 10	58–208	182	640	788–938
EN 15	58–208	264	722	870–1020

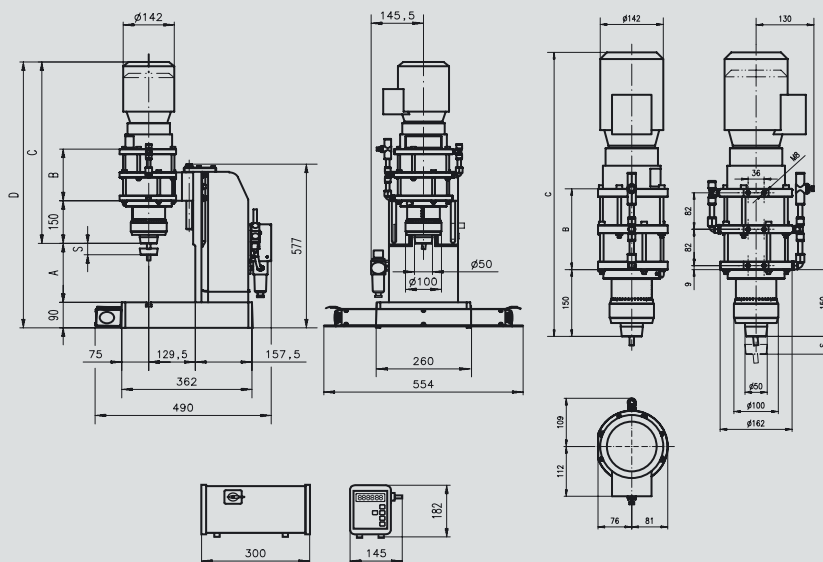

Please ask for our detailed dimensioned drawings.

Control unit

The control unit for the orbital riveting machines includes the following options:

Operating modes

- Setup mode: Riveting operation active, as long as the input is actuated
- Single cycle: Riveting operation active during the programmed riveting time

Riveting time

- adjustable between 0.2 and 5.9 seconds

Operating mode of the riveting machine motor

- Motor permanently on
- Motor only on during the riveting operation

Riveting peens for every application

The comprehensive range of riveting peens available from BalTec ensures there is a suitable riveting tool for every application.

Further information: www.baltec.com

Distributions:

Germany

BalTec Maschinenbau AG
Niederlassung Uhingen
DE-73066 Uhingen
Phone +49 (0)7161 3613 00

England/Ireland

BalTec (UK) Ltd.
Reading, Berkshire RG6, 4UT/England
Phone +44 (0)1189 311 191

USA/Canada

BalTec Corporation
Canonsburg
PA 15317 USA
Phone +1 (0)724 873 5757

France

BalTec France
FR-91070 Bondoufle
Phone +33 (0)1 69 47 12 00

Distribution partners in:

Australia	Mexico
Austria	Netherlands
Belgium	Norway
Bulgaria	Poland
China	Portugal
Columbia	Romania
Croatia	Russia
Czech Republic	Singapore
Denmark	Slovakia
Egypt	Slovenia
Finland	South Africa
Hungary	Spain
India	Sweden
Iran	Turkey
Israel	
Italy	
Japan	
Korea	
Luxembourg	
Malaysia	

Your distribution partner:

BalTec Maschinenbau AG
CH-8330 Pfäffikon
Switzerland
Phone +41 (0)44 953 13 33
Fax +41 (0)44 953 13 44
E-mail: baltec@baltec.com
Internet: www.baltec.com

BalTec