



Multi-turn gearboxes

for operation or automation of gate and globe valves

Bevel gearboxes GK 10.2 – GK 40.2

Spur gearboxes GST 10.1 – GST 40.1

Torques up to 16,000 Nm





Applications

AUMA multi-turn gearboxes are used wherever multi-turn valves have to be operated, e.g. gate valves in any possible design. They are suitable for both manually operated and motor driven valves.

Due to the large torque range available, their modular design and potential for use with electric multi-turn actuators, the gearboxes can be used for the most varied applications.



Energy

- : Power plants
- : Air pollution control
- : District heating
- : Pipelines



Water/Wastewater

- : Water works
- : Sewage treatment plants
- : Pumping stations
- : Dams



Chemical industry

- : Chemical industry
- : Petrochemical industry
- : Pharmaceutical industry



Others

- : Oil and gas industry
- : Air conditioning
- : Ship building industry
- : Steel mills
- : Cement plants
- : Food industry

Table of contents	
Modular design – versions	4
Summary of applications, functions, and equipment	6
Design principle	7
Service conditions	8
Functions	10
Signals	13
Indication	14
Valve attachment	15
Technical data	16
Certificates	18
Literature	19
The actuator specialist	20
Index	21
AUMA worldwide	22

Solutions for a world in motion

This brochure will provide both beginners and experts with a perfect overview of the functions and applications of AUMA GK and GST multi-turn gearboxes. It can be used as the basis to determine whether a device is suitable for the chosen application.

For detailed product selection refer to the separate data sheets and price lists. On request, AUMA engineers within field service and within our subsidiaries can help you to find the correct device for the application.

AUMA valve gearboxes are renowned for their outstanding reliability and long service life. A sophisticated design and the use of first grade materials ensure long-term and virtually maintenance-free operation.

The latest detailed information on the GK and GST multi-turn gearboxes can be found on the Internet under www.auma.com. All documents, including dimensional drawings, wiring diagrams and final inspection records for supplied gearboxes are available on the Internet in a digital form.

Subject to change without notice.

The product features and technical data provided do not express or imply any warranty.

Modular design/versions

Modular concept - manual or motor operation

Depending on the application, gate valves and globe valves with diameters ranging from a few centimetres to several metres are to be opened or closed and controlled either manually or electrically.

AUMA meets the various requirements with their flexible and modular product range. The GK and GST multi-turn gearboxes offer a number of adaptation possibilities due to their variability. Moreover, they can easily be combined with other AUMA products.

Manual operation

For manually operated gate and globe valves with high torque requirements you need a gearbox for manual valve operation. The reduction ratio within the gearing reduces the required rim pull. Handwheels with various diameters enable adaptation of the gearboxes to your particular requirements.

Motor operation

Combining one or several AUMA multi-turn gearboxes with an AUMA SA range multi-turn actuator expand the potential for optimum valve automation. On the one hand, the gear reduction ratio allows using smaller and thus more economically priced multi-turn actuators and on the other hand, solutions for special applications can be implemented, e.g. automating a double-stem gate valve.

SA multi-turn actuators are also available in explosion-proof version. Consequently, GK and GST gearboxes are also approved for the use in potentially explosive atmospheres.

Please refer to the product description on multi-turn actuators for open-close and modulating duty for further actuator information.

Shutting off, positioning, controlling

The duty type is an important selection criteria for gearboxes used in combination with a multi-turn actuator. Is the valve to be used as a shut-off device (open-close duty), is the valve to be positioned in mid-travel (positioning mode) or is the valve a control valve where the valve position is to be changed at short intervals, i.e. to control the flow through a pipeline (modulating duty)? These are essential factors for sizing the valve, but also for actuator and gearbox as the load may vary considerably depending on the operation mode.

AUMA GK and GST multi-turn gearboxes are suitable for open-close and positioning duty, up to sizes GK 30.2 or GST 30.1 and also for modulating duty.



[1]



[3]



[5]



[2]



[4]



[6]

[1] GK bevel gearbox with handwheel

[2] GST spur gearbox with handwheel

The designations bevel gearbox or spur gearbox refer to the gearbox design principle.

[3] Multi-turn actuator/bevel gearbox combination SA/GK

[4] Multi-turn actuator/spur gearbox combination SA/GST

Torques up to 16,000 Nm

Contrary to the version for manual operation, the gearbox input includes a mounting flange for the actuator. The multi-turn actuator is mounted with a screw connection to the gearbox which can easily be removed for maintenance purposes. The flange connection between multi-turn actuator and gearbox meets the requirements of EN ISO 5210 or DIN 3210 as an alternative.

[5] Stem protection tube

Gate valves often have rising stems. You may equip the gearbox with a stem protection tube. The tube protects the stem from soiling and climatic influences and avoids any danger of injury.

Stem protection tubes in various lengths are not only available for the illustrated GST spur gearbox but also for the GK bevel gearbox.

[6] Reversal of rotation direction

is achieved by an intermediate GW reversing gearbox. The reversing gearbox is mounted between the multi-turn actuator and the GK bevel gearbox or the GST spur gearbox. The GW is a simple option to automate a counterclockwise closing valve with a standard clockwise closing multi-turn actuator.

Summary of applications, functions, and equipment

Standard ● Option ■	GK 10.2 – GK 40.2	GST 10.1 – GST 40.1	Page
Applications/duty types			
Manual operation	●	●	4
Motor operation	■	■	4
Open-close duty	●	●	4
Positioning duty	●	●	4
Modulating duty	■	■	4
Service conditions			
Enclosure protection IP 67	●	●	8
Enclosure protection IP 68	■	■	8
High temperature version	■	■	8
Low temperature version	■	■	8
Corrosion protection KN	●	●	9
Corrosion protection KS, KX	■	■	9
Explosion protection	■	■	9
Functions			
Reduction of input torques	●	●	10
Adaptations to special mounting conditions	●	●	11
Automating double-stem gate valves	●	–	11
Protection against accidental changing of the valve position	●	●	12
Feedback signals			
Valve end positions	■	■	13
Valve position	■	■	13
Local indication			
Valve end positions	●	●	14
Valve position	●	●	14
Valve is running	●	●	14
Valve attachment according to EN ISO 5210/DIN 3210			
Output drive types B, B1	●	●	15
A, B2, B3, B3D, B4, C, D, DD, E	■	■	15
Special output drives	■	■	15

Design principle

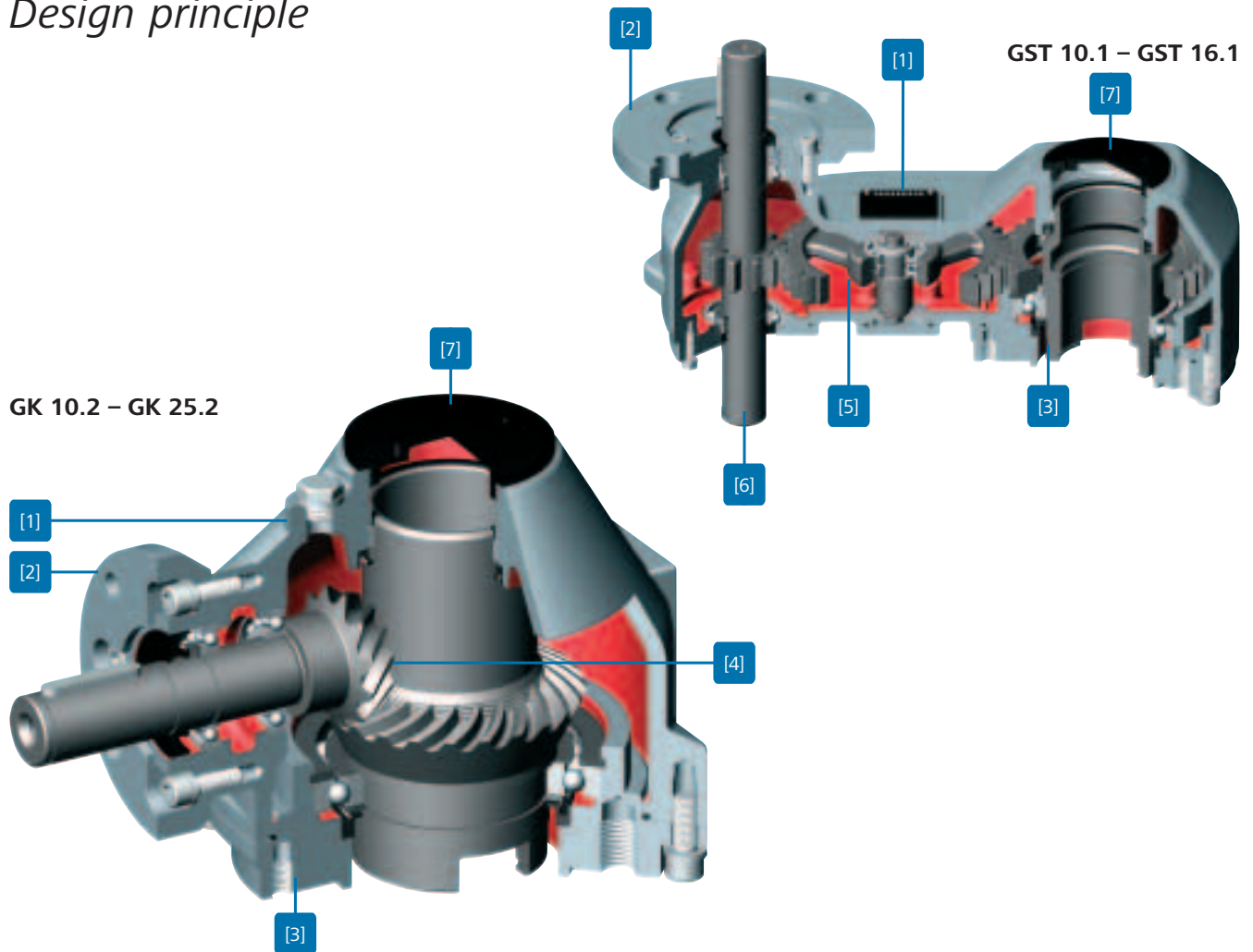

[1] Housing

In its basic version, the housing is made of cast iron. A housing made of spheroidal cast iron can be used if it is likely to be exposed to extreme external loads, e.g. in seismic areas.

[2] Flange for mounting a multi-turn actuator

The flange sizes are according to EN ISO 5210 (optional DIN 3210).

Manually operated gearboxes are not equipped with a flange for actuator. A handwheel is fitted on their input shaft. Various handwheel diameters are available.

[3] Valve attachment

The mounting flange is according to EN ISO 5210 or DIN 3210. Various output drive types are available. Therefore it is possible to adapt to different types of valves. For further information refer to page 15.

[4] Bevel gear

Within a single stage, this type of gear adjusts the effective direction of the input torque by 90°. Ideal for actuating valves where access is difficult (in combination with an AUMA SA multi-turn actuator).

[5] Spur gear

This gear type is easy to install and of robust and cost-effective design. A small actuator and spur gearbox combination is often less expensive than a larger multi-turn actuator. It has to be verified whether the increased operating time caused by the additional reduction is acceptable. The combination between spur gearbox and multi-turn actuator offers a space-saving advantage as the actuator mounting position can be shifted by the distance between gearbox input flange and output drive flange. Providing a solution for your specific installation requirement.

[6] Free shaft end

In case of unfavourable space conditions where direct mounting of the multi-turn actuator is not possible, the input torque may also be supplied via a shaft with universal joint at the free shaft end.

[7] Screw plug

The screw plug prevents the ingress of dust and humidity. For rising stems with large stroke, the screw plug is replaced by a stem protection tube or a telescopic protection tube (refer to pages 5 and 14).

Service conditions

AUMA devices are used worldwide; in all climate zones, in industrial plants of all kinds under special local ambient conditions. AUMA devices have to operate reliably and for a long time under any conditions without requiring major maintenance work. For this very reason, AUMA has focussed on making AUMA devices resistant to the most unfavourable conditions and have adapted their protective measures to the state-of-the-art technology.



AUMA multi-turn actuators SA in combination with spur gearboxes in Siberia.

Enclosure protections

IP 67

AUMA bevel and spur gearboxes conform to enclosure protection IP 67 according to EN 60 529. IP 67 means protection against immersion up to max. 1 m head of water for max. 30 minutes.

IP 68

Upon request, AUMA bevel and spur gearboxes are available with improved enclosure protection IP 68 according to EN 60 529. IP 68 means protection against submersion up to 6 m head of water.

Ambient temperatures

Versions	Temperature range ¹
Standard	- 25 °C ... + 80 °C
High temperature	0 °C ... + 120 °C
Low temperature	- 40 °C ... + 60 °C
Extreme low temperature	- 60 °C ... + 60 °C

¹ If a gearbox is used in combination with a multi-turn actuator, observe the admissible temperature range of the multi-turn actuator.

Corrosion protection/colour

Standard (KN)

The standard AUMA corrosion protection KN is a high quality coating. This is suitable for outdoor installation and for slightly aggressive atmospheres with a low level of pollution.

KS

AUMA recommends this corrosion protection class for installation in occasionally or permanently aggressive atmospheres with a moderate pollutant concentration.

KX

AUMA recommends this corrosion protection class for installation in aggressive atmosphere with high humidity and a high pollutant concentration.

Colour

The standard colour of the finish coating is silver-grey (similar to RAL 3037). Other colours are available on request.

Explosion protection

For the installation of valve gearboxes in potentially explosive atmospheres, special protective measures are required.

AUMA gearboxes are approved for installation in potentially explosive zones.

They comply with the regulations stipulated in European standard EN 13463-1 et seqq. AUMA certifies this in a declaration of incorporation.

Classification of explosion protection

- II2G c IIC T4 according to ATEX 94/9/EC

Functions

It seems somewhat overdone to talk about features when considering gearboxes with a relatively basic design. In particular when using gearboxes with manually operated valves, the operation task is limited to providing a reduced rim pull. However, the gearbox characteristics may not be considered alone. Customised automation solutions can be implemented when combining the gearboxes with AUMA multi-turn actuators.

Reduction of input torques

If the valve requires manual operation, the applicable rim pull should not exceed the limits stipulated in EN 12 750. These limit values can be met when using a GK or GST gearbox.

For the automation of gate valves, you require a multi-turn actuator. The combination of a multi-turn actuator and a multi-turn gearbox is often more cost-effective than a large multi-turn actuator. This effect is particularly noticeable when applying larger torques.

It has to be verified whether the increased operation time caused by the additional reduction is acceptable.



Bevel gearbox for manual valve operation in a Vietnamese sewage plant

Adaptations to special mounting conditions

GK bevel gearboxes and GST spur gearboxes with a reduction ratio 1:1 are available for smaller torques up to 120 Nm, to find a solution for special installation applications.

The GST gearbox shifts the multi-turn actuator out of the valve stem axis. In the case of restricted access, this option allows free access to the actuator handwheel. Depending on the conditions on site, the GK might turn out to be the ideal solution. You may also combine GK and GST gearboxes or align several GK gearboxes one after the other. This multiplies the possible solutions.

Automating double-stem gate valves

Double-stem gate valves are typically used in hydraulic steelwork industries. For these valves it is of utmost importance to operate both stems simultaneously to avoid jamming the plate.

The combination of an SA multi-turn actuator and two GK bevel gearboxes ensure the required synchronisation. A GK is mounted to each of the stem ends. The SA actuator is directly mounted to one of the two GK gearboxes; the second gearbox is driven via a second output shaft on the multi-turn actuator.



Five manually operated gate valves equipped with GST spur gearboxes and a gate valve automated with an AUMA multi-turn actuator in a heating power station



Several double-stem gate valves in a sewage treatment plant

Functions

Protection against accidental changing of the valve position

Gravity, vibration or forces acting upon the medium within a pipeline may lead to accidental changes in the valve position. This has to be prevented.

Self-locking

The self-locking feature prevents the valve position from being changed from standstill when forces act upon the valve output drive

Due to their design, AUMA GK bevel and GST gearboxes are not self-locking. Self-locking can be achieved by mounting an LMS anti-backdrive device.

Self-braking

If the valve is effectively brought to a standstill after operation, this is called self-braking. The braking torque of the gearbox or the actuator/gearbox combination must correspond to at least the maximum output torque.

This requirement can also be met by using an anti-backdrive device.

Anti-backdrive device

By using an LMS 07.1 – LMS 16.1 anti-backdrive device, both self-locking and self-braking can be achieved. The retaining or braking torque of the combination between anti-backdrive device and gearbox corresponds to at least the maximum output torque of the gearbox.

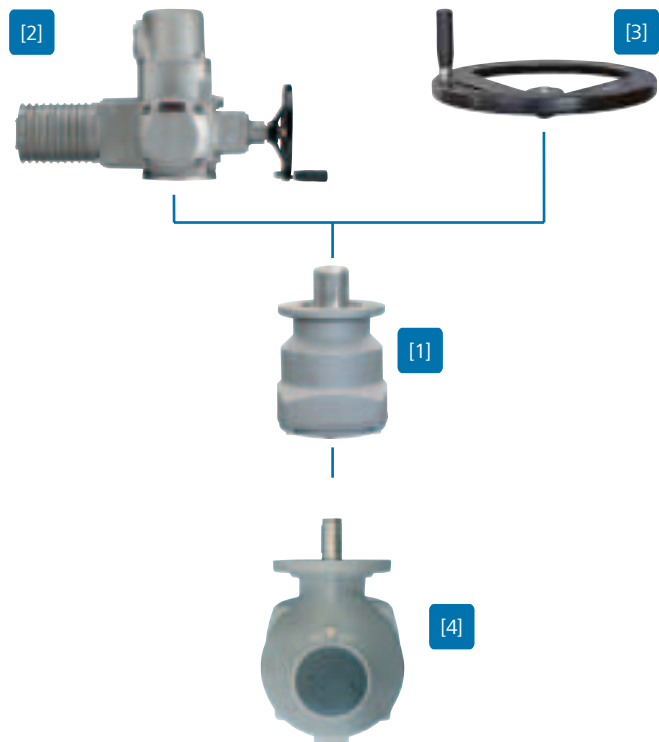

The anti-backdrive device [1] can be used for motor-operated and manually operated valves. Therefore a multi-turn actuator [2] or a handwheel [3] is mounted at the input flange of the anti-backdrive device.

Apart from small sizes, the anti-backdrive device is mounted at the input flange of a GK bevel gearbox [4] or a GST spur gearbox. Only the comparatively low input torque acts on the anti-backdrive device, not the high output torque. Consequently, the braking effect of the anti-backdrive device is amplified by the amount of the reduction ratio of the gearbox.

Signals

Signals are the foundation for controlling a process flow. Manually operated valves can also provide feedback signals if equipped accordingly.

For gearboxes used in combination with a multi-turn actuator, the actuator generally performs the task of supplying the DCS with the required feedback signals.

Feedback signals

In order to provide a DCS with information on the valve position, the manually operated GK or GST multi-turn gearboxes can be equipped with a WSH limit switching device.

The WSH is mounted on the gearbox input flange. The complete torque range relevant to manually operated valves is covered by the three sizes WSH 10.1, WSH 14.1, and WSH 16.1.

Valve end position

The integral end position switches signal that a valve end position has been reached.

Valve position

An optional position transmitter can provide the DCS with the valve position either as a voltage signal or as a 0/4 – 20 mA current signal.

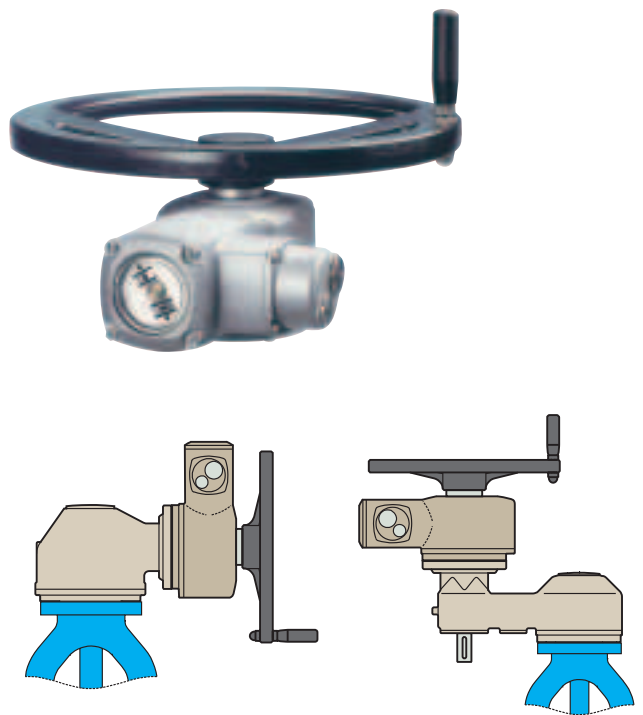

GK bevel gearbox with WSH (left) and GST spur gearbox with WSH (right)

Indication

Depending on the installed location it is not always possible to identify the valve position on site. Many applications require that the valve position is displayed locally.

Position indicator

Many gate valves are equipped with a rising stem moving upward or downward during operation. Therefore, the stem position follows the valve position. Generally, the stem runs hidden within a stem protection tube mounted to the GK or GST gearbox which avoids any personal damage and prevents the stem from being soiled by ingress of dirt.

As an option, the stem protection tube can be replaced by a telescopic protection tube. This tube changes its length with the stem and is therefore suitable for valve position indication.

By fixing a marker on the telescopic protection tube you may recognise whether the valve is in an end position or an intermediate position.



If the gearbox is equipped with a WSH limit switching device (refer to page 13), you may read the valve position on the WSH position indication.

Valve attachment

The gearboxes are mounted to the valve using a mounting flange standardised according to EN ISO 5210 or DIN 3210.

The output drive types are also manufactured according to these standards. They establish the mechanical connection between the output drive of the gearbox and the valve stem or the valve shaft. The torque is transmitted from the gearbox to the valve using this connection. There are various output drive types available for different valve types. The most common output drive types are illustrated below.

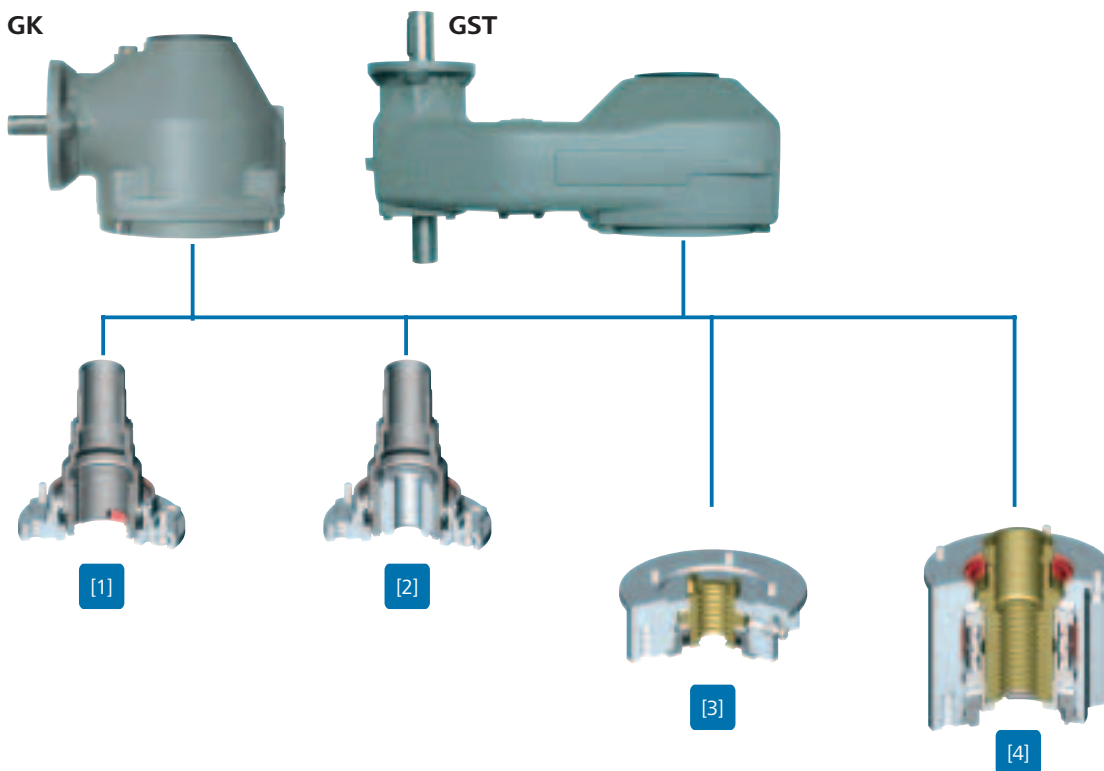

[1] Output drive types B1, B2 (EN ISO 5210), or B (DIN 3210)

This output drive is integrated into the hollow shaft of the gearbox. The torque is transmitted via a parallel key. Low radial loads can be accepted.

[2] Output drive types B3 or B4 (EN ISO 5210), or E (3210)

The torque is transmitted via a parallel key. By using a plug sleeve, output drive type B1 can easily be converted to output drive types B3 or B4.

[3] Output drive type A (EN ISO 5210/DIN 3210)

Stem nut for rising and non-rotating valve stem. The mounting flange together with the stem nut and thrust bearings form an assembly, which is suitable for accepting thrust. The unit is screwed to the gearbox. Output drive type A cannot accept any radial loads.

[4] Output drive type AF (EN ISO 5210/DIN 3210)

Spring-loaded stem nut for rising and non-rotating valve stems. The springs compensate for dynamic thrust at high speeds or even for thermal expansion of the valve stem. The torque transmission is supplied via internal teeth.

[5] Special output drive types (without illustration)

Further output drive types are available besides those described:

- Pendulum stem nut AK
- Stem nut with plain bearings AG
- Hexagon in hollow shaft
- Insulated output drives IB1 and IB3

For detailed information on special output drive types, refer to separate data sheets and price lists.

Technical data

Bevel gearboxes GK 10.2 – GK 40.2

For detailed data refer to the separate technical data sheets.

Type	Output torque		Reduction ratio	Input torque		Valve attachment	
	Nominal torque max. [Nm]	Torque for modulating max. [Nm]		Nominal torque [Nm]	Torque for modulating [Nm]	Standard EN ISO 5210	Option DIN 3210
GK 10.2	120	60	1 : 1 2 : 1	135 67	66 33	F10	G0
GK 14.2	250	120	2 : 1 2.8 : 1	139 100	66 48	F14	G1/2
GK 14.6	500	200	2.8 : 1 4 : 1	198 139	80 55	F14	G1/2
GK 16.2	1,000	400	4 : 1 5.6 : 1	278 198	111 80	F16	G3
GK 25.2	2,000	800	5.6 : 1 8 : 1	397 278	160 111	F25	G4
GK 30.2	4,000	1,600	8 : 1 11 : 1	556 404	222 162	F30	G5
GK 35.2	8,000	–	11 : 1 16 : 1	808 556	–	F35	G6
GK 40.2	16,000	–	16 : 1 22 : 1	1,111 808	–	F40	G7

Spur gearboxes GST 10.1 - GST 40.1

For detailed data refer to the separate technical data sheets.

Typ	Output torque		Reduction ratio	Input torque		Valve attachment	
	Nominal torque max. [Nm]	Torque for modulating max. [Nm]		Nominal torque [Nm]	Torque for modulating [Nm]	Standard EN ISO 5210	Option DIN 3210
GST 10.1	120	60	1 : 1 1.4 : 1 2 : 1	135 95 67	66 46 33	F10	G0
GST 14.1	250	120	1.4 : 1 2 : 1 2.8 : 1	198 139 100	92 66 48	F14	G1/2
GST 14.5	500	200	2 : 1 2.8 : 1 4 : 1	278 198 139	111 80 55	F14	G1/2
GST 16.1	1,000	400	2.8 : 1 4 : 1 5.6 : 1	397 278 198	160 111 80	F16	G3
GST 25.1	2,000	800	4 : 1 5.6 : 1 8 : 1	556 397 278	222 160 111	F25	G4
GST 30.1	4,000	1 600	5.6 : 1 8 : 1 11 : 1	794 556 404	320 222 162	F30	G5
GST 35.1	8,000	–	8 : 1 11 : 1 16 : 1	1,111 808 556	–	F35	G6
GST 40.1	16,000	–	11 : 1 16 : 1 22 : 1	1,616 1,111 808	–	F40	G7

Possible combinations with multi-turn actuators

For detailed data refer to the separate technical data sheets.

GK bevel gearboxes with multi-turn actuators SA

Gearbox	Suitable AUMA multi-turn actuator	
	Open-close duty	Modulating duty
GK 10.2	SA 07.5; SA 10.1; SA 14.1	SAR 07.5; SAR 10.1; SAR 14.1
GK 14.2	SA 10.1; SA 14.1	SAR 10.1; SAR 14.1
GK 14.6	SA 10.1; SA 14.1	SAR 10.1; SAR 14.1
GK 16.2	SA 14.1; SA 14.5	SAR 14.1
GK 25.2	SA 14.1; SA 14.5	SAR 14.1; SAR 14.5
GK 30.2	SA 14.5; SA 16.1	SAR 14.5; SAR 16.1
GK 35.2	SA 14.5; SA 16.1	–
GK 40.2	SA 16.1; SA 25.1	–

GST spur gearboxes with multi-turn actuators SA

Gearbox	Suitable AUMA multi-turn actuator	
	Open-close duty	Modulating duty
GST 10.1	SA 07.5; SA 10.1; SA 14.1	SAR 07.5; SAR 10.1; SAR 14.1
GST 14.1	SA 10.1; SA 14.1	SAR 10.1; SAR 14.1
GST 14.5	SA 10.1; SA 14.1; SA 14.5	SAR 10.1; SAR 14.1
GST 16.1	SA 14.1; SA 14.5	SAR 14.1; SAR 14.5
GST 25.1	SA 14.1; SA 14.5; SA 16.1	SAR 14.1; SAR 14.5; SAR 16.1
GST 30.1	SA 14.5; SA 16.1	SAR 14.5; SAR 16.1
GST 35.1	SA 14.5; SA 16.1; SA 25.1	–
GST 40.1	SA 16.1; SA 25.1	–

Lifetime of gearboxes in open-close duty

An operation cycle is based on an operation from CLOSED to OPEN and back to CLOSED, with a travel of 30 turns per stroke.

Gearbox		Operating cycles
GK 10.2	GST 10.1	20,000
GK 14.2	GST 14.1	15,000
GK 14.6	GST 14.5	15,000
GK 16.2	GST 16.1	15,000
GK 25.2	GST 25.1	10,000
GK 30.2	GST 30.1	10,000
GK 35.2	GST 35.1	5,000
GK 40.2	GST 40.1	5,000

Lifetime of gearboxes in modulating duty

The lifetime depends on the load and the number of starts. A high starting frequency will rarely improve the modulating accuracy. To reach the longest possible maintenance and fault-free operation time, the number of starts per hour chosen should be as low as possible for the process. This can be achieved by setting the modulating parameters accordingly.

Gearbox		Modulating steps
GK 10.2	GST 10.1	5.0 million
GK 14.2	GST 14.1	3.5 million
GK 14.6	GST 14.5	3.5 million
GK 16.2	GST 16.1	3.5 million
GK 25.2	GST 25.1	2.5 million
GK 30.2	GST 30.1	2.5 million

Certificates

EU directives

Declaration of incorporation in accordance with Machinery Directive

According to this EU directive, AUMA actuators, actuator controls and valve gearboxes are not complete machines. This means that a Declaration of conformity in accordance with the Machinery Directive cannot be issued by AUMA. AUMA's Declaration of Incorporation confirms that during the design stage of the devices, the standards mentioned in the Machinery Directive were applied. The Declarations of Incorporation are included in the operation instructions of the devices.

Only by mounting the devices to other components (valves, pipelines etc.) a 'machine' within the meaning of the directive is formed. Before commissioning this machine a Certificate of Conformity must be issued.

ATEX Directive

The fulfilment of requirements for gearboxes has been proven in internal tests and inspections. AUMA has issued declaration of conformity certifying the compliance.

Compulsory marking with CE mark

AUMA products meet the requirements of the mentioned EU directives. The name plate is therefore marked with the CE mark.



Final inspection record

After assembly all gearboxes are thoroughly tested according to AUMA's inspection specification. The procedure is recorded on the final inspection record.

Where can I get the certificates?

All certificates and records are provided by AUMA on request either as a hard or digital copy.

The documents can be downloaded from the AUMA website around the clock; some of them are password protected.

- www.auma.com

Literature

Further literature

Brochures

- Information
Electric actuators and valve gearboxes according to ATEX directive 94/9/EC for the use in potentially explosive atmospheres
- Product description
Electric multi-turn actuators for open-close and modulating duty

Technical data

- Bevel gearboxes GK 10.2 – GK 40.2
- Spur gearboxes GST 10.1 – GST 40.1
- Furthermore, there are dimension sheets available.

The latest issues of all documentation can be downloaded as PDF files from www.auma.com.

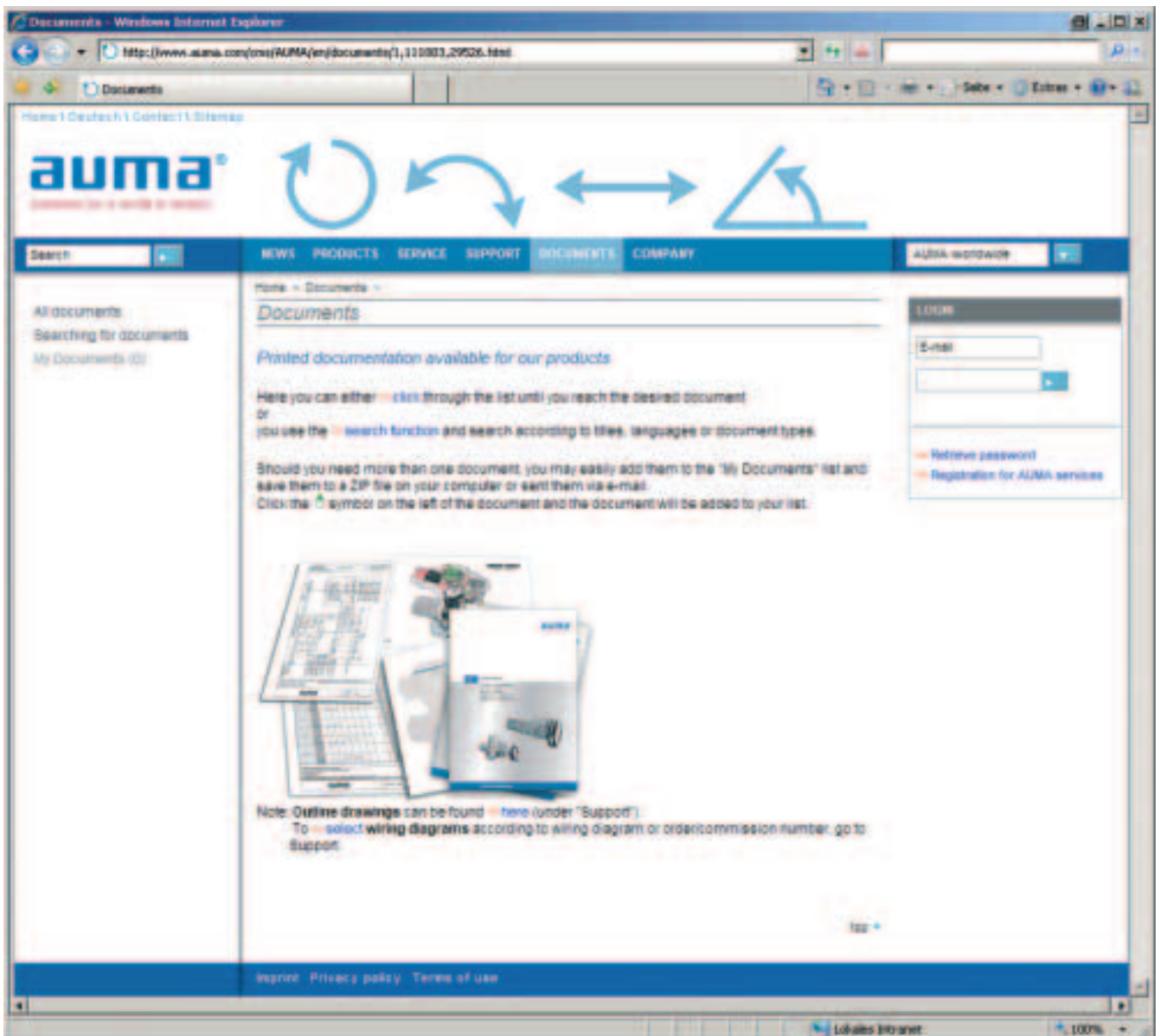

The actuator specialist

At AUMA, everything revolves around the electric actuator. In a world where industrial processes have become increasingly complex, concentration is an asset – while still being able to see the bigger picture.

AUMA has to cope with a multitude of requirements from the most different applications and from every corner of the world - this is our daily business. We rise to this challenge by pursuing a clear but flexible product policy – supplying the ideal actuator to every customer.

For this purpose, you have to know your markets. Thinking globally means acting regionally. A comprehensive worldwide sales and service network ensures that there is a competent local contact for every customer.

Since 1964, AUMA has established an excellent brand name in the world of actuators. Reliability and innovation are concepts which are closely linked with AUMA. This is above all to be credited to AUMA's dedicated employees who work enthusiastically on the future of the actuator.



Quality is not just a matter of trust

Actuators must be reliable and dependable. They determine the cycle of accurately defined work processes.

But reliability does not begin during commissioning. It begins with a well thought out design and careful selection of materials. This continues with conscientious production using ultra-modern machinery in clearly controlled and supervised steps, while keeping in mind the environment.

At AUMA, quality management is monitored on a daily basis. Numerous customer and independent audits, backed by ISO 9001 and ISO 14001 certification confirm these high standards.



Index

A

Ambient temperatures 8

Anti-backdrive device 12

B

Bevel gear 7

C

CE mark 18

Certificates 18

Colour 9

Corrosion protection 9

D

Double-stem gate valve 11

E

Enclosure protection IP 8

EU directives 18

Explosion protection 9

F

Feedback signals 13

Functional test 18

H

Housing 7

I

Indication 8

L

Lifetime 17

Limit switching 13

Literature 19

M

Manual operation 4

Modulating duty 4

Motor operation 4

Multi-turn actuator 7

O

Open-close duty 4

Output drive type 15

P

Painting 9

Plug sleeve 15

R

Reversal of rotation direction 5

S

Screw plug 14 7

Self-braking 12

Self-locking 17 12

Signals 13 13

Spur gear 19 7

Stem protection tube 5

T

Telescopic protection tube 4 14

Torque 4 16

V

Valve attachment 7,15

Valve end position 13 - 14

Valve position 13 - 14

Europe

AUMA Riester GmbH & Co. KG

Plant Müllheim
DE-79373 Müllheim
Tel +49 7631 809 - 0
riester@auma.com
www.auma.com

Plant Ostfildern-Nellingen
DE-73747 Ostfildern
Tel +49 711 34803 - 0
riester@wof.auma.com

Service Center Cologne
DE-50858 Köln
Tel +49 2234 2037 - 9000
Service@sck.auma.com
Service Center Magdeburg
DE-39167 Niederndodeleben
Tel +49 39204 759 - 0
Service@scm.auma.com
Service Center Bavaria
DE-85386 Eching
Tel +49 81 65 9017- 0
Riester@scb.auma.com

AUMA Armaturentriebe GmbH
AT-2512 Tribuswinkel
Tel +43 2252 82540
office@auma.at
www.auma.at

AUMA (Schweiz) AG
CH-8965 Berikon
Tel +41 566 400945
RettichP.ch@auma.com

AUMA Servopohony spol. s.r.o.
CZ-10200 Praha 10
Tel +420 272 700056 / 704125
auma-s@auma.cz
www.auma.cz

OY AUMATOR AB
FI-02230 Espoo
Tel +358 9 5840 22
auma@aumator.fi
www.aumator.fi

AUMA France S.A.R.L.
FR-95157 Taverny Cedex
Tel +33 1 39327272
info@auma.fr
www.auma.fr

AUMA ACTUATORS Ltd.
GB- Clevedon North Somerset BS21 6QH
Tel +44 1275 871141
mail@auma.co.uk
www.auma.co.uk

AUMA ITALIANA S.r.l. a socio unico
IT-20023 Cerro Maggiore (MI)
Tel +39 0331 51351
info@auma.it
www.auma.it

AUMA BENELUX B.V.
NL-2314 XT Leiden
Tel +31 71 581 40 40
office@benelux.auma.com
www.auma.nl

AUMA Polska Sp. z o.o.
PL-41-310 Dabrowa Górnicza
Tel +48 32 261 56 68

R.Ludzien@auma.com.pl
www.auma.com.pl

OOO Priwody AUMA
RU-141400 Moscow region
for mail: 124365 Moscow a/ya 11
Tel +7 495 221 64 28
aumarussia@auma.ru
www.auma.ru

ERICH'S ARMATUR AB
SE-20039 Malmö
Tel +46 40 311550
info@erichsarmatur.se
www.erichsarmatur.se

GRØNBECH & SØNNER A/S
DK-2450 København SV
Tel +45 33 26 63 00
GS@g-s.dk
www.g-s.dk

IBEROPLAN S.A.
ES-28027 Madrid
Tel +34 91 3717130
iberoplan@iberoplan.com

D. G. Bellos & Co. O.E.
GR-13671 Acharnai Athens
Tel +30 210 2409485
info@dgbellos.gr

SIGURD SØRUM A. S.
NO-1300 Sandvika
Tel +47 67572600
post@sigurd-sorum.no

INDUSTRA
PT-2710-297 Sintra
Tel +351 2 1910 95 00
jpalhares@tyco-valves.com

MEGA Endüstri Kontrol Sistemleri Tic. Ltd. Sti.
TR-06810 Ankara
Tel +90 312 217 32 88
megaendustri@megaendustri.com.tr

CTS Control Limited Liability Company
UA-02099 Kiyiv
Tel +38 044 566-9971, -8427
v_polyakov@cts.com.ua

Africa

AUMA South Africa (Pty) Ltd.
ZA-1560 Springs
Tel +27 11 3632880
aumasa@mweb.co.za

A.T.E.C.
EG- Cairo
Tel +20 2 23599680 - 23590861
atec@intouch.com

America

AUMA ACTUATORS INC.
US-PA 15317 Canonsburg
Tel +1 724-743-AUMA (2862)
mailbox@auma-usa.com
www.auma-usa.com

AUMA Chile Respresentative Office
CL-9500414 Buin
Tel +56 2 821 4108
aumachile@adsl.tie.cl

LOOP S. A.
AR-C1140ABP Buenos Aires
Tel +54 11 4307 2141
contacto@loopsa.com.ar

Asvotec Termoindustrial Ltda.
BR-13190-000 Monte Mor/ SP.
Tel +55 19 3879 8735
atuador.auma@asvotec.com.br

TROY-ONTOR Inc.
CA-L4N 5E9 Barrie Ontario
Tel +1 705 721-8246
troy-ontor@troy-ontor.ca

MAN Ferrostaal de Colombia Ltda.
CO- Bogotá D.C.
Tel +57 1 401 1300
dorian.hernandez@manferrostaal.com
www.manferrostaal.com

PROCONTIC Procesos y Control Automático
EC- Quito
Tel +593 2 292 0431
info@procontic.com.ec

IESS de Mexico, S.A. de C.V.
MX-C.P. 02900 Mexico D.F.
Tel +52 55 55 56 1701
informes@iess.com.mx

Corsusa International S.A.C.
PE- Miraflores - Lima
Tel +511444-1200 / 0044 / 2321
corsusa@corsusa.com
www.corsusa.com

PASSCO Inc.
PR-00936-4153 San Juan
Tel +18 09 78 77 20 87 85
Passco@prtc.net

Suplibarca
VE- Maracaibo Estado, Zulia
Tel +58 261 7 555 667
suplibarca@intercable.net.ve

Asia

AUMA Actuators (Tianjin) Co., Ltd.
CN-300457 Tianjin
Tel +86 22 6625 1310
mailbox@auma-china.com
www.auma-china.com

AUMA (INDIA) PRIVATE LIMITED
IN-560 058 Bangalore
Tel +91 80 2839 4655
info@auma.co.in
www.auma.co.in

AUMA JAPAN Co., Ltd.
JP-210-0848 Kawasaki-ku,
Kawasaki-shi Kanagawa
Tel +81 44 329 1061
mailbox@auma.co.jp
www.auma.co.jp

AUMA ACTUATORS (Singapore) Pte Ltd.
SG-569551 Singapore
Tel +65 6 4818750
sales@auma.com.sg
www.auma.com.sg

Al Ayman Industrial. Eqpts
AE- Dubai
Tel +971 4 3682720
auma@emirates.net.ae

PERFECT CONTROLS Ltd.
HK- Tsuen Wan, Kowloon
Tel +852 2493 7726
joeip@perfectcontrols.com.hk

DW Controls Co., Ltd.
KR-153-803 Seoul Korea
Tel +82 2 2113 1100
sichoi@actuatorbank.com
www.actuatorbank.com

Al-Arfaj Engineering Co WLL
KW-22004 Salmiyah
Tel +965 481-7448
info@arfajengg.com
www.arfajengg.com

Petrogulf W.L.L
QA- Doha
Tel +974 4350 151
pgulf@qatar.net.qa

Sunny Valves and Intertrade Corp. Ltd.
TH-10120 Yannawa Bangkok
Tel +66 2 2400656
sunnyvalves@inet.co.th
www.sunnyvalves.co.th/

Top Advance Enterprises Ltd.
TW- Jhonghe City Taipei Hsien (235)
Tel +886 2 2225 1718
support@auma-taiwan.com.tw
www.auma-taiwan.com.tw

Australia

BARRON GJM Pty. Ltd.
AU-NSW 1570 Artarmon
Tel +61 294361088
info@barron.com.au
www.barron.com.au

[1] Multi-turn actuators
SA 07.1 – SA 48.1
Torques from 10 to 32,000 Nm
Output speeds from 4 to 180 rpm

[2] Multi-turn actuators SA/SAR
with controls AUMATIC
Torques from 10 to 1,000 Nm
Output speeds from 4 to 180 rpm

[3] Linear actuators SA/LE
Combination of multi-turn actuator SA
with linear thrust unit LE
Thrusts from
4 kN to 217 kN
Strokes up to 500 mm
Linear speeds
from 20 to 360 mm/min

[4] Part-turn actuators
SG 05.1 – SG 12.1
Torques from 100 to 1,200 Nm
Operating times for 90° from 4 to 180 s

[5] Part-turn actuators SA/GS
Combination of multi-turn actuator SA with
part-turn gearbox GS
Torques up to 675,000 Nm

[6] Bevel gearboxes
GK 10.2 – GK 40.2
Torques up to 16,000 Nm

[7] Spur gearboxes
GST 10.1 – GST 40.1
Torques up to 16,000 Nm

[8] Worm gearboxes with base and lever
GF 50.3 – GF 250.3
Torques up to 32,000 Nm

AUMA Riester GmbH & Co. KG

P.O.Box 1362
D-79379 Muellheim
Tel +49 7631-809-0
Fax +49 7631-809-1250
riester@auma.com

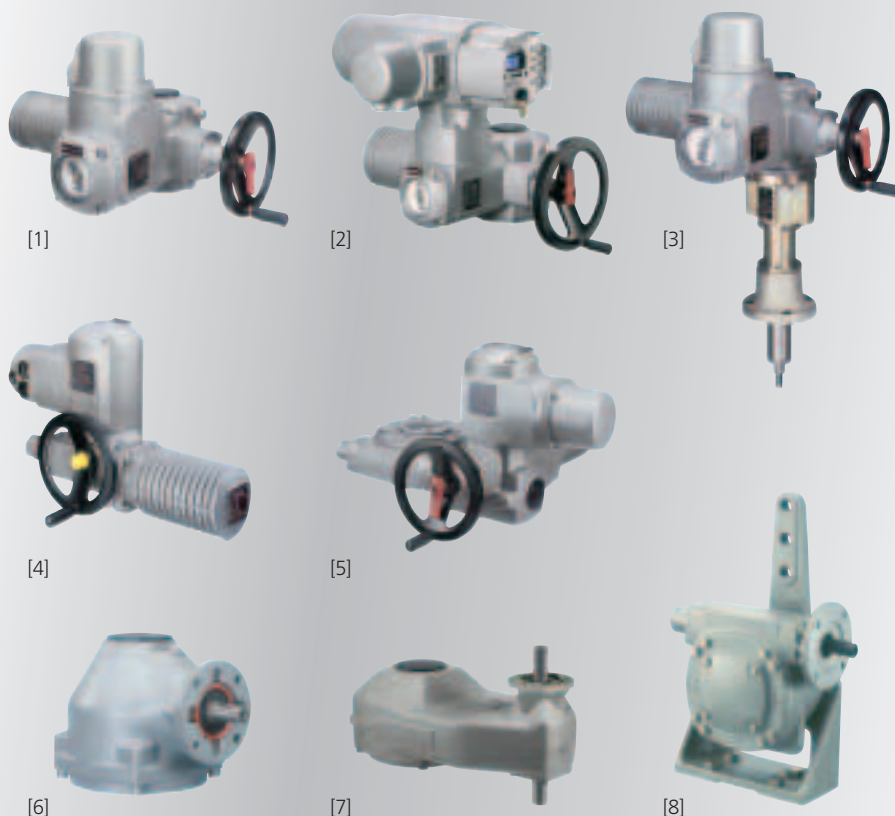

Subject to change without notice.
The product features and technical data provided do not express or imply any warranty.
Y003.769/002/en/1.07

