

*CNC Robots*

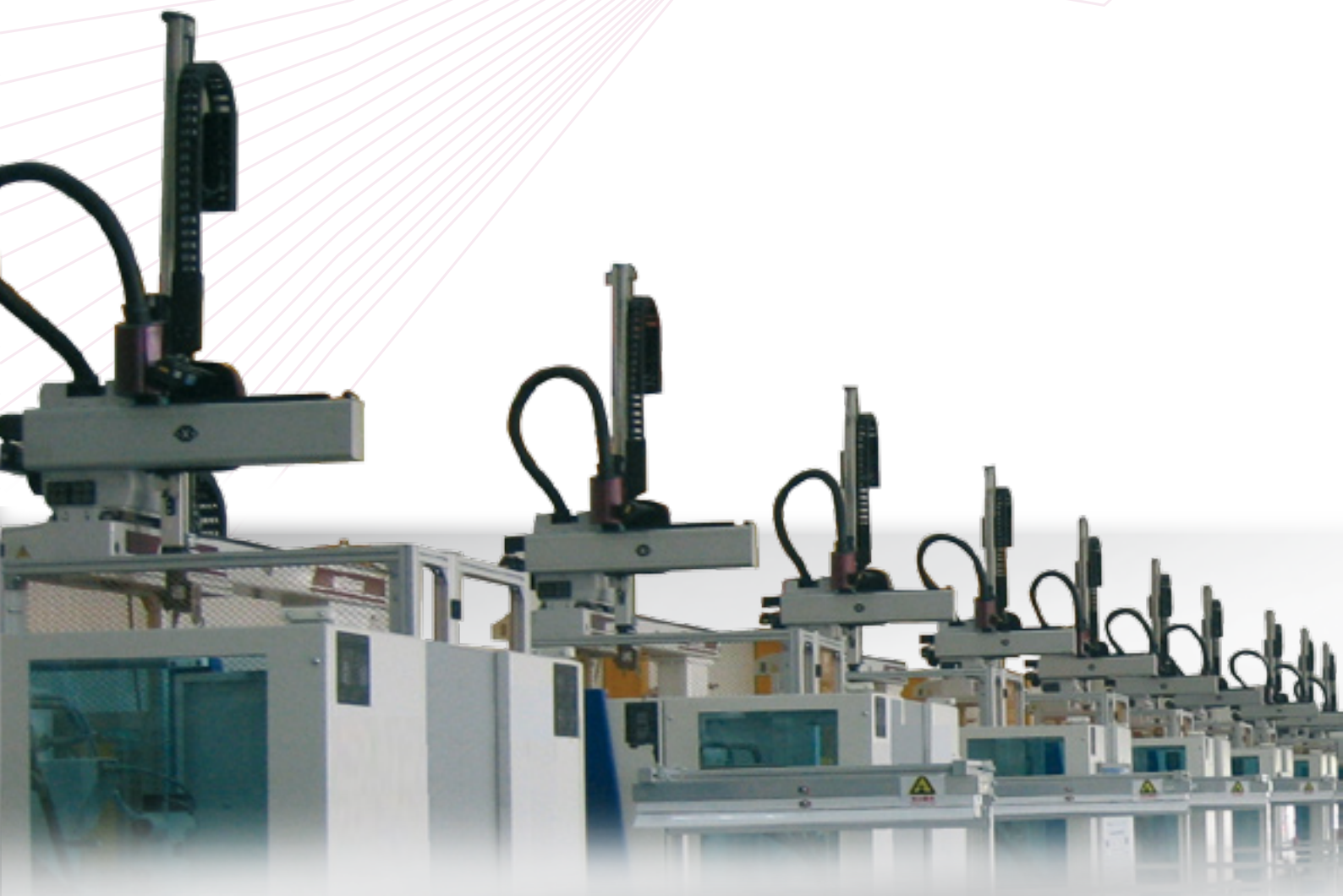

*WITTMANN Named a "Best Buy" for Robots*

Technology working for you.

***Wittmann***

Progress through Innovation

# The Innovative Robot Concept

Decades of application experience and innovative developments have made the WITTMANN robots what they are today – the best robots for the plastics industry! Well planned detailed solutions and state-of-the-art components allow highest reliability, shortest cycles and long intervals between maintenance.

## Smart-Bus Technology

All sensors and actuators on the robot are directly wired to the intelligent control card under the robot hood. The connection to the control cabinet and the Teach Pendant is a simple Bus-cable.

- Total flexibility in the production of injection molded parts
- Single point programming through robot TeachBox
- Safe investment with ability to exchange peripheral system at any time.

## Kick Stroke Beam

A large aluminum extrusion provides a stiff, vibration free foundation for the vertical arm. The reduced moveable mass allows high acceleration and deceleration for extremely short cycle times. The bearings for horizontal stroke and kick stroke are positioned in the main carriage next to each other to provide optimum stiffness and minimum vibration for high speed operation, allowing precise insertion and removal.

## Powerful Servo Drive

Servo drives are used on all 3 main axes.

## Z-axis (horizontal stroke)

All larger robots including the W721/W821 model are driven in the Z-axis via rack and pinion with built in lubrication chamber for high speeds and long life operation. The rack and pinion drive guarantees precise positioning also with long strokes, avoiding the flexibility of long belts.

## Rugged Steel Beam

Precision machined for perfect alignment of rails and rack.

## Reduced Maintenance

As a standard the robots are equipped with linear bearings with lubrication chains. These are the latest technology bearings providing lubrication intervals up to one year! (Depending upon robot cycle and operating conditions).

## Additional Rotational Axes (optional)

- A-axis wrists pneumatic 0-90° and/or 180°.
- B-axis motor driven 0-270° rotation for removal from fixed or alternatively movable platen side and for flexible placing of parts in different orientation. Programming through teach pendant.
- Servo A/B/C-Axes for up to six degrees of freedom.

## C-axis (standard)

C-axis rotation for placing parts. Compact design for minimum mold opening. Pneumatically operated rack and pinion drive for high and constant torque during rotation.

## Integrated Control Cabinet

Use of state-of-the-art compact servo modules integrated on the robot itself eliminates the need for an external control cabinet. The integrated control cabinet is mounted behind the horizontal axis for valuable space savings in the molding shop.

- Space saving
- Short motor and encoder cables
- Less cables and connections to fail
- Highest reliability of robot operation

The integrated control cabinet allows electrical connection of external I/O-modules via a bus cable for the direct control of all attached peripheral equipment.

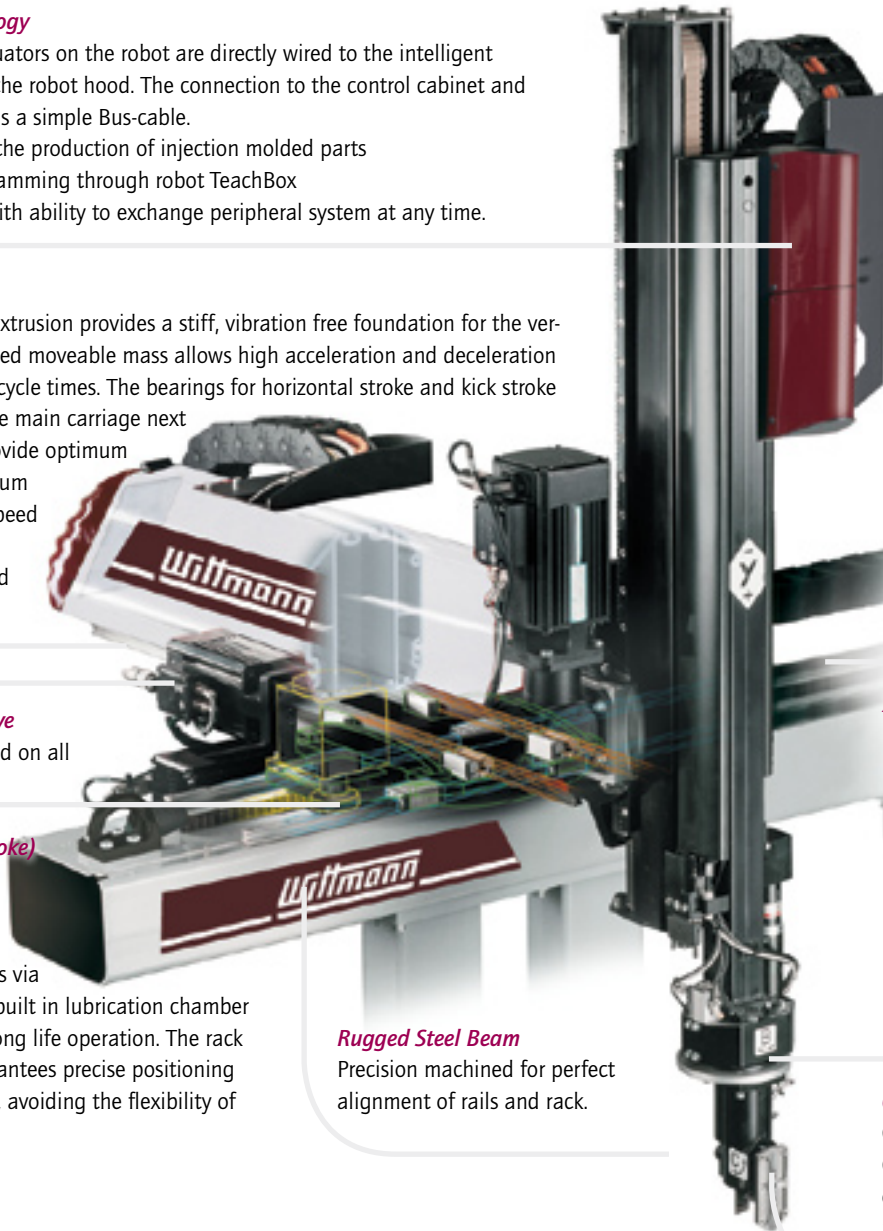

## R7.2 and R8 Robot Control

The entire WITTMANN robot series can be equipped with either the R7.2 control or, effective immediately, the new generation R8 control. Robots equipped with the R7.2 control are designated W7 followed by the appropriate model number whereas the robots with the R8 control have the designation W8 and corresponding model number.

Both types of control offer the user a comfortable graphical user interface via the Touch Screen TeachBox for direct selection of all functions. To avoid unintended operation, the TeachBox can be unplugged from the sub-pendant which contains the main operating functions of the robot. Teach programs can either be saved via the integrated USB-port – on the memory stick provided – or on an integrated flash card memory.

### Advantages

- Shortest training time for personnel.
- Free programming of every robot operation.
- Infinite diagnostic possibilities of the robot functions.
- Integrated observation of maintenance intervals.
- Different programming levels for the respective user profile.



### Total Flexibility

The control system offers 3 levels of operator interface as standard. The Graphical Editor for easy creation of standard routines, the Tooling Editor for the modification of a few select commands and, the Text Editor for ultimate programming freedom.

This allows any arbitrary robot sequence to be programmed via simple, intuitive menu navigation. Neither editor needs command codes, the designated functions are executed directly at the robot and are transferred via one keystroke into the program. The naming of the peripheral inputs and outputs, cylinders, grippers, and vacuum cycles facilitates the readability and allows for a clearly arranged program structure.

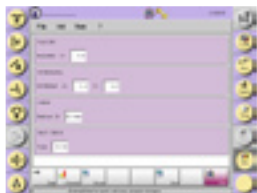

Tooling Editor –  
Filtered steps for  
minimum adjustment



Graphical Editor –  
8 steps to success

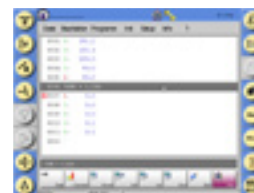

Text Editor –  
Ultimate flexibility  
in programming

### Additional Features of the R8 Control

- Ethernet interface for the connection to a company wide intranet or internet.
- Eco-Mode: automatic optimization of axes velocities outside of the mold for smooth operation of the robot.
- Smart-Removal: shortest part removal time through acceleration of the vertical arm during mold open motion.
- Freely programmable safety areas: the user can define the areas of robot motion to avoid collisions with components of the IMM during manual mode.
- Analog vacuum switches: allows programming of limit values for the vacuum in order to provide part recognition in the end-of-arm-tooling.



Safety Area



Analog Vacuum Circles

# The Innovative Series of Small Robots

The robot models **W701**, **W711**, **W713** as well as the **W801**, **W811** and **W813** are perfectly suited for smaller molding machines up to 200 tons clamping force.

This line of robots has a common fixed kick stroke design. The rugged, specially reinforced aluminum profile is attached directly to the main carriage so that nothing is sticking out towards the injection unit. Even on small molding machines there is no possibility of collision with the hopper.

The rugged lightweight vertical arm is guided by high capacity linear bearings to allow fast movement with minimum vibration, for precise insert and part removal applications.



W711

## W701 / W801 3-Axis High-Speed Series

*The smallest model in the 3-axis servo robot line designed for mounting on molding machines up to 120 tons clamping force.*

- Motorized servo drives on all 3 main axes.
- Compact construction of the vertical axis and the highly integrated wrist rotation allow handling of parts with the minimum amount of mold open space.
- High performance servo drives and high grade linear rails on all axes permit high velocities and the shortest part removal times.
- Many additional features of the entire robot series are available as options including: vacuum and gripper circuits and different I/O modules for the control of complex peripheral equipment.



W701

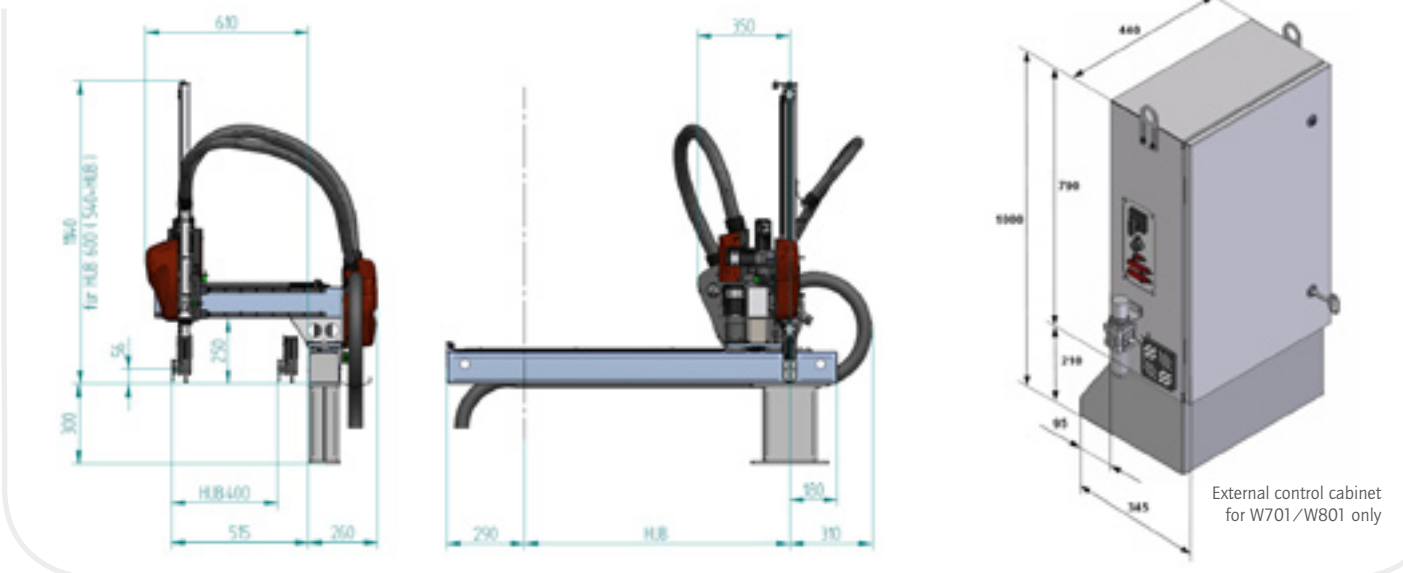

## W711/W811 Universal Series

### The Optimum Robot Providing Flexible Automation for Your Current and Future Requirements on Smaller Molding Machines

- High performance robots featuring servo motor drives for all three main axes.
- Optional rotational axes allow additional flexibility.
- Extremely smooth operation with lowest noise.
- Minimum part removal times are essential for the highest productivity of the automation cell e.g. production of thin wall components. The vertical arms of the W711/W811 and W713/W813 model robots are stiff but lightweight rib-reinforced aluminum profiles, driven via belt by a servo motor, thus reducing the moving mass.



W711

## W713/W813 with Telescopic Vertical Axis

Incorporating the same basic design as the W711/W811 with 3 servo driven main axes.

- Vertical axis with telescopic stroke for low overall height.
- Perfect for smaller molding machines in production halls with low ceiling heights.
- Extremely quiet operation for lowest noise.
- Very compact telescopic arm design for small mold opening height and fast removal times.



W713

## Model S: Double-Arm Series

The W711/W811 and W713/W813 model robots are available with a double-arm option having an additional servo driven vertical arm and gripper finger for the removal of sprues from 3-plate molds.



W713S

### Small Series

Robot	W701/W801	W711/W811	W711S/W811S	W713/W813	W713S/W813S
Horizontal stroke Z-axis max. mm	1.500	2.500	2.500	2.500	2.500
Vertical stroke Y-axis max. mm	1.000 Single vertical axis	1.200 Single vertical	1.200 Single vertical axis	1.000 Telescopic axis	1.000 Telescopic axis
Kick stroke X-axis max. mm	400	620	420	590	390
Kick stroke reach max. mm	515	800	800	790	790
Control Cabinet B x H (+Base) x T	440 x 790 (+210) x 250	integrated	integrated	integrated	integrated
Handling load parts-gripper max. kg	3	5	5	5	5
Injection molding machine clamping force t	25-120	50-200	50-200	50-150	50-150

# The Advanced Robot Series

All larger robots – starting from the W721/W821 models – are designed with a moveable kick-stroke beam which is guided directly in the main carriage. The reduced moving mass allows high acceleration and deceleration for extremely short cycle times.

## W721 / W821 – W723 / W823 The Compact Series

- W721 / W821**  
 The vertical arm consists of a rigid aluminum extrusion and guided by heavy-duty linear bearings and driven by a servomotor via belt to allow high speeds and short removal times.
- W723 / W823**  
 Telescopic Vertical Axis: The gripper is mounted in front of the telescopic arm allowing for a very short length, for minimum overall height and fast movements.



## W731 / W831 – W732 / W832 The Middle Series

The larger rugged steel main beam on models W732/W831 and W732 /W832 allows for a wider distance between the main bearings and therefore longer kick-strokes up to 900 mm (35.4") with a 1,190 mm (46.9") reach and longer vertical strokes up to 1,600 mm (63").

- W731 / W831**  
 The W731/W831 use the same vertical arm design as is used for the W721/W821 but with vertical strokes up to 1,400 mm (55"). Due to the high operating speeds of the vertical arm and payloads up to 10 kg (22lbs), the W731/W831 is one of our bestsellers for machines up to 500 tons.
- W732 / W832**  
 The vertical arm is a rigid aluminum extrusion with two high load linear bearings and a maximum length of 1,600 mm (63"). Designed for payloads up to 20 kg (44 lbs) and offering a high torque C-axis rotation for placing, the W732/W832 is a popular robot for insert jobs.



Compact/Middle Series				
Robot	W721 / W821	W723 / W823	W731 / W831	W732 / W832
Horizontal stroke	4.000	4.000	5.000	5.000
Z-axis max. mm				
Vertical stroke	1.200	1.200	1.400	1.600
Y-axis max. mm	Single vertical axis	Telescopic axis	Single vertical axis	Single vertical axis
Kick stroke				
X-axis max. mm	550	550	800	900
Kick stroke reach max. mm	775	820	1.025	1.190
Max. handling load parts-gripper max. kg	10	10	10	20
Injection molding machine clamping force t	40-400	40-400	100-500	200-650

## W733/W833 – W743/W843 *The Middle Series with Telescopic Arm*

All larger robots beginning with the W733/W833 models are equipped as standard with our patented telescopic vertical arm. The main vertical arm is driven via rack and pinion. The front arm is driven at double the speed via a belt.

- Minimum overall height of the robot.
- Double speed of the end-of-arm-tooling and short in/out times.
- Long vertical strokes for palletizing.
- **W733/W833**  
Gripper and part weight up to 15 kg (33 lbs) with a maximum vertical stroke of 1,800 mm (71"). Therefore best suited for flexible automation on injection molding machines up to approximately 750 tons.
- **W743/W843**  
The larger more substantial main beam and double walled kick stroke extrusion allow handling payloads up to 35 kg (77 lbs) and vertical strokes up to 2,600 mm (102") for palletizing on pallets located on the shop floor.



W733

## W753/W853 – W773/W873 *The Large Series*

Intended for large molding machines and payloads of 50 kg (110 lbs) to 125 kg (275 lbs). The kick-stroke beam as well as the vertical telescopic arm, are constructed of thin walled steel tubes to allow fast movement with minimum vibration.

- **Options:**
  - Servo driven rotational axes for secondary requirements.
  - A variety of additional gripper and vacuum circuits for complex automation.

ADDITIONAL INFORMATION ABOUT OUR COMPREHENSIVE OPTIONAL FEATURES AVAILABLE ON REQUEST.



W753

Middle/Large Series				
Robot	W733/W833	W743/W843	W753/W853	W773/W873
Horizontal stroke	5.000	6.000	6.000	10.000
Z-axis max. mm				
Vertical stroke	1.800	2.600	3.000	3.000/3.600
Y-axis max. mm	Telescopic axis	Telescopic axis	Telescopic axis	Telescopic axis
Kick stroke				
X-axis max. mm	900	1.200	1.500/2.000	2.000
Kick stroke reach max. mm	1.290	1.625	2.040	2.800
Handling load parts-gripper max. kg	15	35	75	125/60
Injection molding machine clamping force t	200-650	500-1.200	700-2.000	1.000-4.000

# Robots for Fastest Removal Times

The ultra high speed robot series has been developed to achieve the fastest part removal times and allows mold open times of less than 1 second. In order to constantly achieve these short removal times over the long term, the vertical axis is activated directly over a planetary gear box engaging with a generously dimensioned tooth belt. This guarantees direct transfer of forces as well as minimizing the moving masses.

For mechanical absorption of the high acceleration and deceleration forces of up to  $65\text{m/s}^2$ , the vertical axis is designed with an extremely torsion stable kick stroke which is internally reinforced with ribs. The vertical axis consists of an aluminum profile which by means of finite element analysis, is designed for the lightest weight and highest stiffness.

— **Advantages:**

- Highest productivity of the injection molding machine with the shortest cycle.
- Minimizes all moving masses for the highest acceleration and deceleration.

Fastest Removal			
Robot	W721UHS	W732UHS	W733UHS
Horizontal stroke Z-axis max. mm	4.000	5.000	5.000
Vertical stroke Y-axis max. mm	1.200 Single vertical axis	1.600 Single vertical axis	1.400 Telescopic axis
Kick stroke X-axis max. mm	500	900	900
Kick stroke reach max. mm	790	1.190	1.290
Handling load parts-gripper max. kg	3	7	5
Injection molding machine clamping force t	40-400	200-650	200-650



## Rotational Servo Axes A/B/C

For applications with additional degrees of freedom, WITTMANN supplies optional servo rotational axes around all 3 principle axes. Programming with increments of  $0.1^\circ$  (R7.2) and  $0.01^\circ$  (R8) ensures extremely fine adjustment.

— **Servo A-axis**

Allows the wrist flip to independently position the end-of-arm tooling and molded parts, i.e. in the mold area as well as during placement.

— **Servo B-axis**

Allows rotation of the end-of-arm tooling in the mold area between the fixed and flexible adapter plate and the arbitrary orientation of parts with a flip-down gripper during placement.

— **Servo C-axis**

Allows removal of molded parts from the moving as well as the fixed mold halves and the arbitrary presentation to downstream equipment.

— **Advantages:**

- Compact mechanical design minimizes mold open.
- Highly dynamic servo motors and precise planetary gearboxes enable extremely fast movements.





# Robots for Fastest Horizontal Removal

**WITTMANN offers a range of horizontal robots for the removal of thin wall parts with cycle times of less than 6 seconds.**

— **W7XH**

The horizontal side entry axis is driven by a **SCARA** type rotational movement. The gripper platen is synchronized for extremely fast, servo driven linear in/out movement of the gripper. This system provides very stable high speed operation with low vibration and requires minimum floor space next to the molding machine. The vertical axis and kick stroke are also servo-driven.

— **W723H**

Telescopic horizontal axis and kick stroke are servo driven. The C-axis for placing parts is mounted directly to the telescopic carriage, requiring minimum floor space next to the molding machine. The vertical position is adjustable mechanically or pneumatically driven e.g. for placing in a tray.

— **W727H**

Special servo driven, side entry axis for the automation of packaging parts and **IML** applications (containers, lids, etc.). The robot is mounted on a rugged frame with additional, servo driven stacking axis for parts placement. For stack mold applications, two independent side entry axes are available with respective stacking axes (for further information see IML literature).

— **W737H**

The larger **W737H** model has been developed for fastest horizontal axis motion on molding machines up to 700 tons clamping force. With otherwise identical equipment to the smaller **W727H** model, this side entry robot can handle a payload of up to 30 kg for each horizontal axis.



W7XH



W727H

Horizontal Removal				
Robot	W7XH-900	W7XH-1200	W727H	W737H
Horizontal stroke Z-axis max. mm	900	1.200	2.000	3.000
Vertical stroke Y-axis max. mm	300	600	-	-
Kick stroke X-axis max. mm	300	500	-	-
Kick stroke reach max. mm	550	750	-	-
Handling load parts-gripper max. kg	1,5	1,5	15	30
Injection molding machine clamping force t	50-150	80-200	100-350	250-700

# Top Entry Robots for Stack Molds

Robots with two servo driven vertical arms for the automation of stack molds on injection molding machines up to approximately 500 tons clamping force. All robot models feature a fixed kick stroke beam. Both vertical arms are either single or telescopic with a payload up to 20 kg (44 lbs) each.

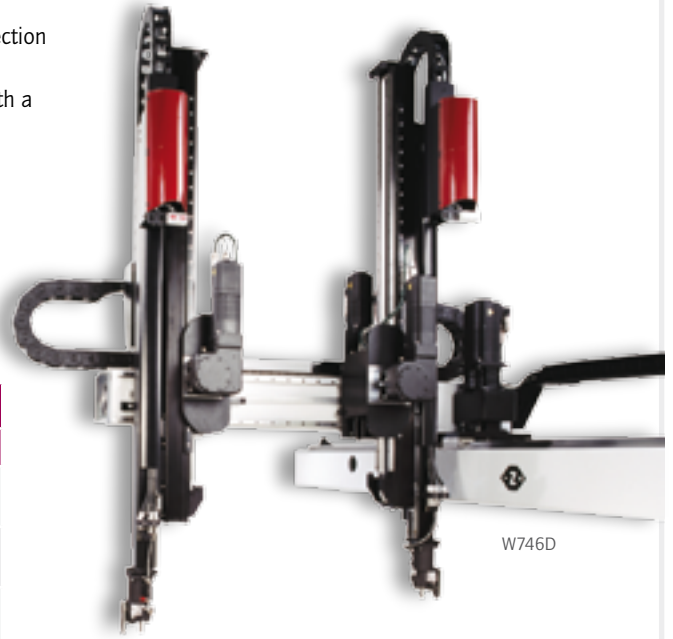

Stack Mold			
Robot	W711D	W744D	W746D
Horizontal stroke Z-axis max. mm	2.500	6.000	6.000
Vertical stroke Y-axis max. mm	1.000 Single vertical axis	1.600 Single vertical axis	2.000 Telescopic axis
Kick stroke X-axis max. mm	400 - 2x200	600 - 2x300	600 - 2x300
Kick stroke reach max. mm	800	1.200	1.200
Control Cabinet B x H (+ Base) x T	integrated	integrated	integrated
Handling load parts-gripper max. kg	3	20	20
Injection molding machine clamping force t	50-200	300-800	300-1.000

## Special Applications

WITTMANN supplies the optimum robot for your specific application. These robots stand out through their complete flexibility in configuration and suitability for special applications.

### Examples:

- Two robots can be mounted on one horizontal axis to share the work space in a time critical application or to use a common palletizing area.
- Extra long horizontal axes for work areas on both sides of the injection molding machine.
- Robots can be delivered with an external control cabinet to connect extensive amounts of peripheral inputs and outputs.

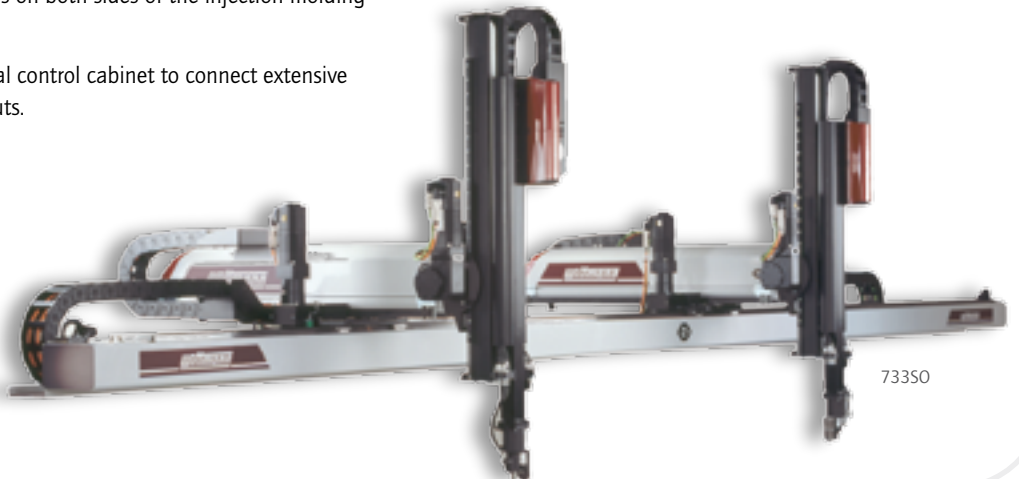

# RFID – Tooling Recognition

Technology based on “Radio Frequency Identification” (RFID) is used on WITTMANN robots to identify end-of-arm tooling and select the correct teach program for fail-proof operation. Another innovation by WITTMANN!

An RFID reader is mounted inside the plate of the wrist axis and detects without any contact a unique 64-bit identification number in a transponder fixed to the respective end-of-arm tooling. Based on the unique ID the control system automatically selects the right teach program.

## Advantages:

- Eliminates errors by operators.
- Avoids damage to molds and downstream equipment.

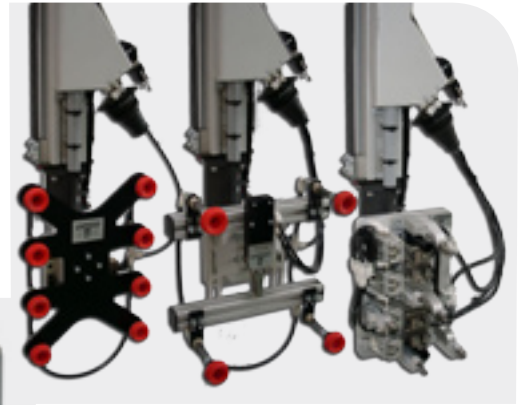

# Control of Downstream Equipment

The universal WITTMANN R7.2 and R8 robot control systems provide multiple enhancements and interfaces for the integration of peripheral and downstream equipment. This increases the performance of the overall system and allows central access to all functions via the robot TeachBox.

## Examples of interfaces

- Up to 6 independent signals for programmable conveyor indexing.
- Control of up to 16 vacuum and simultaneously 16 gripper circuits for the realisation of complicated end-of-arm tooling functions.
- Extensions of the control with decentralized I-/O modules on the robot and in the control cabinet.
- Connection of external decentralized I-/O modules via CAN-Bus.
- Mirroring of the TeachBox across Intranet/Internet via VNC.
- Email function on R8 control.





Technology working for you.

**Wittmann Kunststoffgeräte GmbH**

Lichtblaustraße 10

1220 Vienna | Austria

Tel.: +43 1 250 39 0 | Fax: +43 1 259 71 70

[info@wittmann-robot.at](mailto:info@wittmann-robot.at)

[www.wittmann-robot.com](http://www.wittmann-robot.com)