

The complete range

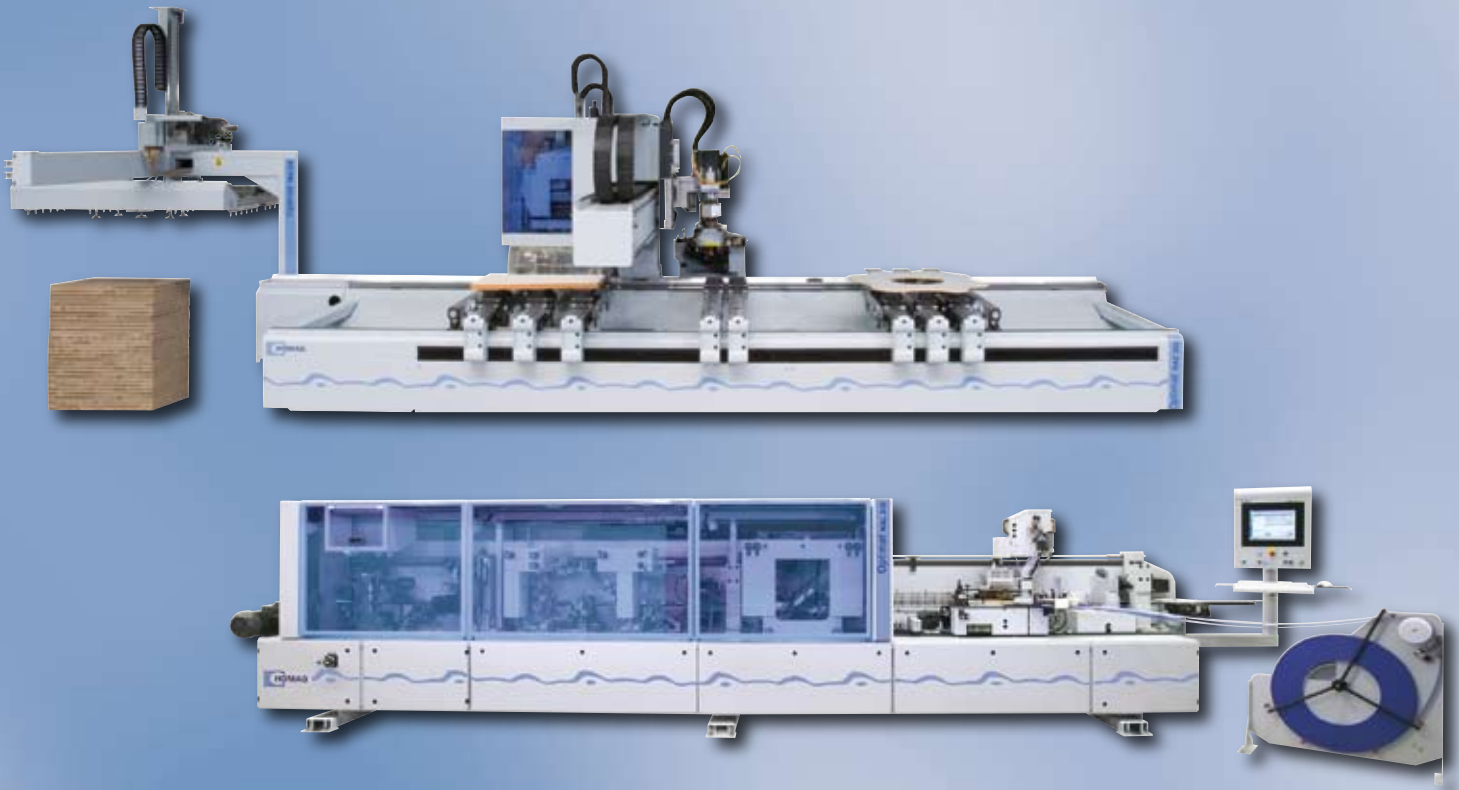

The HOMAG Group: Your partner for successful production

The HOMAG Group is the world's biggest association of specialists in the field of precise, economical woodworking. The ideal partner for top-class machines, plants and systems covering every conceivable processing operation. Make success your goal – with the HOMAG Group.



A seamless product range

HOMAG is an international market leader and sought-after specialist in the fields of sizing and edge banding - with a unique product range:

- Combined sizing and edge banding machines
- Single and double-sided edge banding machines
- Double-end tenoners
- Single-sided sizing and profiling machines

- Postforming machines
- Transport elements
- Complete machine lines
- Highly flexible CNC processing centres and routers
- Production cells and automation technology
- Powerful, user-friendly control systems
- Systems for Lightweight Technology

Success with a system

The HOMAG Group understands what the woodworking industry needs, offering a range of pioneering production solutions designed to ensure success in every sector. This is achieved by concentrating our experience and know-how in a high-powered company group and by making consistent use of synergy effects. Our plants and machines are designed using a cohesive concept to ideally complement each other. Opt for quality from a reliable one-stop supplier – from HOMAG.

Low-cost solutions for industry and woodworking shops

Whether for industrial producers or woodworking shops – the HOMAG Group offers a complete range designed for highly economical wood-working. There are three performance classes to choose from:

- **Optimat** – versatile standard range complying to the highest standard of HOMAG quality at an affordable price

- **profi** line – innovative machine range to address sophisticated requirements in terms of precision and economy
- **power** line – high-tech flagship range with outstanding performance right from batch size 1!

The modular design concept permits customer-specific solutions for both individual machines and complete production lines.



HOMAG Group parent facility in Schopfloch, Baden-Württemberg

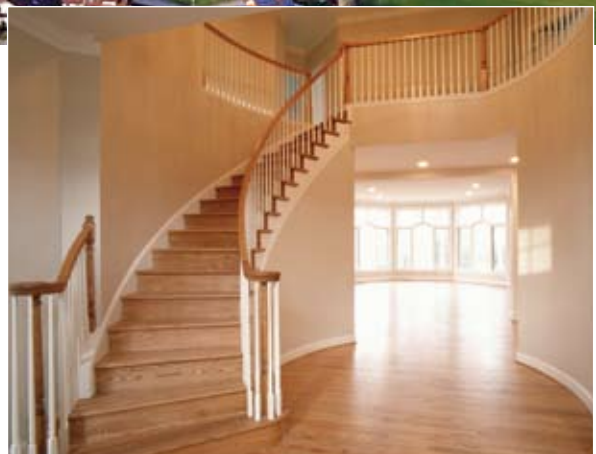

KAL series: The optimum solution for straight and softformed edges

The highly flexible, efficient series for edge banding. Ideal for any type of edging material: Solid wood, melamine, PVC, ABS and veneer edges, off the coil or in fixed lengths, for banding with hot melt or PU adhesive.

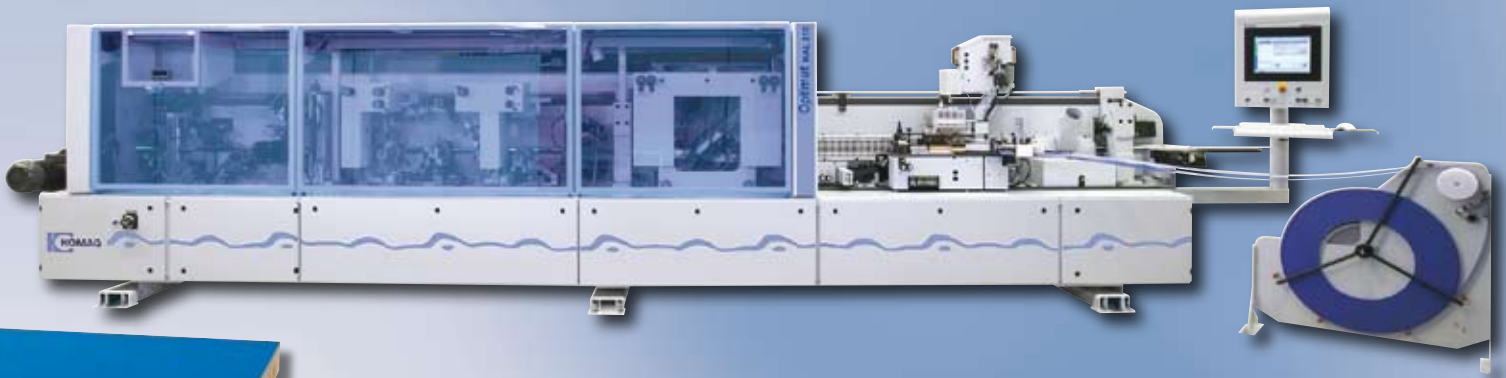

Optimat KAL 210



The most important benefits:

- Industrial design
- Simple machine maintenance
- Environmentally friendly technology
- Simple operation
- Modern, functional design

Two single-sided machine models to choose from

The two models are ideally configured for processing straight or softformed edges:

- Gluing unit
- Edging magazine
- Pressure zone
- Finish processing units
- Upstream jointing section

We also build double-sided KAL machines.



Optimat KAL 310/E



Individual processing to the highest standard of quality

Perfect finish processing determines the quality of the workpiece. This is why we offer a wide range of units and options from trimming through to finish processing.

FPR and FPL series: Fast and flexible for precise processing

Our double-end tenoners are the number one choice when it comes to efficient, versatile processing of coated solid workpieces and chipboard, MDF or other panels.



Optimat FPR 225 double-end tenoner



Optimat

Double-end tenoners from the Optimat series are reliable, compact „work horses“ designed to cope with wide-ranging applications: Angular or inclined cuts, sizing, profiling, rebating, grooving and corner processing. Featuring durable technology, extreme performance and optimum availability, these models are just the right option for coping with tough, everyday operating conditions.

Solid from the base up, with enormous versatility

HOMAG double-end tenoners are durable, compact and highly reliable, as well as guaranteeing safe, precise work-piece guidance. The steplessly adjustable feed adapts ideally to any tooling or material requirements.

Convenient control system – simple operation

Using the display and with the benefit of user prompting, you can talk to your machine in „plain text“ right from day one: The reliable fast-track route to meet your productivity target.

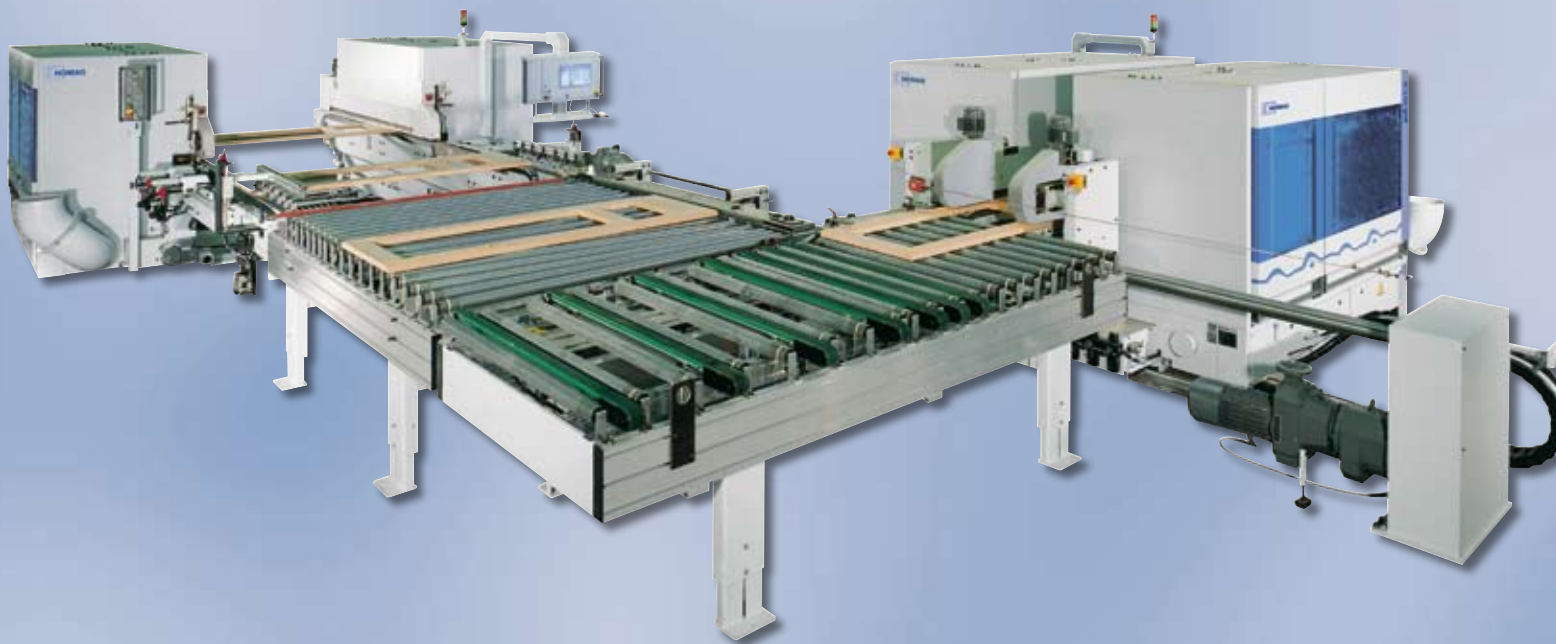

profi line FL 20 double-end tenoner

profi line

This is a series which simply does it all: e. g. angular cuts, profiling, grooving or sanding. When integrated with material handling systems, single-sided machines provide precision processing. And it takes non-standard assignments easily in its stride too:

- Contour trimming of curved workpieces in throughfeed
- CNC controlled trimming of rounded corners without templates
- High-precision trimming operations on flooring elements
- Processing of wide-ranging panel-shaped building materials
- Profiling frame components

KFL series: a new dimension in flexibility for sizing and edge banding

Whether for large or small production runs: Modern furniture production calls for powerful combined sizing and edge banding machines.

Ideally equipped for demanding requirements

Whether **Optimat** or **profi** line – our KFL series combination machines equipped with a heavy-duty continuous machine frame guarantee processing precision in continuous throughfeed. Space-saving solutions permit optional conversion or upgrading as required, through to the complete production line.



Optimat KFL 526

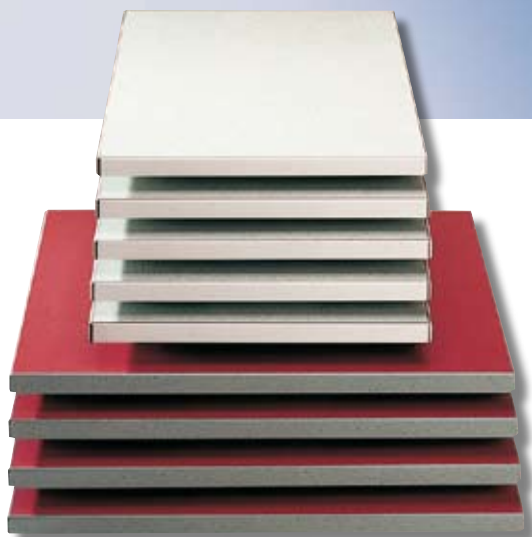

For a variety of needs and every conceivable edge

The wide range of supplemental units provides flexibility for a variety of operations such as panel sizing, profiling, rebating and grooving - as well as gluing all kinds of popularly used edging:

- Veneers
- Plastic edges in melamine or finish foils
- PVC edges up to 3 mm thick

The new dimension in industrial production

power line now permits more productive and successful manufacturing than ever before. With extreme high-volume output and high-speed just-in-time production of furniture, wall or ceiling panels and flooring elements. And all to a superb standard of quality.

Success with top performance

The new control engineering system used in **power** line takes care of fast system response and efficient management of all production processes. Every operation is precisely repeatable. All the operator needs to do is program the required processing result. We also offer efficient solutions for batch size 1 production.



profi line KFL 10 – KFL 20

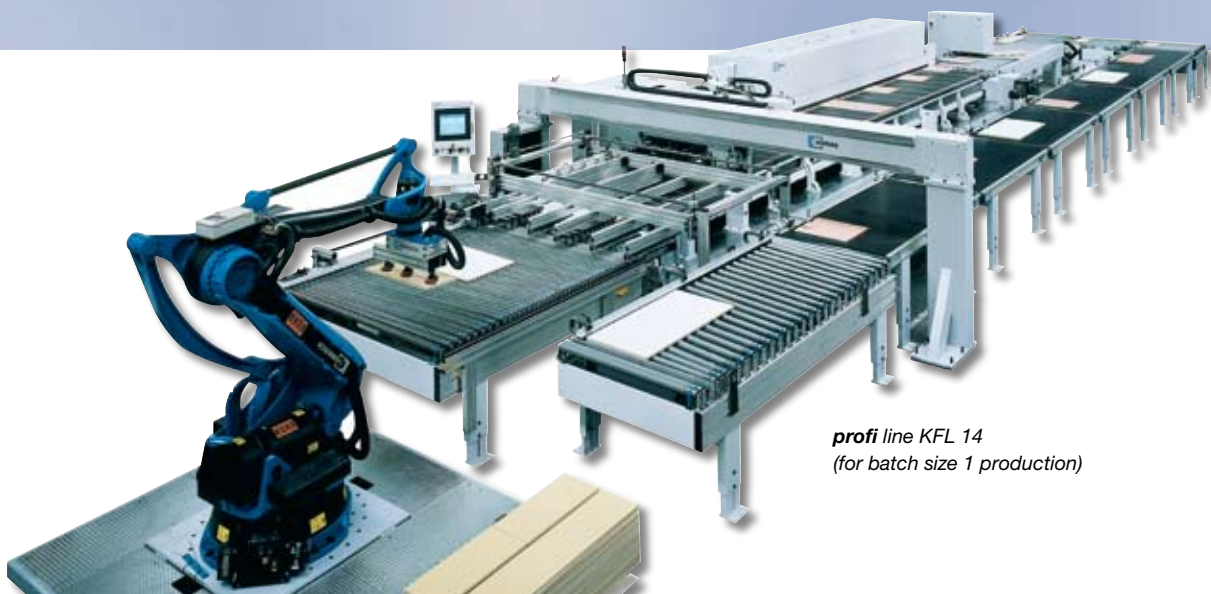
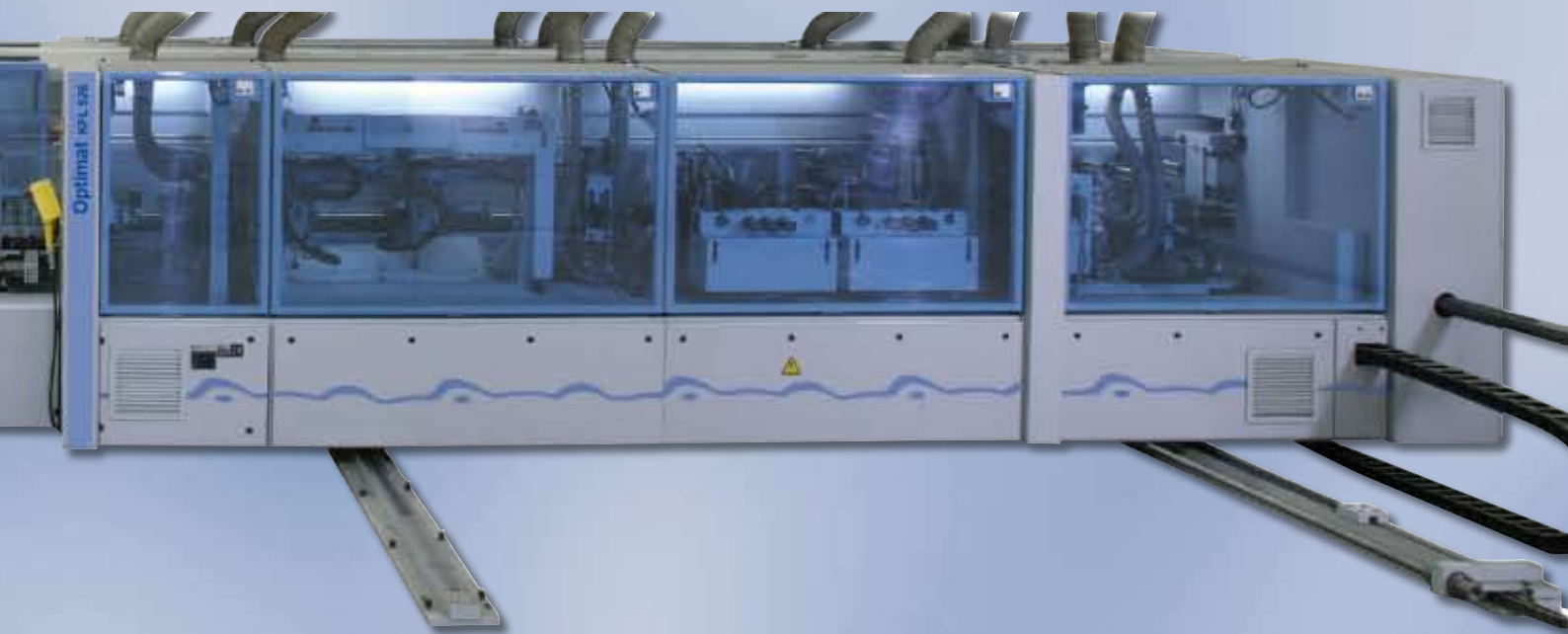

*profi line KFL 14
(for batch size 1 production)*

VFL postforming machines: Efficient – rounded corners in throughfeed

Postforming technology provides an impressive solution wherever particularly durable furniture with wear-resistant edges has to be produced, as this method permits continuously wrapped surfaces and edges – eliminating the need for a glue joint.



Postforming machine **Optimat VFL 310**



Individually tailored to your needs

Our postforming machines are available in a single-sided version or – for higher capacity requirements – in a double-sided machine version or alternatively as a high-performance plant. Feed rates range from around 10 m to over 30 m per minute – and you can choose freely from the range of available processing units.

Quality from the specialist

HOMAG has been an instrumental driving force in the development of the postforming technique. We have the competence, the experience and the know-how to develop high-performance, extremely reliable and durable solutions – such as the VF postforming machines or also machines for the postforming direct process which manufactures workpieces directly from coated panels.

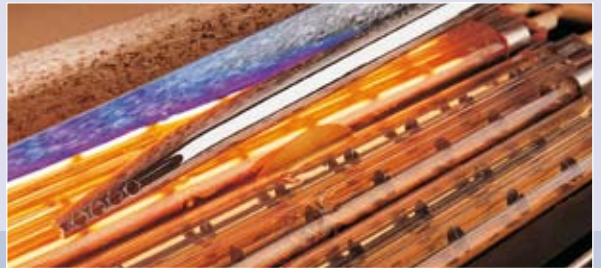

The T series for transport systems: Keeping production flowing

A perfectly coordinated material flow forms the basis for a smooth production process, with the transport elements which connect the different machines playing a central role.

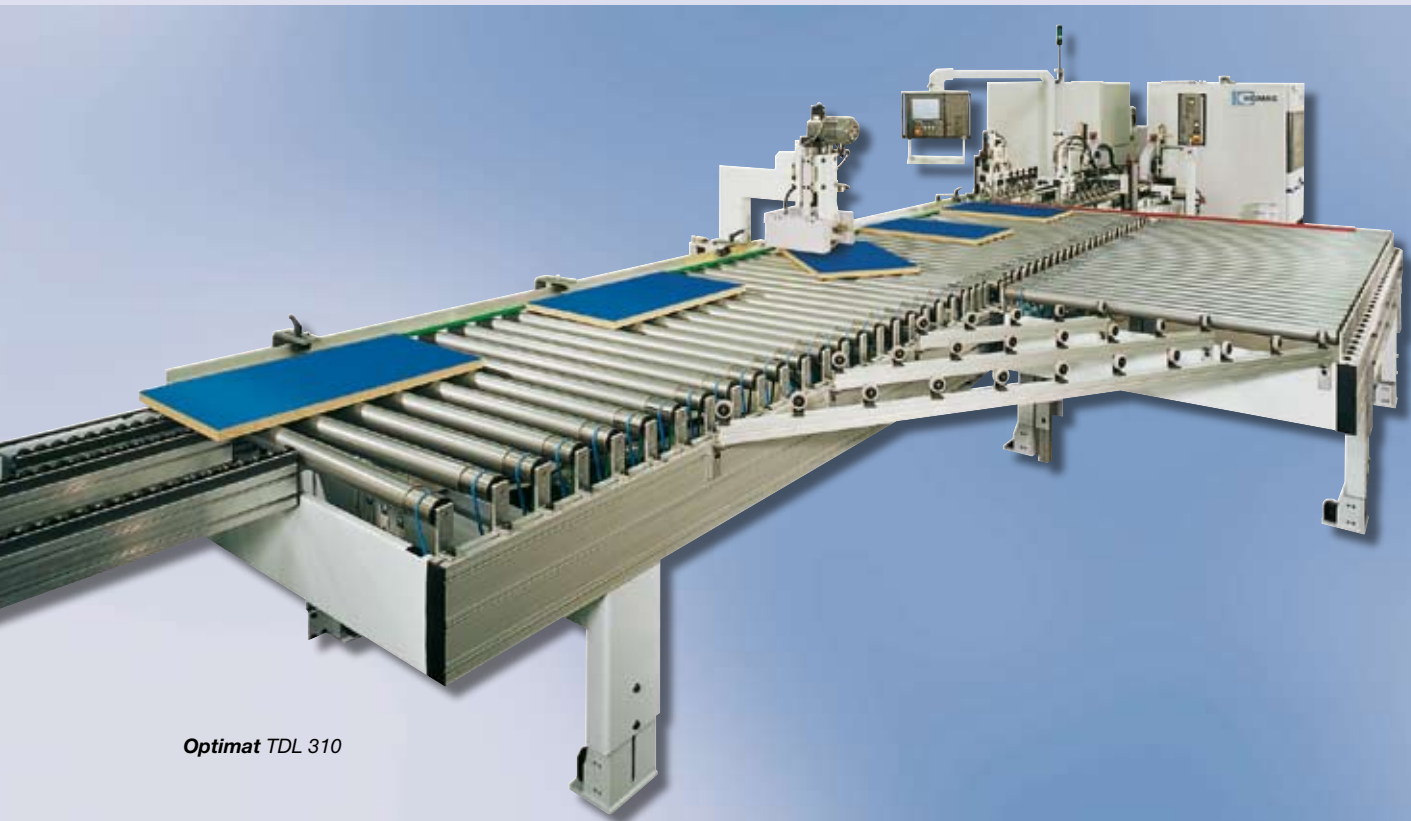

Optimat TDL 310

Elements of the T series:

- Roller conveyors
- Feeding tables
- Rotary stations
- Conveyor belts
- Angular transfers on one or two levels
- Intermediate transport systems



profi line TRL 100

Flexibility based on a range of modular elements

The various transport devices have to be precisely coordinated to your individual requirements. The HOMAG modular range of transport elements provides the ideal solution to any assignment. It contains everything you could conceivably need for efficient, individually tailored workpiece transport.

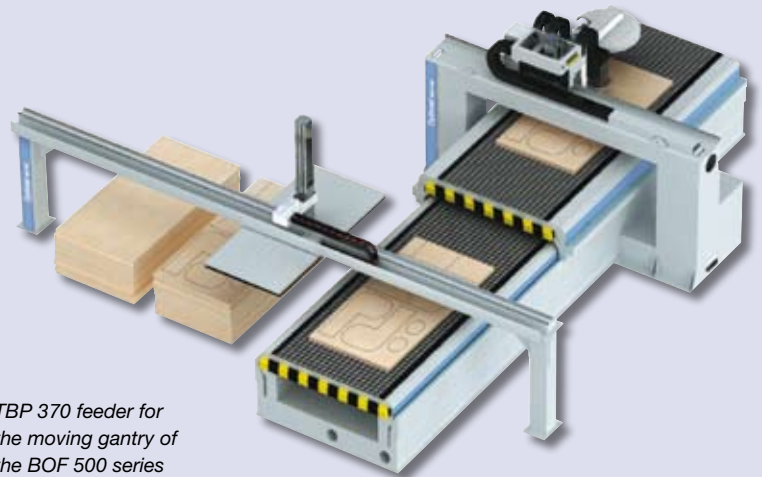

TBP 370 feeder for the moving gantry of the BOF 500 series

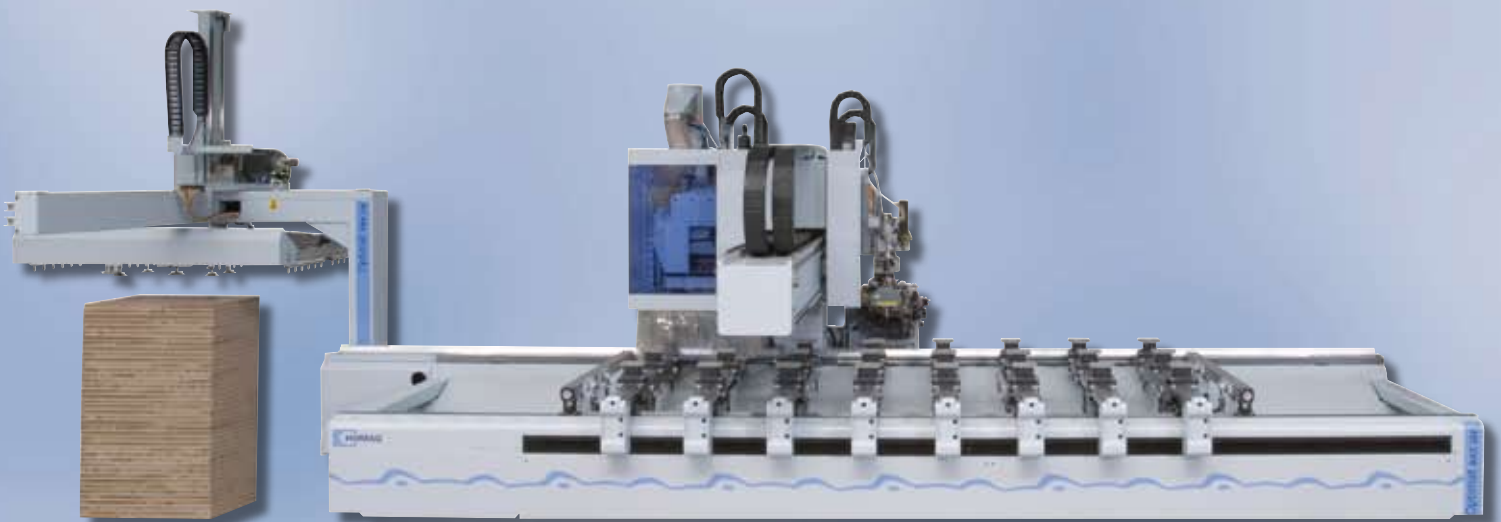

TBA 330 feeder for extension arm machines

The easy way to increased flexibility

HOMAG feeding systems turn processing centres into flexible production cells. System control via the processing centre ensures simple, efficient application – without the need for additional programming or networking input.

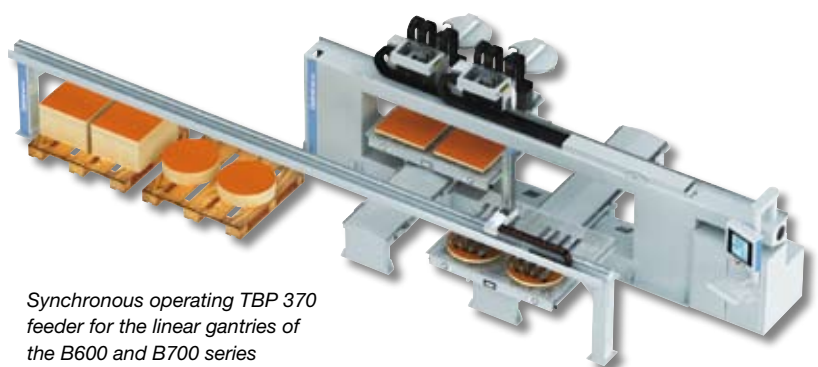

Synchronous operating TBP 370 feeder for the linear gantries of the B600 and B700 series

Processing centres: The way forward for modern production



Extreme efficiency:

Processing centres B200 and B300

CNC routers are making ever greater inroads into shaped component production applications. They ensure a high level of productivity and permit wide-ranging processing steps to be performed on a single workpiece: e. g. sizing, grooving, rebating, profiling, sanding, drilling etc.. The exchangeable edge banding unit turns the BOF into a BAZ, in other words a truly flexible workhorse.

Equipped to face any challenge

HOMAG offers a broad range of units to address every conceivable processing requirement. The units are fully automatically exchanged from the tool changeover system. And to ensure that you are ideally equipped to meet the challenges of the future, we are constantly developing new units.

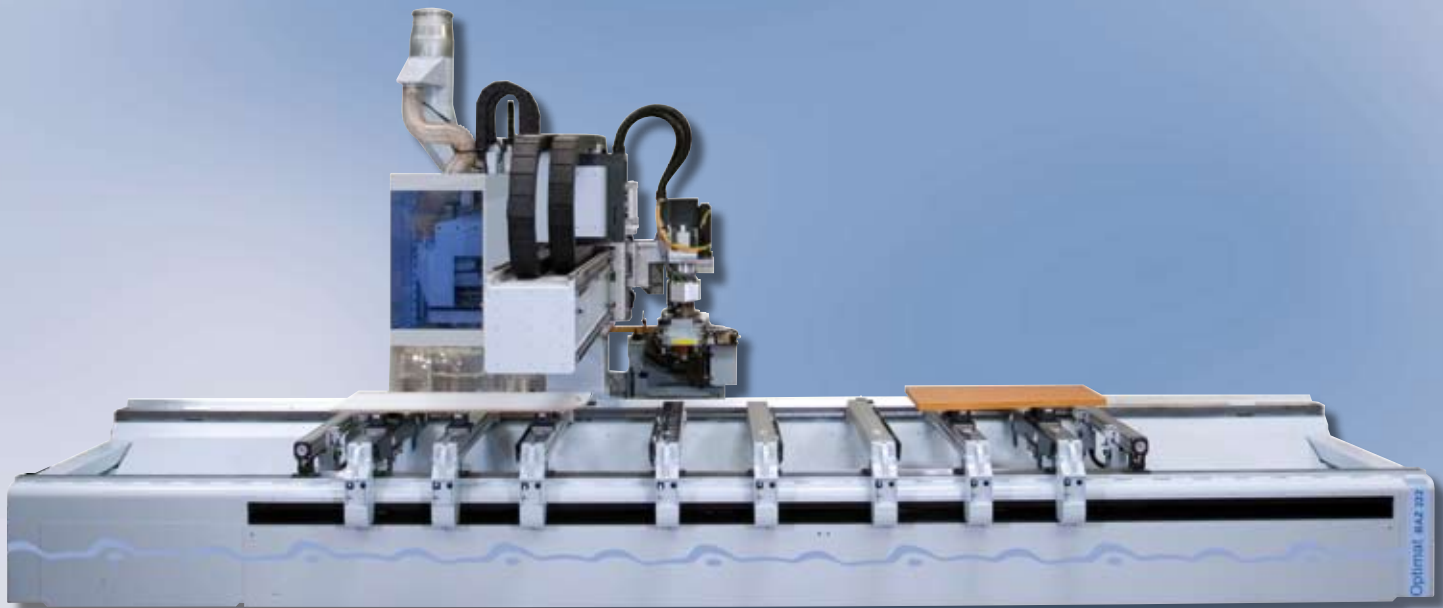

BAZ 222

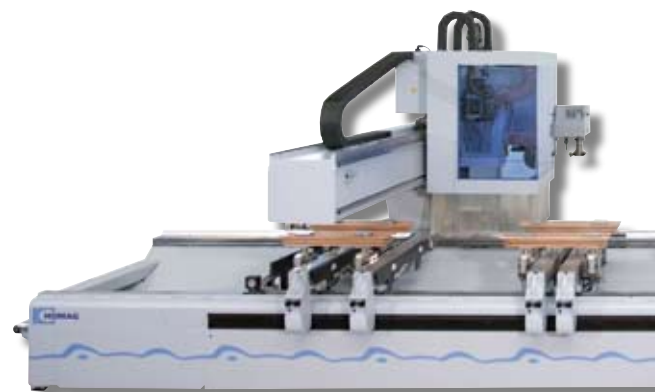

Venture 12XXL

The best solution whatever your needs

Processing centres from HOMAG are high-performance problem solvers when it comes to the production of furniture components, fronts, panels, windows, staircases, doors and countertops in every conceivable material – such as e. g. chipboard, solid wood, MDF or plastics.

Versatile all-rounders: The B200 and B300 series

These machines can be used to produce a diverse range of components – quickly, economically and to a high standard of quality.

- Extreme productivity and high performance due to unique double spindle technology
- Simultaneous deployment of two processing units for sizing and edge banding

- Replaces several individual machines, so saving space and eliminating the need for multiple part handling
- Improved part quality and less waste, due to the prevention of transport damage between work steps
- Flexibility and investment security due to individual equipment and a large selection of processing units

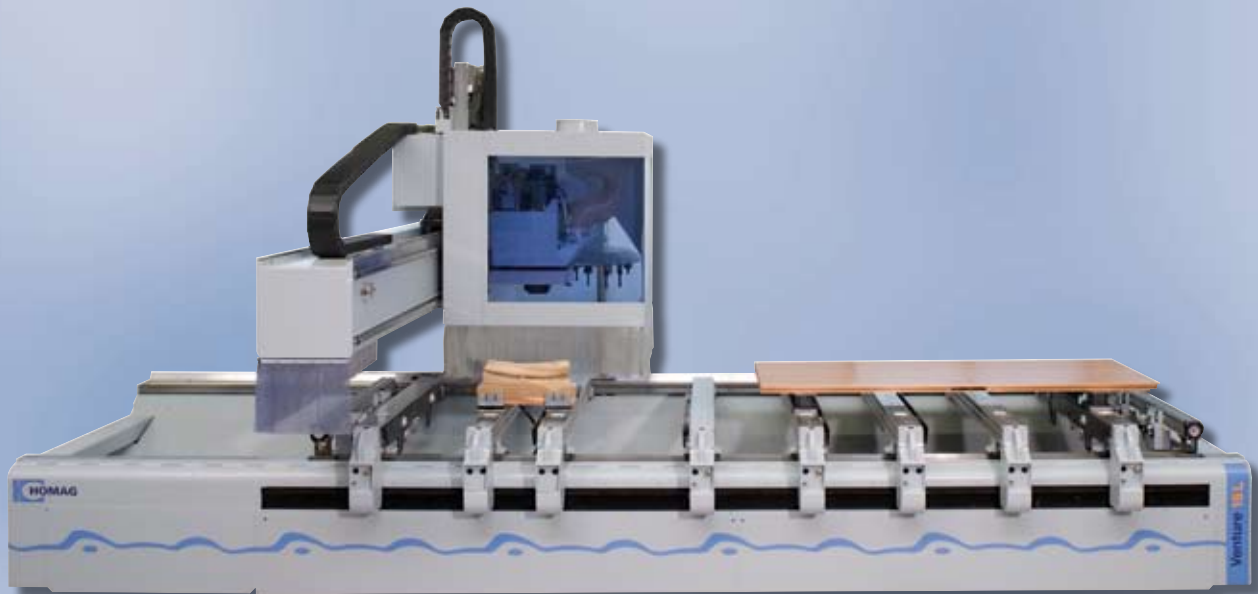

Venture 16L



Venture processing centres:

These processing centres from the B200/300 series are preconfigured for a variety of special applications such as:

- Venture 12 – the window specialist
- Venture 16 – The 5-axis solution for staircase manufacturers
- Venture 21 – the all-in-one solution for carpenters



Complete processing out of the top drawer: B600 and B700

Growing customer requirements, new products and short delivery times call for production technologies which are as flexible as they are efficient. It was to address these requirements that we developed the B600 and B700 series.



*Processing centre BOF 611
with optional full enclosure*

B600: Smart investment for maximum profit

Extreme flexibility coupled with high output – and at an unbeatably competitive price: These are the benefits offered by the B600 processing centre series. Economical processing solutions, e. g. for furniture production and shopfitting, interior fittings and the mobile home sector.

B600: Optimum performance, minimal space

With an impressively compact, optionally open or fully enclosed design, the B600 series takes up only a minimum of space. Despite its compact dimensions, it still permits the processing of large workpieces. These benefits, plus its extreme versatility, make this a highly popular option particularly in woodworking shops and small-scale industrial enterprises.

B700: the direct route to greater profit

For the very first time, the B700 series unites the outstanding flexibility and performance of a gantry machine with a minimal investment. Using modular unit technology, versatile scope for equipment, two independently operating processing tables and up to three processing units, this series sets whole new standards in terms of productivity, flexibility and quality – for example permitting the simultaneous processing of two different workpieces.

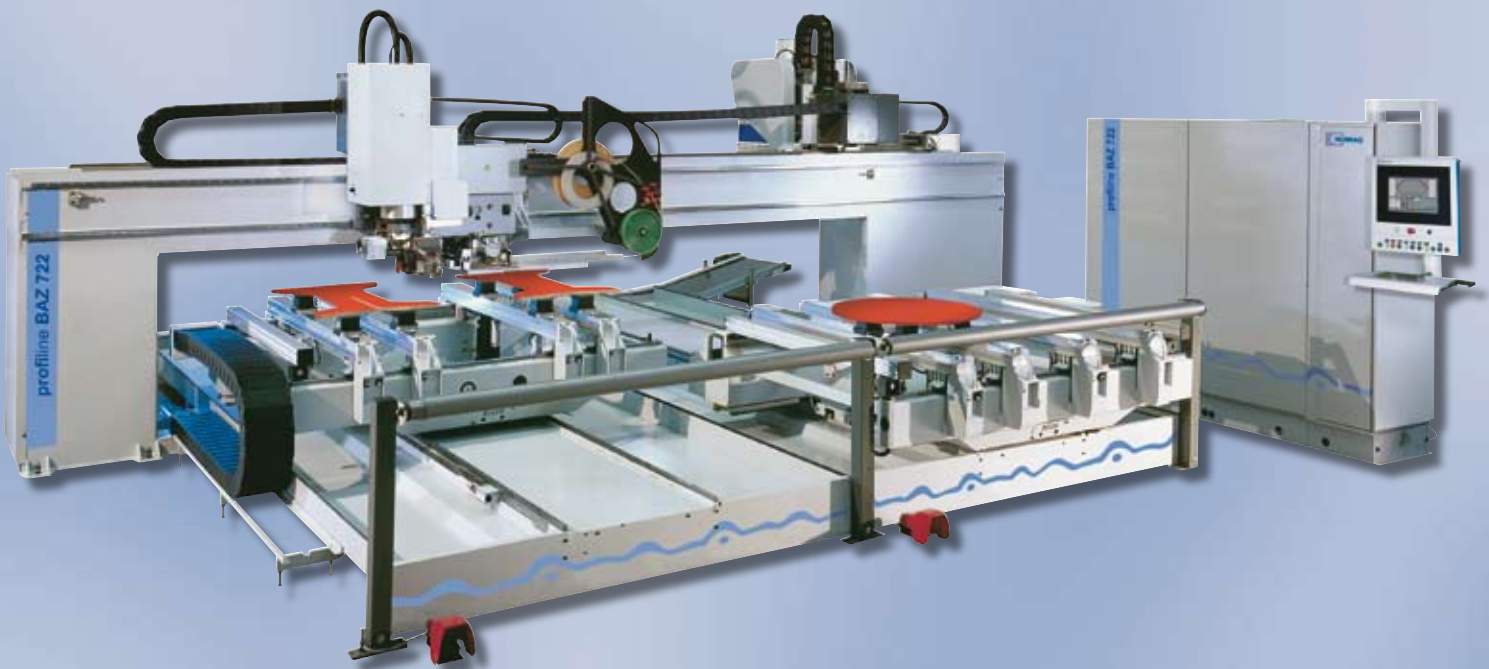

BAZ 722

B700: Compact and reliable

The gantry design saves space and also cuts out the need for the operator to cover long distances, as the work areas of both tables are located directly adjacent to each other. The patented safety monitoring eliminates the space required for safety devices such as safety tread mats.



Our innovative drive – your profit

1. Built-up edges in half the time

A new, highly economical built-up edge process designed specifically for furniture components.

- Built-up edges and edge application on a single machine in just one pass
- The built-up edge is divided off the workpiece panel and turned over
- Reduced manufacturing costs and simplified handling

2. EXKA – the economical way to achieve top quality

A totally new process for direct extrusion of plastic edges onto lightweight panels.

- Low-cost solution for wide-ranging fields of application
- Benefits: positive locking connection without glue joint, large profile depth, also for new design scope

3. DoubleEdge edge banding on lightweight panels in a single work operation

Support and décor edges are joined in the gluing unit and then applied to the panel.

- This permits the processing of shaped components up to 80 % faster
- The benefits of throughfeed plants: Space and cost savings due to compact design

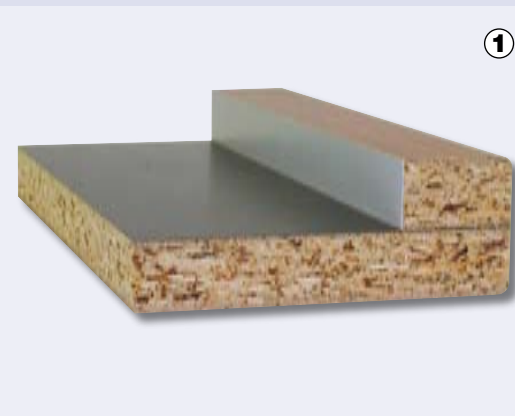

①



②



③



④



⑤

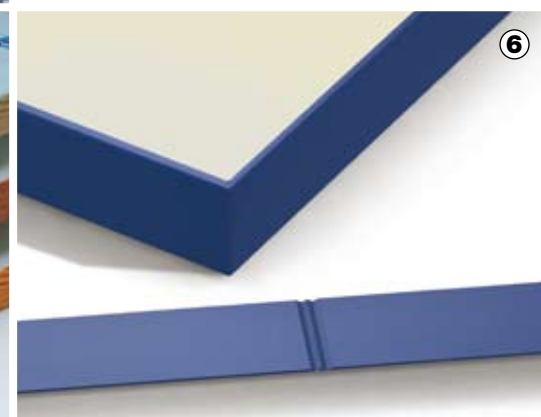

⑥

4. More profit when panel coating

with **complete** line, the new patented high-performance technique for coating (chipboard) panels on all sides.

- Improved workpiece quality: Elimination of glue joints, seamless continuous decor on edges and surfaces, impeccable edge finish, extreme impact resistance
- Maximum economy: Fast production, use of lower-cost raw materials

5. High-tech edge printing in four-color technology

Respond quickly to new design trends. Or even create your own. **print** line has made this easier than ever before. This new machine concept offers a whole range of benefits. You benefit overall from outstanding flexibility, lower costs and lower production input

6. Edge folding

This process permits the edging of rectangular workpieces on a processing centre in a single work process.

- A thick edge, e. g. made of 2 mm PVC, can be banded around a 90 degree workpiece by sawing into the back of the edging
- The achievable time savings amount to as much as 5 % per workpiece. Butt joints at the workpiece corners are also effectively eliminated

Your success guaranteed: The HOMAG service package

No matter which machine or which system you buy from us – you are investing in productivity and sure success in the long term. This is guaranteed not only by our engineering excellence but also by our seamless all-round support package which leaves you free to concentrate on what you do best and keeps your production up and running. The result: enhanced productivity and a sharper competitive edge. The bottom line: You save not only precious time but hard cash too.

Success through perfect planning

- We provide competent advisory support: right from day one
- You find the best possible, most economical solution to your requirements

Success through custom tailored financing

- We offer a range of attractive financing possibilities
- You leave your capital base intact

Success through a fast start up

- We take care of installation and commissioning
- You can get your production up and running straight away

Success through competent operation

- We train your staff and bring them up to speed
- You realize your machine's full potential

Success through continuous support

- We provide in-process support and machine optimization
- You gain from maximum productivity

Success through reliable function

- We offer preventive maintenance by video/remote diagnosis
- You have the assurance of absolute production reliability

Success through efficient support

- We ensure a fast, reliable repair and spare parts service
- You avoid unnecessary production standstill

Success on every continent

- We guarantee the worldwide availability of our services
- You are in capable hands – wherever you need us

HOMAG's **lifeline I** service ensures optimum availability and economical production – over the entire life cycle of your machine.



lifeline I service



HOMAG Holzbearbeitungssysteme AG

Homagstraße 3-5
72296 SCHOPFLOCH
GERMANY

Phone: +49 7443 13-0
Fax: +49 7443 13-2300
E-Mail: info@homag.de
Internet: www.homag.com

