

OMET LINEAR MOTION

ENGLISH VERSION

Aggiornato 23-01-06



THE PHILOSOPHY OF "OMET LINEAR MOTION"

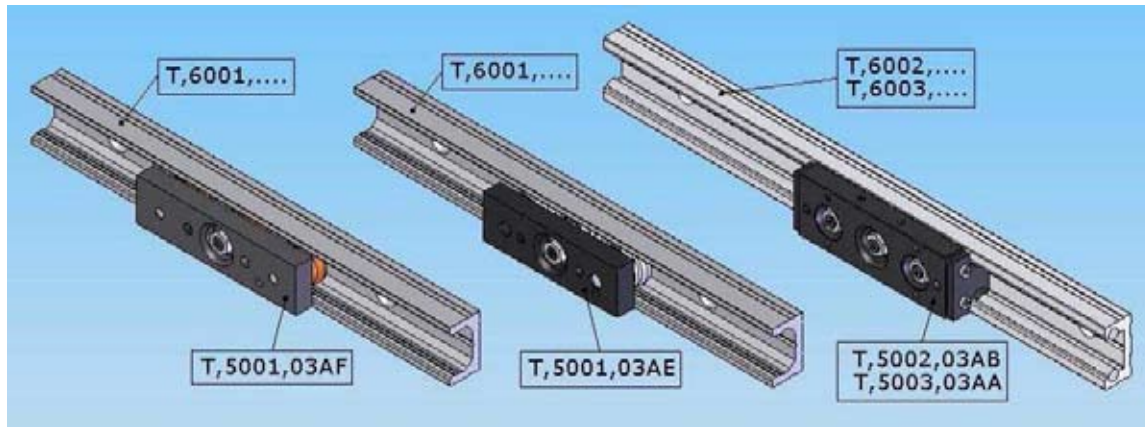

OMET proposes three ranges of complete modules aiming at satisfying the most varied needs in the field of linear motion. From the most economic to the most performing one, everything is to be evaluated according to the application.

The system is composed of a pivot-pin cursor (adjustable central pin) sliding inside a C-shaped rail with inner sliding rails.

The prominent features common to all ranges are:

- **ASSEMBLY SIMPLICITY**

All the rails are provided with fastening holes so that the assembler does not have to make any further operation. If the application requires supplementary holes on the rail, a special "reference groove" allows the point self-centering.

- **COMPACT DIMENSIONS, LIGHTNESS AND LONG LIFE**

The rails have sliding races in internal position and are therefore protected by accidental external impacts. The coupling cursor-rail has a very compact design. The rails and cursors are in aluminum alloy, which confers the system extreme lightness.

In the case of the models T,6002,.... e T,6003,.... , the rails are made by coupling a supporting element in aluminum alloy with hardened and ground steel bars that make up the sliding surface. The aluminum extruded profiles are stabilized and anodized.

- **INTERCHANGEABILITY AND CLEARANCE ADJUSTMENT**

OMET supplies the cursor-rail system already provided with the most suitable adjustment to guarantee the declared features. The same customer, in the assembly phase, can anyway easily intervene to adjust the clearance. This means that the cursors can be adapted in any rail (clearly of the same typology) and then cursors and rails can be ordered and stocked separately and "adjusted at the moment" according to the needs of the application.

- **INFINITE APPLICATION POSSIBILITIES**

The simplicity and cheapness of our systems allowed us to work out solutions in various sectors:

- machines for wood processing
- handling in general
- casings in general
- palletizers
- small automations
- automatic gates
- protection heads for machine tools
- automation in general

Our technical service cooperates with the customers to choose the optimal solution for each specific application.

PRODUCT LIST

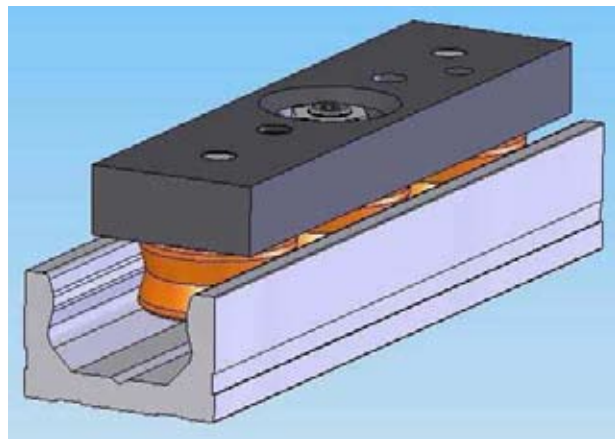

OLM-A SYSTEM **CURSOR T,5001,03AF** **RAIL T,6001,....**

LINEAR SYSTEM COMPOSED OF:

- Aluminum rail
- Cursor with 3 plastic-coated bearings with one ball crown

APPLICATIONS

Anywhere problems connected with low-speed motions shall be solved economically and where no motion precision is required

Example: manual motion in general, light casings, accident-prevention guards, doors, ...

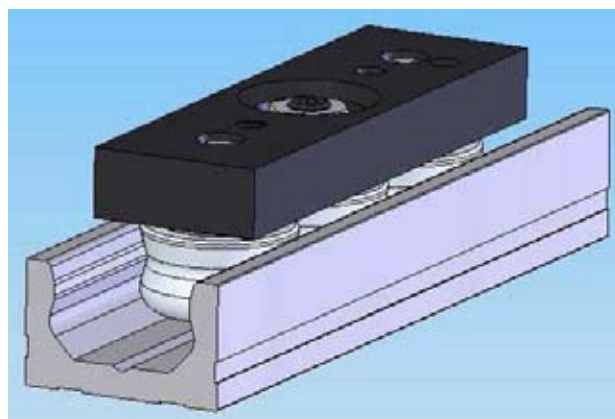

OLM-B SYSTEM **CURSOR T,5001,03AE** **RAIL T,6001,....**

LINEAR SYSTEM COMPOSED OF:

- Aluminum rail
- Cursor with 3 plastic-coated bearings with double ball crown

APPLICATIONS

Motions with higher speeds and precisions

Example: light casings, small automations, ...

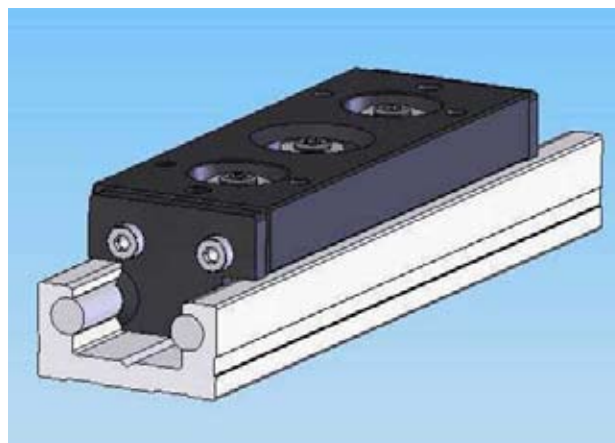

OLM-C SYSTEM **CURSOR T,5002,03AB - T,5003,03AA** **RAIL T,6002,.... - T,6003,....**

LINEAR SYSTEM COMPOSED OF:

- Aluminum rail coupled with steel bars making up the sliding surfaces
- Cursor with 3 steel bearings with double ball crown

APPLICATIONS

Precision motions with heavier loads and higher speeds

Example: automatic doors, heavy protection doors, palletizers, automation in general, secondary axes of packing machines, packaging, ...

OLM-A SYSTEM

Code T,6001,....

RAIL

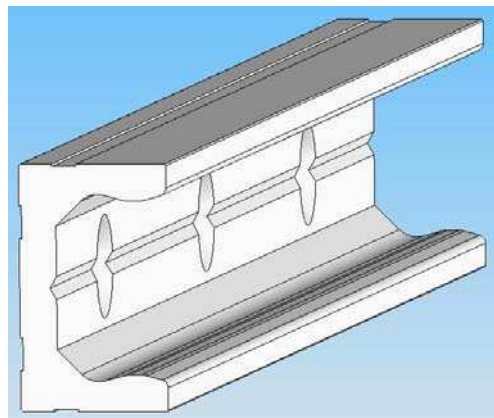

MATERIAL: Extruded and stabilized precision aluminum alloy

SURFACE TREATMENT: Grey anodizing

FASTENING HOLES: OMET standard drilling.
A special reference groove aids self-centering of the point to be drilled, in case additional holes are required.

Code T,5001,03AF

CURSOR

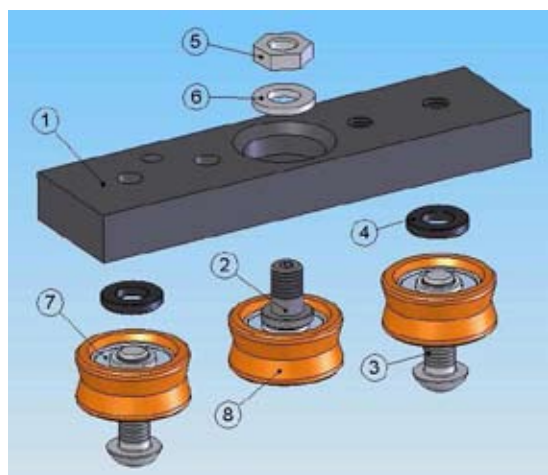

POS.	DESCRIPTION	MATERIAL	TREATMENTS
1	Cursor body	Aluminum alloy	Black anodizing
2	Central eccentric pin	Steel	Burnishing
3	Screws	Steel	Burnishing
4	Spacer	Steel	Burnishing
5	Nut	Steel	Zinc-coating
6	Washer	Steel	Burnishing
7	Bearing	Steel 100Cr6	-
8	Coating	Modified polyamide	-

OLM-A SYSTEM - TECHNICAL DATA

RAIL

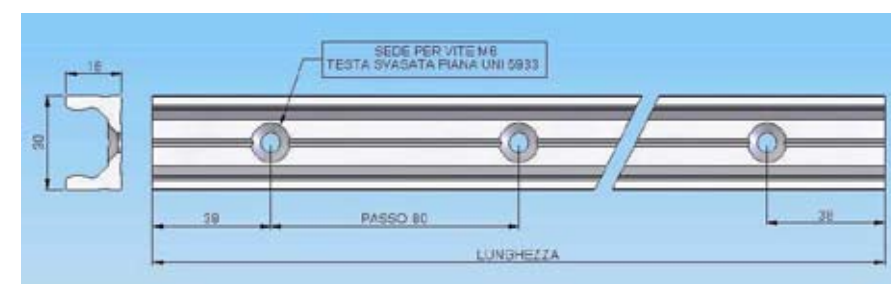

ORDER CODE	LENGTH	COUPLING WITH CURSOR
T,6001,104B	1036	T,5001
T,6001,200B	1996	
T,6001,296B	2956	

CURSOR

CODE T,5001,03AF

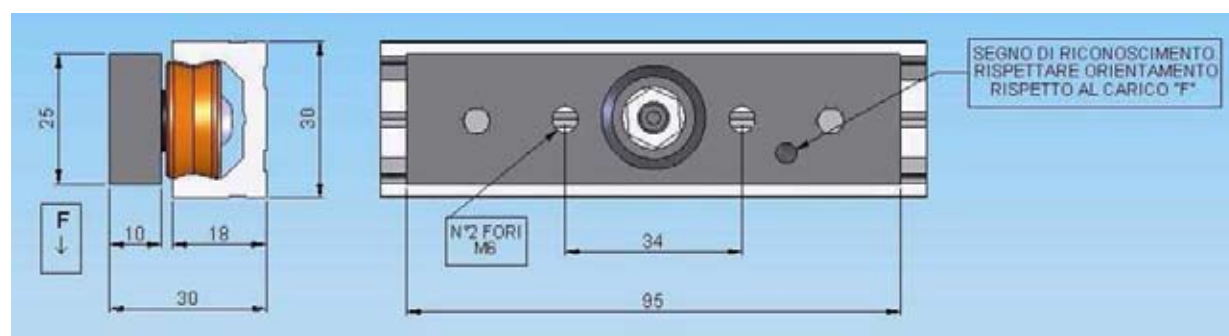

NOTE: Observe the orientation of the recognition sign with reference to the load F (on the same side where the loads works)

CAPACITY

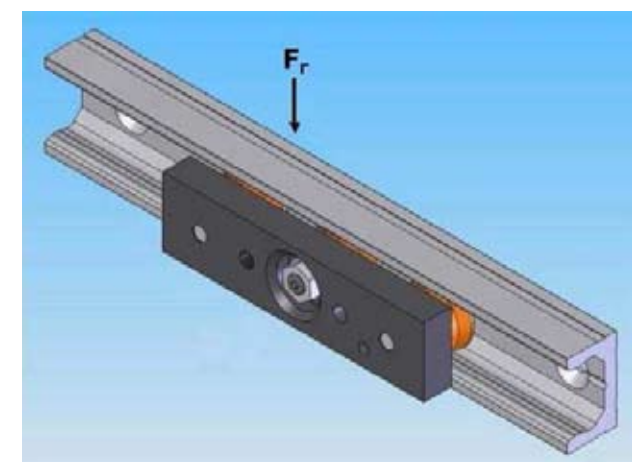

CODE	Fr (N)
T,5001,03AF	200

An optimal working is obtained using 4 cursors (see [customized loading tests](#)). It is not advisable to use the system on applications with axial loads.

OLM-B SYSTEM

Code T,6001,....

RAIL

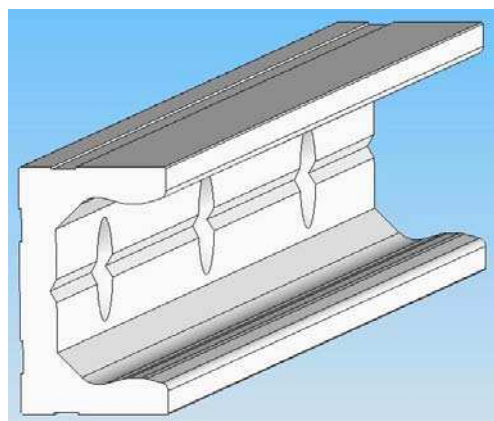

MATERIAL: Extruded and stabilized precision aluminum alloy

SURFACE TREATMENT: Grey anodizing

FASTENING HOLES: OMET standard drilling.
A special reference groove aids self-centering of the point to be drilled, in case additional holes are required.

Code T,5001,03AE

CURSOR

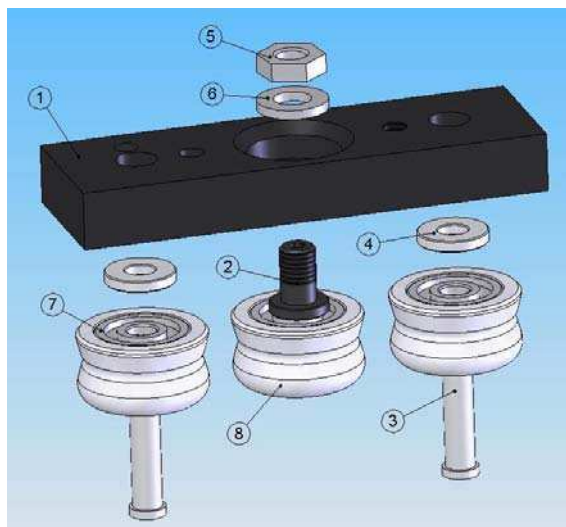

POS.	DESCRIPTION	MATERIAL	TREATMENTS
1	Cursor body	Aluminum alloy	Black anodizing
2	Eccentric central pin	Steel	Burnishing
3	Side pins	Steel	Burnishing
4	Spacer	Steel	Burnishing
5	Nut	Steel	Zinc-coating
6	Washer	Steel	Burnishing
7	Bearing 2RS	Steel 100Cr6	Hardened ground
8	Outer ring	POM	-

OLM-B SYSTEM - TECHNICAL DATA

RAIL

CODE T,6001,...

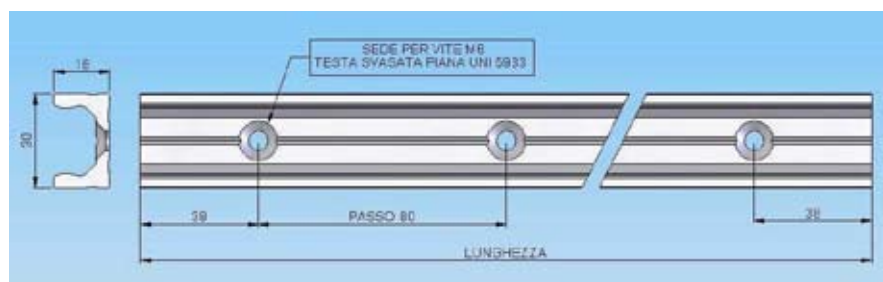

ORDER CODE	LENGTH	COUPLING WITH CURSOR
T,6001,104B	1036	T,5001
T,6001,200B	1996	
T,6001,296B	2956	

CURSOR

CODE T,5001,03AE

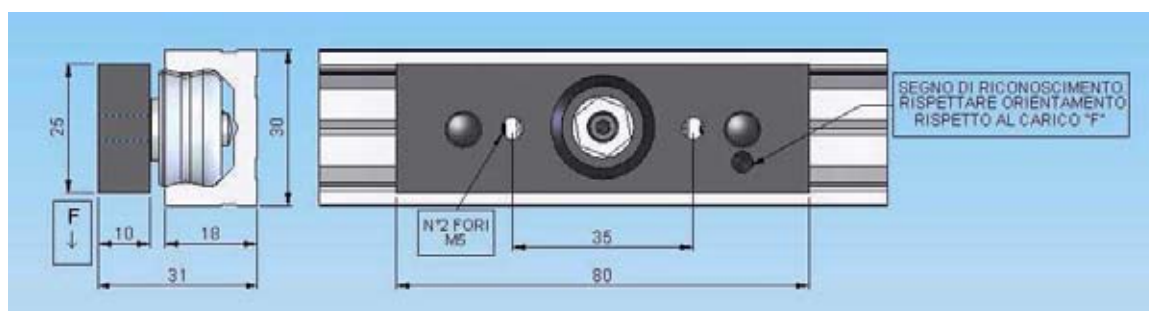

NOTE: Observe the orientation of the recognition sign with reference to the load F (on the same side where the loads works)

CAPACITY

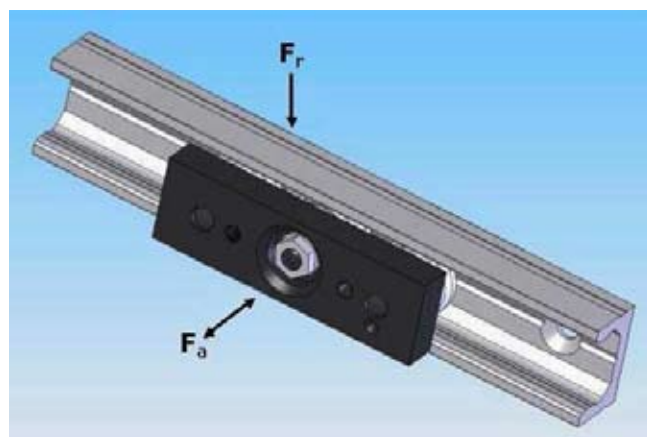

CODE	Fr (N)	Fa (N)
T,5001,03AE	350	200

An optimal working is obtained using 4 cursors (see [customized loading tests](#)).
It is advisable to assemble the system so that the loads working on the cursor is of radial type (F_r).

OLM-C SYSTEM

- **Code T,6002,....**
RAIL SECTION 30 mm
- **Code T,6003,....**
RAIL SECTION 40 mm

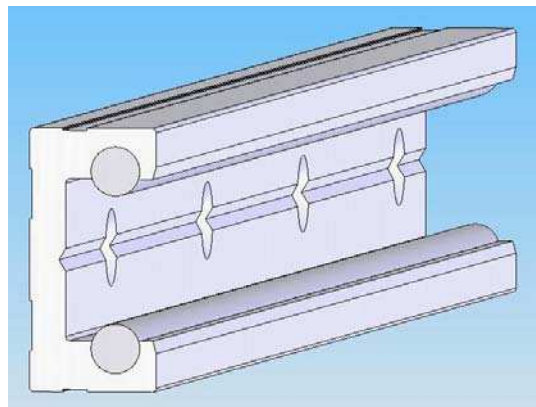

MATERIAL: Realized by coupling a supporting element in aluminum alloy with steel bars that make up the sliding surfaces. In such a way the most favorable features of both materials and the relevant processing technologies come to meet: the lightness of the alloy and the surface wear resistance of the bars. The rails in this family can fulfill structural functions; the high inertia moment allows using them as carrying structures in many accomplishments. The extruded aluminum profiles are stabilized and anodized. The sliding bars are hardened and ground.

FASTENING HOLES: OMET standard drilling. A special reference groove aids self-centering of the point to be drilled, in case additional holes are required.

- **Code T,5002,03AB**
CURSOR for rail section 30 mm
- **Code T,5003,03AA**
CURSOR for rail section 40 mm

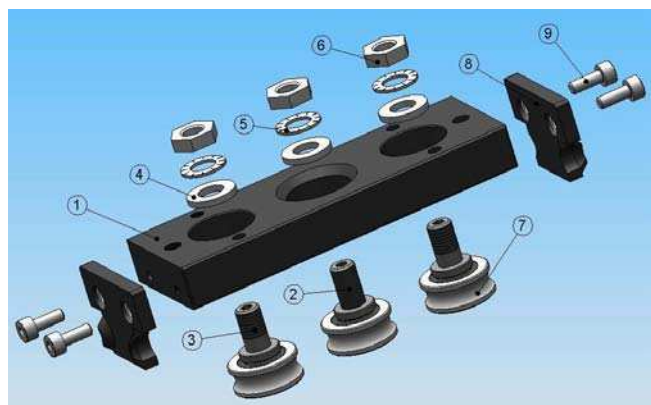

POS.	DESCRIPTION	MATERIAL	TREATMENTS
1	Cursor body	Aluminum alloy	Black anodizing
2	Eccentric central pin	Steel	Burnishing
3	Side pins	Steel	Burnishing
4	Washer	Steel	Burnishing
5	Knurled lock washer	Steel	Burnishing
6	Nut	Steel	Zinc-coating
7	Bearing 2RS double ball crown	Steel 100Cr6	Hardening + grinding
8	Race-cleaners	Steel core over-pressed in polyurethane	-
9	Screws	Steel	Burnishing

OLM-C SYSTEM - TECHNICAL DATA

RAILS

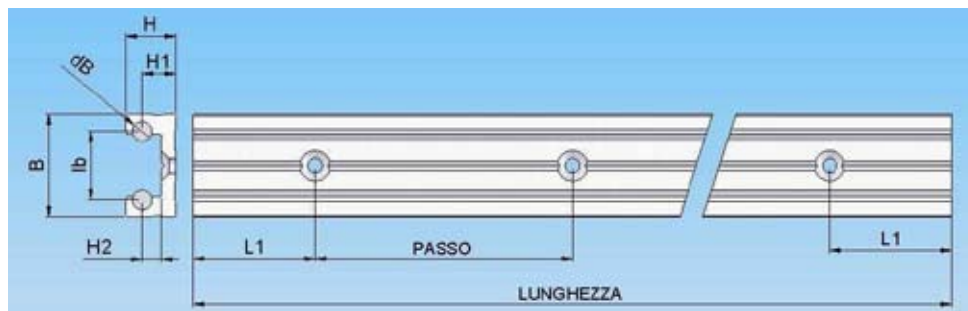

OLM-C
30 mm

OLM-C
40 mm

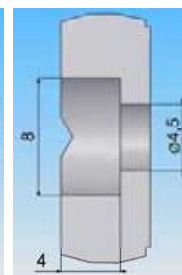
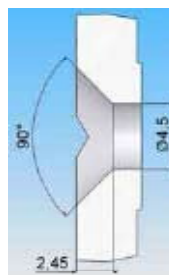

Type	ORDER CODE	Length	Dimensions (mm)								Coupling with cursor
			L1	B	H	H1	H2	Ib	dB	Pitch	
OLM-C 30 mm	T,6002,104B	1036	38	32	15,5	10,5	6,1	21,5	6 h7	80	T,5002
	T,6002,200B	1996									
	T,6002,296B	2956									
OLM-C 40 mm	T,6003,100A	996	48	42	20	14	8	29	6 h7	100	T,5003
	T,6003,200A	1996									
	T,6003,300A	2996									

CURSOR

CODE T,5002,03AB - T,5003,03AA

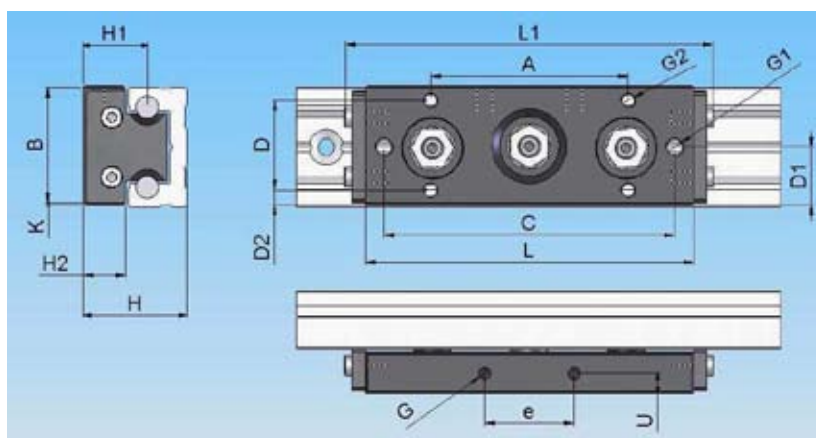

ORDER CODE	L	L1	A	C	e	U	G	G1	G2	D	D1	D2	H	H1	H2	B	K
T,5002,03AB	88	99	53	78	24	5,5	M4 prof.6	M5	M4	24	15,5	4	27,5	17	11	32	0,5
T,5003,03AA	105	116	73	90	35	7	M5 prof.8	M6	M5	30	20	6	35,7	21,7	14	42	1

CAPACITY

Type	F _y N	F _z N	M _x Nm	M _y Nm	M _z Nm
OLM-C 30 mm	1000	330	4	6	10
OLM-C 40 mm	1800	520	7,6	15	26

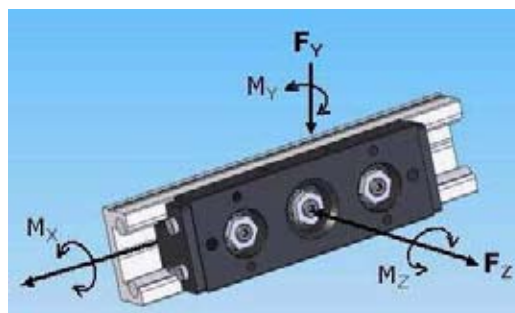

BALL BEARINGS FOR RAILS OLM-C

In order to meet with the variety of applications and allow the customer a larger customization possibility, OMET also proposes single components, leaving up to the designer how to make the most suitable cursor for one's own application.

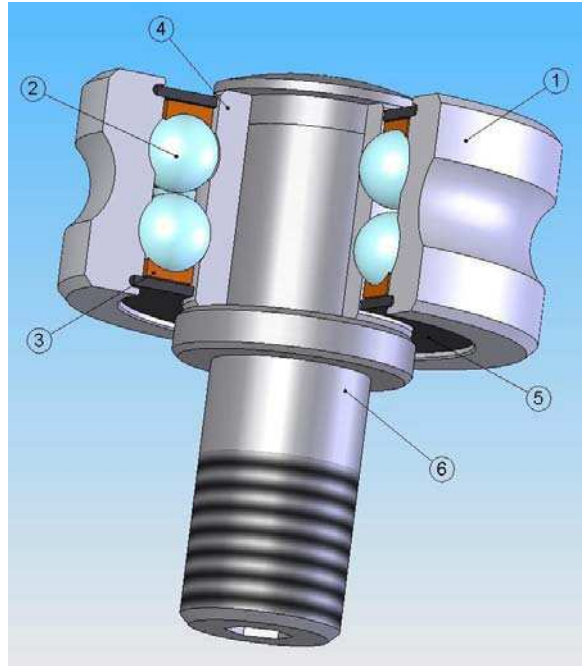

POS.	DESCRIPTION	MATERIAL	TREATMENTS
1	Outer ring	Steel 100Cr6	Hardening + grinding
2	Balls	Steel 100Cr6	Hardening + grinding
3	Cage	Steel	
4	Inner ring	Steel 100Cr6	Hardening + grinding
5	Dust cover double shielding	Plastic or iron	
6	Eccentric or Concentric pin	Steel	

BEARING

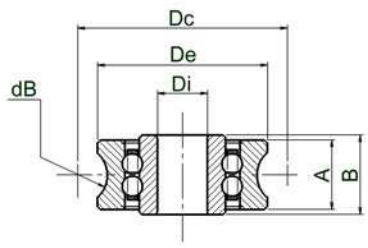

CONCENTRIC PIN

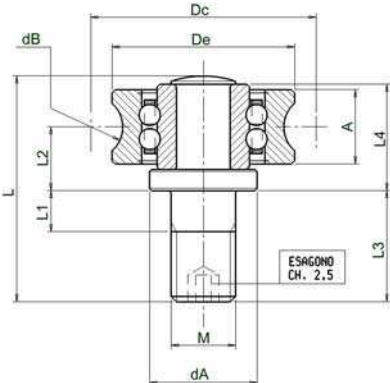

ECCENTRIC PIN

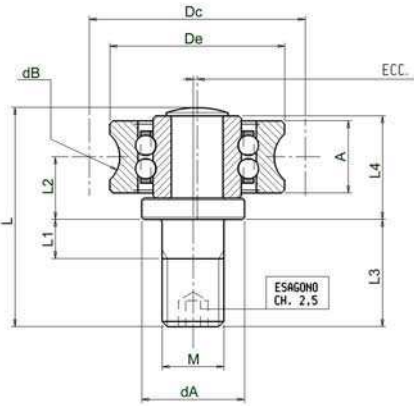

	DIMENSIONS (mm)													Coupling with	
	dA	dB	Dc	De	Di	A	B	L	L1	L2	L3	L4	M		
BEARING CODE: T,0248,AAGG	-	6	21	17	5	7	8	-	-	-	-	-	-		OLM-C 30 mm COD. T,6002
CONCENTRIC PIN CODE: T,0248,AEGG	10	6	21	17	-	7	-	21,2	3,8	6	10,4	10	M6		
ECCENTRIC PIN CODE: T,0248,ADGG	10	6	21	17	-	7	-	21,2	3,8	6	10,4	10	M6		
BEARING CODE: T,0248,AGGG	-	6	28	24	8	11	11	-	-	-	-	-	-		OLM-C 40 mm COD. T,6003
CONCENTRIC PIN CODE: T,0248,AHGG	12	6	28	24	-	11	-	27,3	5,3	7,7	13,3	13,2	M8		
ECCENTRIC PIN CODE: T,0248,AIGG	12	6	28	24	-	11	-	27,3	5,3	7,7	13,3	13,2	M8		

GENERAL INSTRUCTIONS FOR USE

• CONSTRUCTION PRINCIPLE OF THE CURSORS

The cursors are provided with 3 pivot-pins.

The two side pins are fixed and work on a side of the rail, the central one is eccentric and therefore adjustable. It works on the opposite side of the rail.

IMPORTANT

ARRANGE THE CURSOR SO THAT THE SIDE PINS LIE ON THE RAIL SIDE WHERE THE LOAD WORKS!

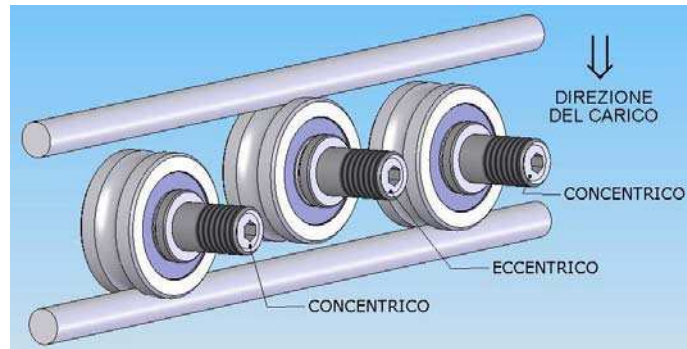

• SETUP OF THE CURSOR-RAIL CLEARANCE

The eccentricity of the central pin allows adjusting the pre-load and the cursor-rail clearance.

IMPORTANT

PAY THE MAXIMUM ATTENTION DURING THE SETUP PHASE: TOO HEAVY PRE-LOADS DRASTICALLY REDUCE THE LIFE OF THE LINEAR SYSTEM!

How to set: The adjustment of the eccentric pins shall be carried out rotating the shaft counterclockwise. In such a way any vibration that may occur during working will tend to tighten the threaded coupling.

1. Insert the cursor into the rail being sure that the fastening nut of the eccentric pin is lightly loosened so that a "forced rotation" of the pin itself is allowed.
2. Insert the socket head screw into the pin and rotate counterclockwise until the cursor-rail clearance is completely reset, anyway avoiding the pre-load.
3. Move the cursor evaluating pre-load and motion, which shall be sliding smoothly and not stick slipping, being sure that the cursor has no clearance in any point of the rail.
4. Lock the nut keeping the pin position fixed by means of the socket head screw.
5. Check the motion again, in negative case repeat setup.

NOTE: OMET supplies the product with the theoretically most suitable adjustment to guarantee the declared features.

LUBRICATION

- **BEARING LUBRICATION**

The bearings are life-long lubricated and shielded on both sides.

- **RAIL LUBRICATION**

As to the rail type OLM-A and OLM-B (completely in aluminum) no kind of lubrication is required, since the occurring contact is plastic (bearing coating) on aluminum.

For the rails type OLM-C (aluminum rail with steel insertions) it is necessary to have a lubricating film on the bars to avoid a direct contact between the metallic surfaces and protect from corrosion.

The lubrication interval depends on a lot of factors among which temperature, speed and use conditions (loads, assembly of the rail so that the cursor slides more or less free). As an indication a re-lubrication is recommended every 50 Km run.

USE TEMPERATURES

All the tests carried out at OMET laboratory refer to room temperatures.

In general a working temperature included between -20 and $+60^{\circ}\text{C}$ is recommended, even if everything depends on the use conditions (speed, type of cycles, exposure time to such temperatures, ...)

ASSEMBLY INSTRUCTIONS

In the case of parallelly assembled rails it is important to check parallelism to avoid an overload of the bearings or a too high clearance of the cursor to compensate the parallelism error that theoretically does not have to be higher than a 0,1-0,2 mm.

After assembling the whole linear system it is recommended to let the cursor slide on the rails by hand. The motion shall prove to be soft and without hindrances. A wrong assembly heavily jeopardize the capacity features of the cursor-rail system.

CUSTOMIZED LOAD TESTS

OMET "Practical Test" laboratory is able to carry out customized tests. The final applications of the cursor-rail system are infinite and very different from one another.

- HORIZONTAL, VERTICAL AND OBLIQUE MOTIONS
- TYPE OF LOADS (axial, radial, moments)
- ACCELERATIONS (taking to dynamic loads due to inertia forces and creating instantaneous very heavy loads)
- RAIL ARRANGEMENT, NUMBER OF CURSORS, ...
- USE CONDITIONS

The above mentioned are only some of the features defining a linear system.

Noticeably in a laboratory it is not possible to recreate all these variables; there are testing machines anyway, conceived and designed by OMET, that can simulate various use situations. During the tests the parameters that might cause the life end of the cursor-rail system are constantly monitored.

Here are some examples:

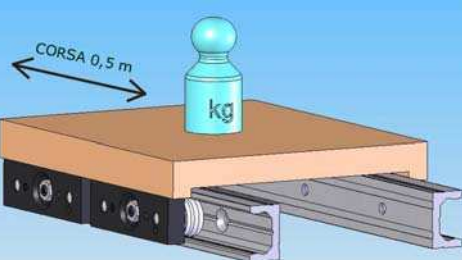
HORIZONTAL MOTION LOAD ON THE CURSOR: RADIAL	PRODUCT	CYCLES	SPEED (m/min)	COVERED Km AT TEST END	LOAD ON SINGLE CURSOR (Kg)
	T,5001,03AE	Continuous cycle alternate with motion reversions that do not create instantaneous loads	20	250	35

RESULT OF THE CONTROL
Minimal wear on the plastic ring that does not jeopardize the use.

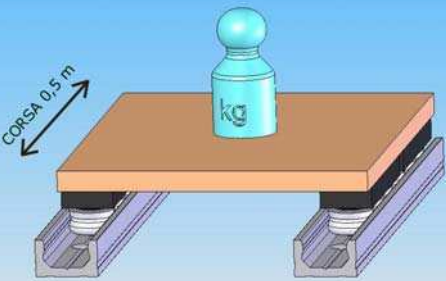
HORIZONTAL MOTION LOAD ON THE CURSOR: AXIAL	PRODUCT	CYCLES	SPEEDS (m/min)	COVERED Km AT TEST END	LOAD ON SINGLE CURSOR (Kg)
	T,5001,03AE	Continuous cycle alternate with motion reversions that do not create instantaneous loads	20	250	20

RESULT OF THE CONTROL
A minimal wear that does not jeopardize the use is noticed on the plastic ring after 40 Km. After 250 Km the cursor has not taken any type of clearance.

APPLICATIONS

OLM-A SYSTEM

CURSOR T,5001,03AF

RAIL T,6001,....



Application on casings sliding horizontally. Line-end protection of an automatic machine.

OLM-B SYSTEM

CURSOR T,5001,03AE

RAIL T,6001,....



Slide of a pneumatic follow-up link for rotary table.

OLM-C SYSTEM

CURSOR T,5002,03AB

RAIL T,6002,....

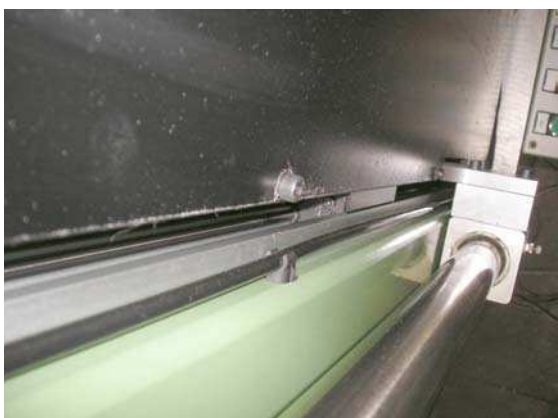

Application on a large-dimension bulkhead. The closing-opening cycle is frequent and on three shifts. The motion is entrusted to a shaftless cylinder.