

Gear pumps, screen changers and systems for the extrusion industry

Leaders in productivity

The world leader for proven processing solutions.

maag **pump** system

U

sing leading-edge technology makes sense. That's why Maag gear pumps are found all over the world in thousands of applications in the plastics and elastomer industry. And not without good reason – these pumps are based on decades of experience and continuous improvements and are designed around a flexible modular platform that offers innovative solutions that cut operating costs. Other Maag Pump Systems products are the ideal complement for this range. High efficiency screen changers make your products even purer, our control system and measuring technology further refine your processes and, in combination with our other components, can be put in as either retrofits or as new installations. Putting it all together, it's easy to see why Maag Pump Systems is the leading manufacturer of gear pumps, filtration systems, and associated controllers for the extrusion industry.

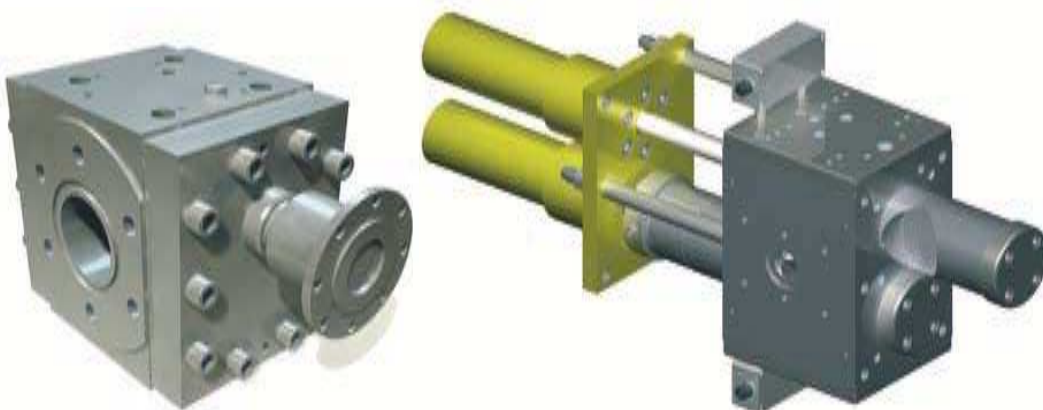

Making extrusion processes more efficient.

Gear pumps improve the extrusion of thermoplastics and elastomers by providing the required system pressure at the die head. This saves the extruder having to generate pressure, which in turn increases the overall line efficiency, improves the quality of the end product, and prolongs the useful service life of the extruder due to reduced melt temperatures and pressures on the extruder barrel and screw. What's more, pulsations and pressure peaks are flattened or even outright eliminated by the gear pump's smooth delivery and its dampening effect on the incoming and often erratic melt pressure from the extruder.

Gear pumps offer other benefits too. Any scrap or waste products upstream of the pump can be recycled and the melt's passage through the die head is extremely smooth, which reduces material gauge variation for less material usage and a consistently higher quality end product.

.....
While Maag doesn't make extruders, we make them *perform better*. Our products are typically used in ...:

- Cast film and sheet
- Tube and profile
- Cable and hose
- Blown film

.....
... applications.

Without gear pump

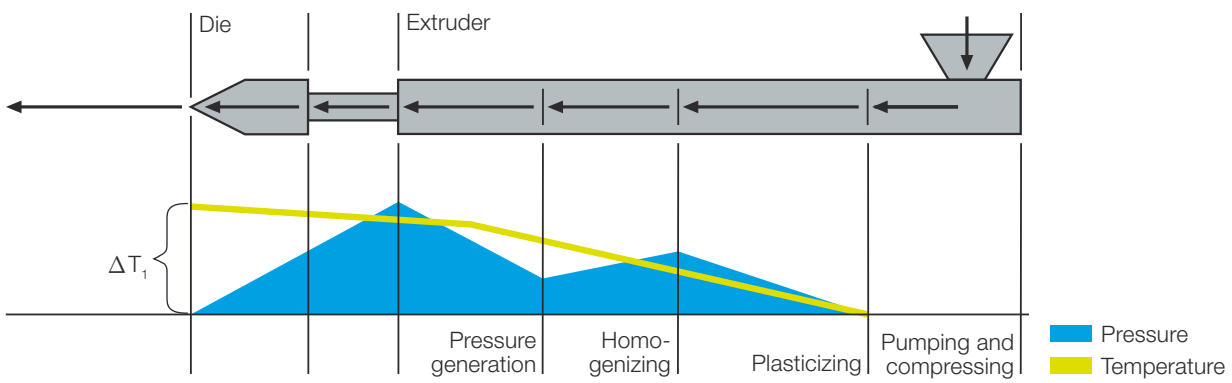

With gear pump

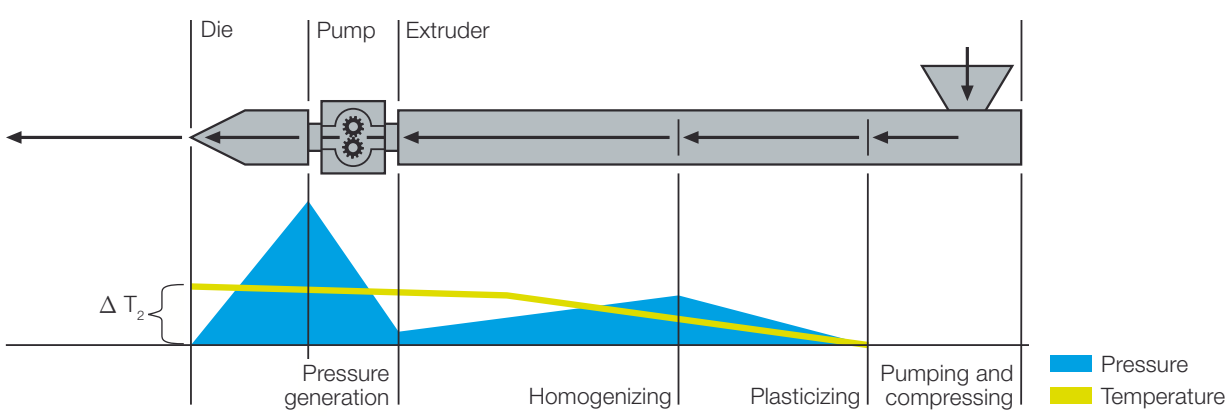



For constant volume pumping with minimal gauge variation

Long lasting, and highly efficient pumps for every process.

Maag Pump Systems gear pumps are positive displacement pumps for high pressure applications that increase the efficiency of your process. They are commonly found in processes as reactor feed, reactor discharge, and booster pumps for low and high-viscosity applications. Our expertise, developed from our close collaboration with our customers, is the key to our on-going product development. This greatly enhances the value, quality, and dependability we offer to the thermoplastic and elastomer processing industries.

Maag Pump Systems guarantees flow stability and consistency, even at maximum output pressures. And thanks to optimized internal flow geometries, we routinely handle pumping from near total vacuums and other extremely low inlet pressure conditions.

Maag Pump Systems has made a name for itself as a pioneer in the development of gear pumps. Reliability and quality are guaranteed by modern manufacturing methods and state-of-the-art working processes.

The extrex® gear pump is used in plastics and rubber applications that require extremely reliable pumping.

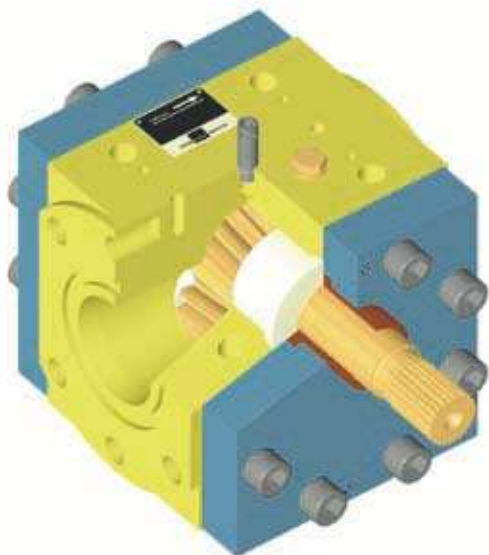

- Excellent filling and feeding characteristics due to optimized inlet geometries
- Efficient flow channels
- High working pressures
- High overall efficiency
- Very low pulsation pumping, even at high and varying differential pressures
- Minimal temperature rise

Some typical thermoplastics

Thermoplastics

- Acrylonitrile Butadiene Styrene
- HD/HMW Polyethylene
- LD/LLD Polyethylene
- Polyamide 6/66
- Polybutene
- Polycarbonate and PMMA
- Polyether Ether Ketone
- Polyethylene Terephthalate PET
- Polyisobutylene
- Polypropylene

- Polystyrene and HIPS
- Thermoplastic elastomers
- Various bonding agents
- Other polymers available upon request

Elastomers

- Acrylonitrile-Butadiene rubber
- Butadiene rubber
- Butyl rubber
- Chloroprene rubber
- Ethylene-Propylene rubber
- Ethylene Propylenediene rubber
- Isoprene rubber
- Natural rubber
- Silicone rubber, solid
- Styrene-Butadiene rubber
- Other elastomers available upon request

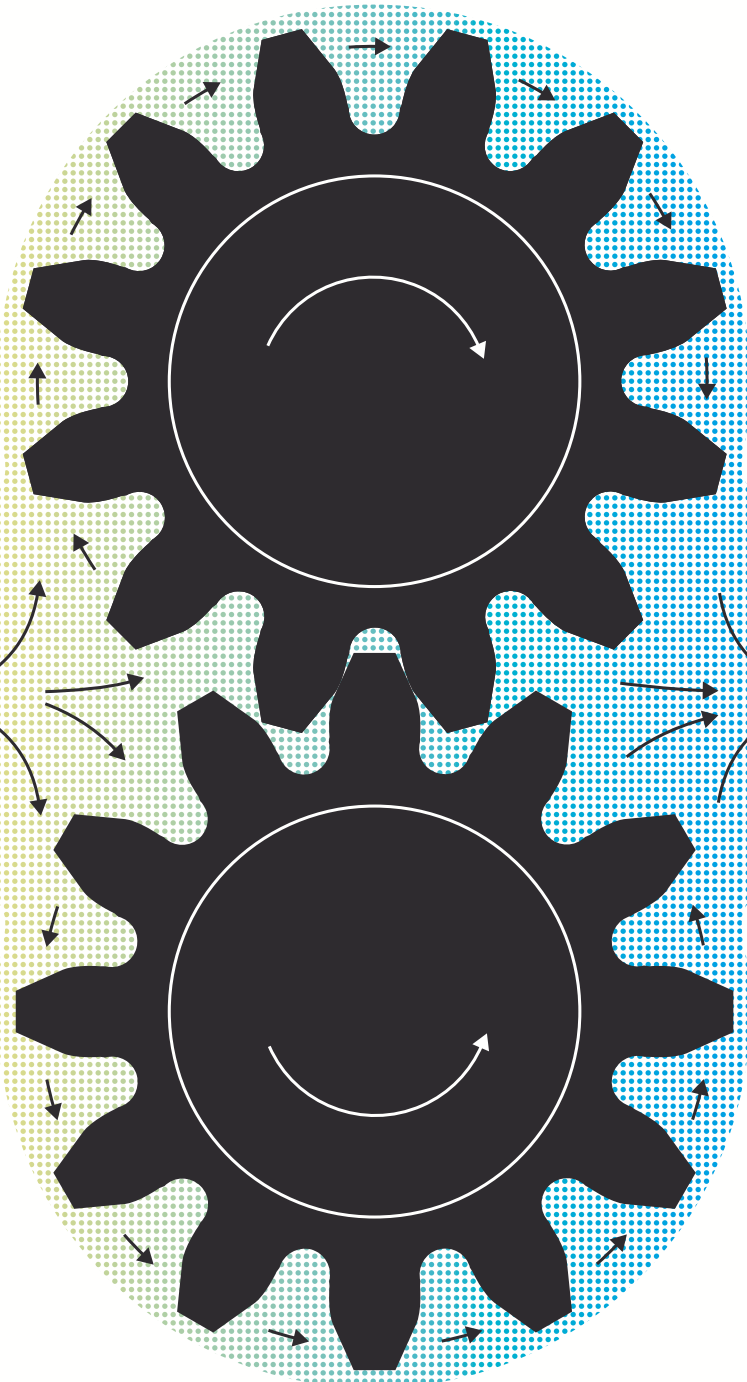

Gear pumps for thermoplastics. The extrex® is a modular gear pump designed to meet a broad spectrum of requirements in the simplest way. It is consistent with the quality, reliability, and long life that all Maag gear pumps are known for. All extrex® pumps have fully-optimized flow channel geometry, a new bearing design that enables faster speeds and higher throughput rates, expanded clearance classes to handle a greater range of viscosity and pressure conditions, and specially heat treated shafts that offer up to twice the life expectancy of comparable standard shafts.

The following features are also available with the extrex®:

- Pre-engineered clearance classes
- Heater cartridges fully-wired to connectors
- Liquid heating with port network
- Melt pressure/temperature sensor ports in the housing
- Application-specific materials
- Shaft seal cooling
- Special seals of various types

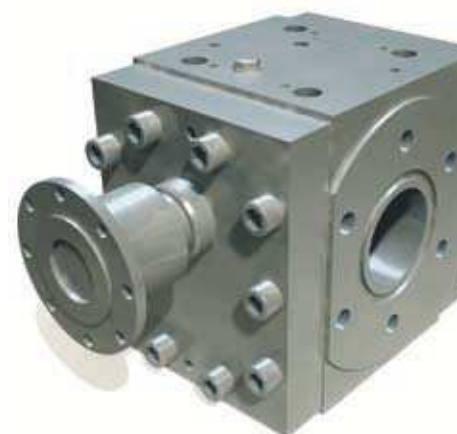

For all our extrex® gear pumps

Viscosity	to 30,000 Pas
Temperature	to 660 °F / 350 °C
Inlet pressure	to 1,750 PSI / 120 bar
Housing and cover	Alloy steel
Gear shafts	Tool steel
Bearings	Tool steel
Shaft seals	viscoseal
Pump heating	Electric or by fluid

extrex® GP – for a broad range of applications

Outlet pressure	to 5,075 PSI / 350 bar
Pump sizes	20 to 180
Specific volumes	1.3 to 3,224 cm³/rev
Throughput range	9 to 33,000 lb/hr 4 to 15,000 kg/h

extrex® HV – with 25% higher specific volumes than the extrex® GP

Outlet pressure	to 4,350 PSI / 300 bar
Pump sizes	56 to 90
Specific volumes	116 to 453 cm³/rev
Throughput range	175 to 8,800 lb/hr 80 to 4,000 kg/h

extrex® HP – for differential pressures to 5,800 PSI

Outlet pressure	to 7,250 PSI / 500 bar
Pump sizes	36 to 140
Specific volumes	15.6 to 959 cm³/rev
Throughput range	22 to 13,200 lb/hr 10 to 6,000 kg/h





Gear pumps for elastomers. Maag Pump Systems has

taken gear pump performance to new levels of cost effectiveness and engineering technology with our new extrex® RB/RV pump series. High output, minimal tolerance deviations, and quickly attaining process stability provide an impressive cost to benefit ratio. A newly developed inlet area supports the high conveying characteristics that are specific to gear pumps, thus increasing processing tolerances when it comes to filling, degree of plasticizing, and pressure build-up during mixture preparation. The end result is an extrusion line with much higher end product quality.

The following standard options are also available:

- Pressure/temperature sensor ports in housing
- Shaft cooling inclusive protection guard

extrex® RB – for high pressure elastomer applications

Outlet pressure	to 6,500 PSI / 450 bar
Pump sizes	56 to 110
Specific volumes	59 to 457 cm³/rev
Throughput range	110 to 2,200 lb/hr 50 to 1,000 kg/h

extrex® RV – for temperature-sensitive elastomers

Outlet pressure	to 5,075 PSI / 350 bar
Pump sizes	36 to 110
Specific volumes	25.6 to 718 cm³/rev
Throughput range	33 to 3,300 lb/hr 15 to 1,500 kg/h

Applicable to all elastomer gear pumps

Mooney ML 1+4 (100)	to 100
Viscosity	to 30,000 Pas
Temperature	to 265 °F / 130 °C
Inlet pressure	to 1,750 PSI / to 120 bar
Housing and cover	Alloy steel
Gear shafts	Tool steel / prepared for shaft cooling
Bearings	Tool steel
Shaft seals	viscoseal, outward pumping (application-specific)
Pump heating	by fluid



Filtration is critically important. How would you feel if a PET bottle of mineral water from a supermarket was visibly contaminated or if the water was less than crystal clear? Would you accept visible particles on the surface of your flat screen TV? Would you tolerate read or write errors caused by micro-contaminants on CD-ROMs you have burned yourself? Of course not.

Nowadays, we expect consumer products to meet extremely high standards when it comes to quality of workmanship and optical characteristics. A key component of manufacturing and processing plastics is therefore filtration, a process in which a filter separates contaminants from the liquid plastic melt.

Maag Pump Systems supplies the equipment required for filtration in every conceivable area of plastics processing. Continuous development activities improve these products, which in turn enhances customer satisfaction and delivers a quality that both producers and end consumers have come to expect.

The technology behind Maag Pump Systems screen changers is based on 25 years of experience, many worldwide patents, and long-standing customer confidence. Our equipment is used in many standard extrusion applications, as well as special purpose applications involving critical materials or special production processes with huge throughput rates.

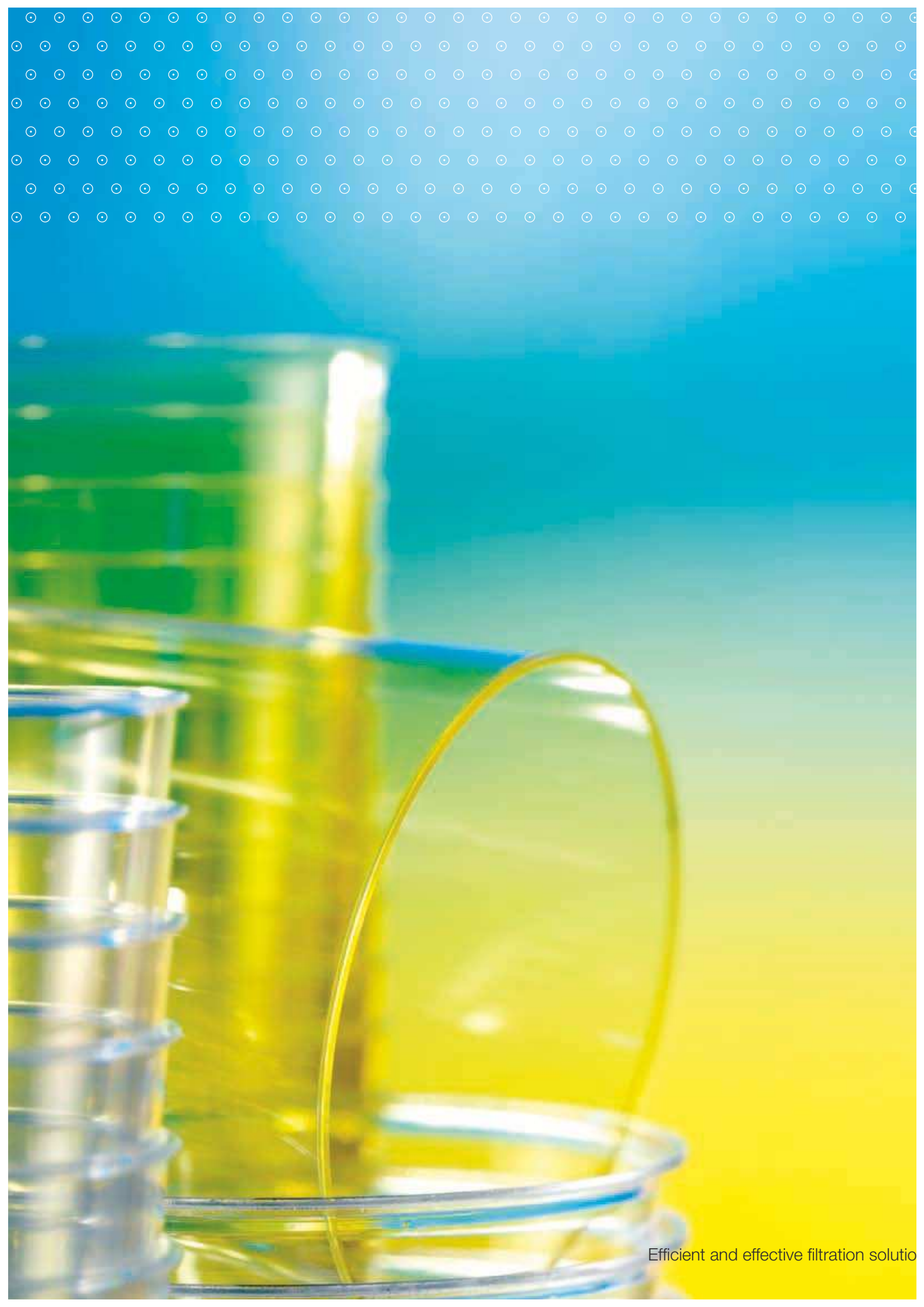

Efficient and effective filtration solution

The two basic types of screen changers. With their constant processing design, CSC type continuous screen changers are able to meet the most stringent quality requirements for melt filtration. Type HSC, FSC and DSC discontinuous screen changers are a simple, robust, and affordable alternative for applications where a short interruption in the melt flow is acceptable for making screen changes.

The DV continuous divert and dump valve was developed specifically to meet the requirements of underwater pelletizing. It features a unique design that provides bumpless changeovers and eliminates the possibility of a deadhead condition.

Maag Pump Systems screen changers offer many benefits to your process:

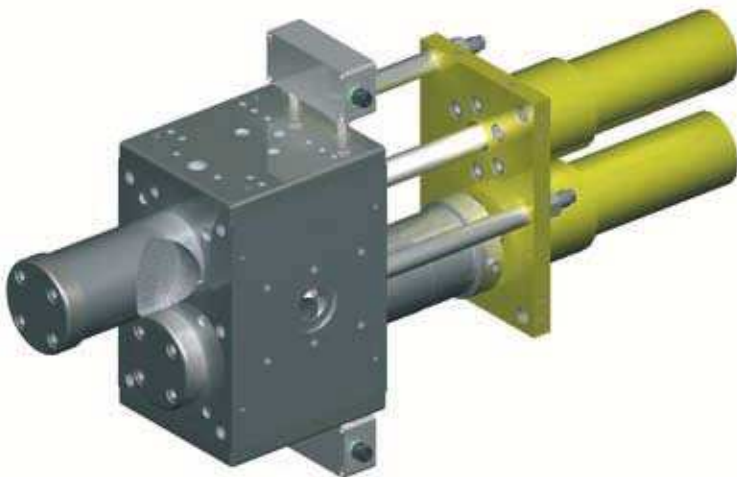

- Rheologically-optimized flow channels
- Short material residence times
- Fast color changeouts
- Reduced pressure requirements
- Simple start-up and operation
- Faster screen changes
- Leak-free operation
- Reliable venting
- No seals or parts to wear
- All installation positions possible
- Compact design

CSC – the classic. This basic version of our double piston screen changer is provided with the following dimensions and specifications.

- Screen diameters 1.25 to 20 inches / 30 to 508 mm
- Screen surfaces 1.85 to 630 in² / 12 to 4,052 cm²
- Working temperature 625 °F / 330 °C
- Working pressure 7,250 PSI / 500 bar
- Differential pressure 1,400 PSI / 100 bar

Special CSC melt filters in a high-temperature, high pressure and stainless steel design are also available for special polymers or to meet new process requirements.

.....
 Each piston is equipped with a screen plate, support plate and wire mesh screen.

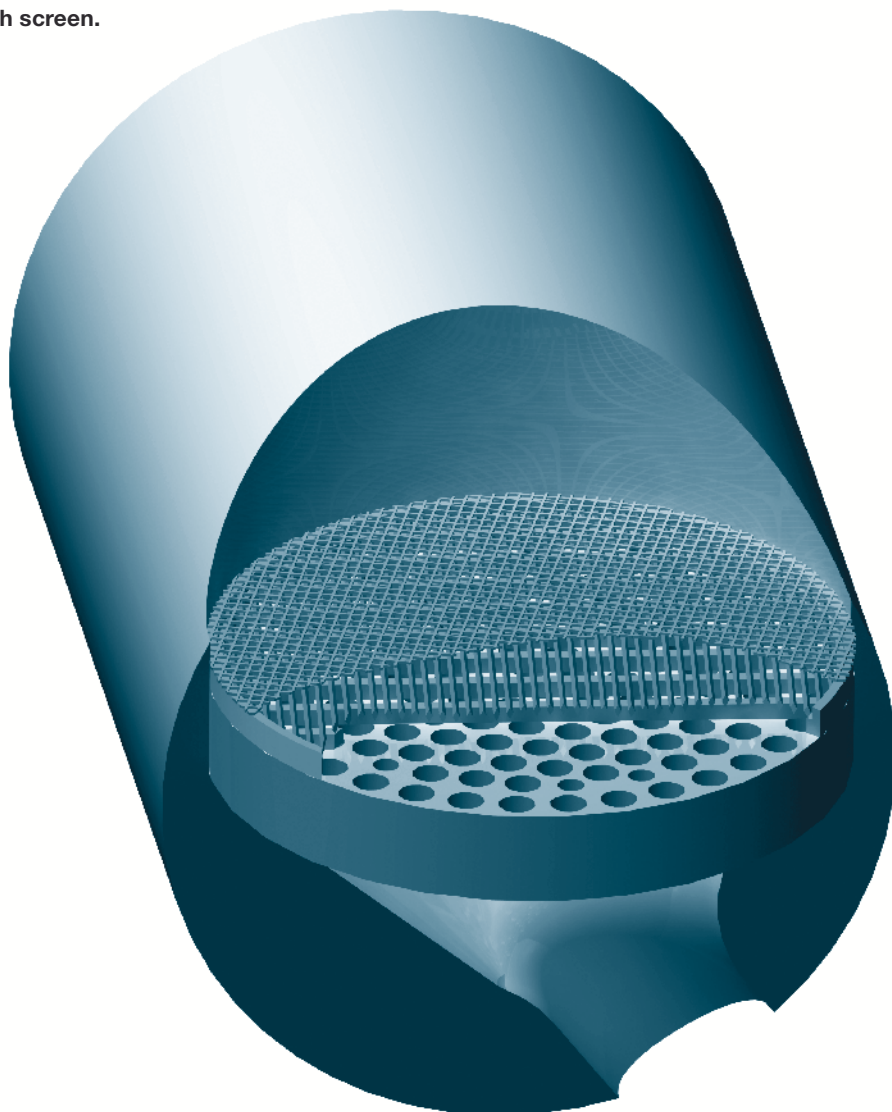

Maag piston screen changers can also be fitted with candle filters for much larger filter area. The complete candle filter assembly can provide a filtering surface of up to 160 ft² / 15m².

The discontinuous screen changer



with swivel plate: HSC

Screen diameter	1.18 to 5.88 inches 30 to 150 mm
Screen surface	1.0 to 27 in ² 7 to 177 cm ²
Working temperature	660 °F / 350 °C
Working pressure	10,150 PSI / 700 bar
Differential pressure	2,900 PSI / 200 bar

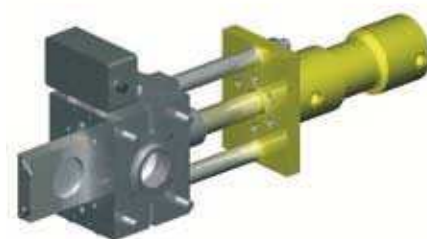

with slide plate: FSC

Screen diameter	2.25 to 10.25 inches 58 to 260 mm
Screen surface	4.0 to 82.3 in ² 26 to 531 cm ²
Working temperature	660 °F / 350 °C
Working pressure	10,150 PSI / 700 bar
Differential pressure	2,900 PSI / 200 bar



with screen bolt: DSC

Screen diameter	1.25 to 15.75 inches 30 to 400 mm
Screen surface	1.0 to 194.7 in ² 7 to 1,256 cm ²
Working temperature	660 °F / 350 °C
Working pressure	7,250 PSI / 500 bar
Differential pressure	1,450 PSI / 100 bar



with divert valve: DV

Screen diameter	1.0 to 3.94 inches 25 to 100 mm (bore)
Screen surface	–
Working temperature	660 °F / 350 °C
Working pressure	7,250 PSI / 500 bar
Differential pressure	–

The automation and controls of the expac® systems. Along with components for pumping and filtering plastics and elastomers, Maag Pump Systems also offers complete automation packages with the necessary transducers and control components to link everything together. This makes a big difference in process control. Integrated statistical functions and process data memories permit transparent quality management and control. The higher the number of parameters controlled, the more productive and safer the overall operation.

What is pump inlet pressure regulation?

The pump inlet pressure regulator synchronizes the extruder throughput with the pump. This enables 100% filling of the pump and guarantees constant pumping.

Maag Pump Systems supplies customized controllers that allow either the extruder speed or the pump speed to be selected as the variable. With our controls entire systems can also be linked and integrated into the overall plant control.

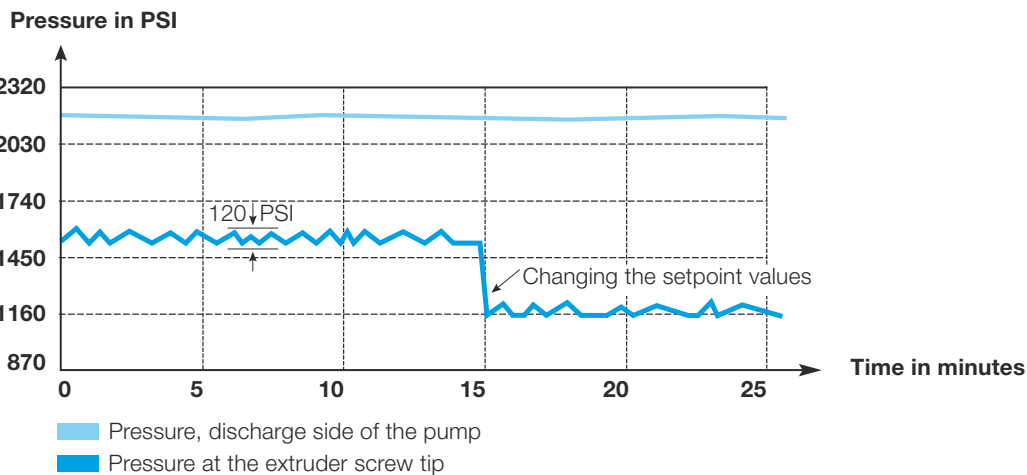



Automation adds to your process transparency while minimizing total operating cost

Automated measuring technology processes offer more.

The maax® 9 and 60 automation systems from Maag are ideally suited for retrofitting into extrusion and compounding lines that use a melt pump. Central operation, optimized control circuits and continuous monitoring by the maax® 9 and 60 significantly improves the quality of the end product.

The standard version of the maax® 9 covers a broad range of applications and provides a production flow under monitored and reproducible conditions. Equipped with standard software, the maax® 60 provides additional capabilities and features.



maax® 9

- Convenient, safe operation via color monitor with touch screen
- Integrated manual operating level
- Integrated melt pump controller
- Automatic start up and shut down of the entire line
- 10 temperature zones
- Continuous quality monitoring of process variables
- Fast error recognition with plain text messages
- Configurable regulation function for the pump inlet pressure
- On-line combined listening and speaking key
- Printer connection via LPT
- Integrated filter monitoring



maax® 60

- Convenient, safe operation via color monitor with touch screen and keyboard
- Integrated manual operating level with ergonomic speed adjustment via a rotary pulse encoder
- Integrated melt pump controller
- 20 or 30 temperature zones, standard version can be upgraded
- Integration of drives synchronized by downstream devices
- Automatic start up and shut down of the entire line
- Continuous quality monitoring of process variables
- Fast error recognition with plain text messages
- Freely-configurable regulation function
- Online combined listening and speaking key
- Host computer and printer connection via serial interfaces
- Remote monitoring and error diagnosis by modem

Automation for extruders. Maag Pump Systems offers a broad range of pressure and temperature sensors and displays for extrusion and compounding applications. The complete expac® package from Maag is rounded out by measuring components, melt pumps, screen changers, and controllers.



Pressure sensors

- Isolated by a non-wearing membrane, corrosion-proof design and EMC safety.
- For measuring ranges of 2,900 to 10,150 PSI; 200 to 700 bar
- Melt pressure sensor
- Melt temperature probe

Readers and plotters for pressure and temperature

- Full range of accessories
- Complete electrical system supplied with automation system

Static mixers

- Our standard, pre-engineered thermoprofiler and static mixers provide cost-efficient mixing at least two fluid streams. Our custom design blendrex® mixing elements continuously split the delivered flow, remix it, homogenize it, and symmetrically set the melt's temperature gradients to assure even mixing, uniform addition dispersion, and temperature profile consistency.

expac® – retrofitting for extrusion lines. expac®

systems are designed for new lines or retrofitting into existing ones. They can be supplied as individual components or fully-mounted on a mobile or stationary base frame. Such a system typically consists of:

- Drive system with gear motor and universal drive shaft
- Gear pump
- Controller built into a switch cabinet
- Appropriate instrumentation
- Interfaces with existing plant controls
- Capability of integration with a screen changer
- Supply and design of all required mechanical assemblies and parts, including piping, flanges, and frames.
- Supply and integration of melt filtration system controls
- Installation of electrical and mechanical assemblies
- Process optimization and guidance
- Cost-efficiency analysis

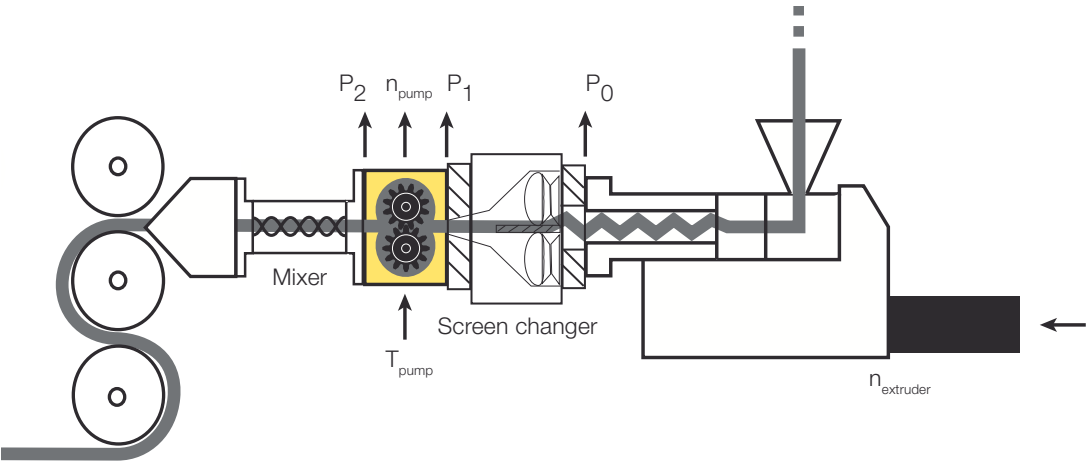

Various negative process effects, such as extruder pulsation from wear or the internal recycling of feed material can cause dimensional deviations of the end product. The expac® system dramatically reduces these variances, ultimately improving your end product quality.

expac® pays off – a calculation example

A 6 inch diameter PE pressure pipe with a 3/8 inch nominal wall thickness is produced with and without expac®.

Deviation	without expac®	with expac®
Wall thickness	+0.01–0.027 in	+0.008–0.010 in
Weight	+0.007–0.028 lb/ft	+0.006–0.007 lb/ft

The expac® reduces pulsations and material gauge variations, enabling the nominal thickness to be more closely matched. A conservative estimate in this case would be a material saving of 2.0%.

Assuming an extruder throughput rate of 860 lb/hr (equivalent to a size EX 56 pump) and a market price of \$0.90 per lb of PE, the material saving per hour would be:

$$860 \text{ lb/hr} \times 0.02 \times \$0.90 = \$15.48/\text{hr}$$

Assuming three shifts operating 350 operating days per year, the total savings is calculated as follows:
 $\$15.48/\text{hr} \times 24 \text{ hr/day} \times 350 \text{ days} = \$130,032$

Assuming a selling price for an expac® 56 system with a pump, controller, drive, sensors, and universal drive shaft of \$40,000.

The payback on your investment is 16 weeks.



1996 Maag Pump Systems builds the viscorex® 44 ", still the world's largest gear pump for discharging polymers

- 1908 First studies of gears and gear profiles by Max Maag (1883–1960)**
- 1913 Founding and construction of Max Maag gear plant in Zurich, Switzerland**
- 1928 First gear pumps manufactured**
- 1957 Construction of the pump plant near Zurich**
- 1991 Division of Maag Zahnräder AG, formation of Maag Pump Systems AG, Zurich**
- 1996 Certification to ISO 9001 Quality Assurance System**
- 1997 Integration into Textron Inc.**
- 1999 Acquisition of the Fluid Handling Division of LCI**
- 2000 Acquisition of EFC Filtration Systems Inc.**
- 2001 Acquisition of Wil-Man Polymer Filtration GmbH**
- 2004 Maag Pump Systems Textron AG relocates from Zurich to Oberglatt, Switzerland**

An Early Pioneer. Max Maag, who founded the subsequent Maag gear plant, saw the potential of gear wheels from the outset. Besides his engineering company he established a manufacturing plant for gear wheels, and in 1928 he delivered his first gear pump. Since then, his company consistently expanded and fabricated innumerable gear pumps that have been and are still being used successfully – from the smallest pump in the low-pressure range to huge units that can move up to 70 tons of polymer per hour. No other pump company in the world can lay claim to such an accomplished history or record of experience.

Global support. A worldwide service network of knowledgeable technicians are available on a 24/7 basis. These specialists understand process and machine technology, rheology, and materials handling, which enables them to analyze complex conveying problems and find technical solutions. This, coupled with locally stored spare parts, guarantees easy access and fast availability. Installation, commissioning, maintenance, and service activities are handled by our factory specialists as well.

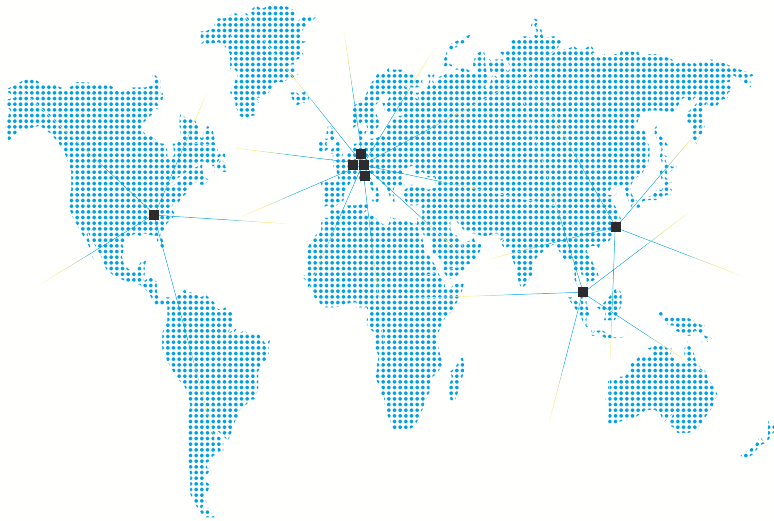

Maag Pump Systems offers you more:

- Worldwide service network of factory direct personnel, agents, and OEMs
- Qualified technicians for installation, commissioning, maintenance and repairs
- Experienced sales personnel, who can assist with your technical issues at any time
- Certified Quality Management to ISO 9001
- Internal and external training programs
- Direct assistance with answers to problems
- Customized viscosity measurements, flow simulations, and application oversight by experienced application engineers

Maag Pump Systems also supplies the chemical and the polymer industry with quality gear pumps, filtering systems, and other accessory components.

Gear pumps for chemical and industrial processes – leaders in demanding applications

Any company that has made innovation a tradition is the right partner for meeting the challenging conditions of your chemical and industrial applications. Gear pumps made from modular components combine strong performance with attractive prices and short lead times. Whatever your requirements, when it comes to pressure, temperature, or viscosity, Maag Pump Systems has the right gear pump for you.

Gear pumps and filter systems for the polymer industry – leaders in reliability.

Maag Pump Systems is the polymer industry leading manufacturer of gear pumps and filter systems. The continuously improved products are based on long-standing expertise, close collaboration with our customers, and compliance with appropriate safety and quality standards.

Switzerland

Maag Pump Systems Textron AG
Aspstrasse 12
8154 Oberglatt
Schweiz
Phone +41 44 278 82 00
Fax +41 44 278 82 01
welcome@maag.textron.com
www.maag.com

USA

Maag Pump Systems Textron Inc.
2915 Whitehall Park Drive
Charlotte, NC 28273
USA
Phone +1 704 716 9000
Fax +1 704 716 9001
MaagAmericas@maag.textron.com
www.maag.com

Germany

Maag Pump Systems Textron GmbH
Ludwig-Erhard-Strasse 10
34131 Kassel
Deutschland
Phone +49 561 31001 0
Fax +49 561 31001 20
MaagGermany@maag.textron.com
www.maag.com

Italy

Maag Textron Italia S.r.l.
Viale Romagna 7
20089 Rozzano (MI)
Italia
Phone +39 02 575 932 1
Fax +39 02 575 932 32
MaagItaly@maag.textron.com
www.maag.com

Singapore

Maag Pump Systems Textron Pte. Ltd.
25 International Business Park
No. 03-22/23 German Center
609916 Singapore
Phone +65 65 62 87 20
Fax +65 65 62 87 29
MaagSingapore@maag.textron.com
www.maag.com

France

Maag Pump Systems Textron SARL
111, Rue du 1er Mars 1943
69100 Villeurbanne
France
Phone +33 4 72 68 67 30
Fax +33 4 72 68 67 31
MaagFrance@maag.textron.com
www.maag.com

China

Maag Pump Systems Textron Shanghai
Room 601 Lippo Plaza
No.222 Huai Hai Zhong Road
200021 Shanghai, China
Phone +86 21 5396 6555
Fax +86 21 5396 6913
MaagChina@maag.textron.com
www.maag.com

A Textron Company

